

Trauma Stretcher

REF Model 1037

stryker[®]

Maintenance Manual



For parts or technical assistance:
USA: 1-800-327-0770



Table of Contents

Symbols and Definitions	6
Symbols	6
Warning/Caution/Note Definition	6
Introduction	7
Product Description	7
Intended Use of Product.	7
Specifications	7
Contact Information	8
Serial Number Location	8
Summary of Safety Precautions	9
Setup Procedures.	11
Cleaning.	12
Stretcher Cleaning	12
Mattress Cleaning	13
Preventative Maintenance	15
Quick Reference Replacement Parts List	16
Service Information.	17
Caster Assembly Replacement.	17
Brake Swivel Lock Ring Replacement.	18
Brake Timing Link Replacement, Head End or Foot End	19
Brake Cam Assembly Replacement	20
Brake Rod Replacement - Fifth Wheel Only	21
Brake Rod Replacement - Big Wheel Only	22
Fifth Wheel Assembly Replacement	23
Jack Replacement, Head End - Fifth Wheel Only	24
Jack Replacement, Head End - Big Wheel Only	25
Jack Replacement, Foot End - Fifth Wheel Only	26
Jack Removal, Foot End - Big Wheel Base with Three-Sided Controls.	27
Release Pedal (Side) Adjustment	28
Litter Top Removal.	29
Transfer Board Counterbalance Adjustment	30
Fold Down Siderail Latch Adjustment	30
Release Pedal Replacement, Foot End.	31
Release Pedal Rod Removal, Foot End.	31
Big Wheel Removal (Non Four-Sided Brakes)	32
Big Wheel Removal (Four-Sided Brakes).	32
Big Wheel Dampener Replacement	33
Pneumatic Fowler Adjustment	34
Removal of Excess Air from the Hydraulic System	35
Fifth Wheel Standard Brake Assembly.	36
Fifth Wheel Brake Rod Assembly	39
Fifth Wheel Drive Link Assembly - 0853-206-135.	40
Fifth Wheel Side Control Brake Assembly	41
Fifth Wheel Brake Rod/Side Control Assembly.	45

Table of Contents





Fifth Wheel Side Control Brake Assembly	46
Bumper Color Options - Individual or Set of Four.	47
8" Caster with Full Cover Assembly - 0853-503-020	48
Retractable Fifth Wheel Assembly.	49
Fifth Wheel Assembly - 1105-006-130	50
Fifth Wheel Dual Sided Hydraulics Assembly.	52
Lowering Pedal Assembly - 1105-004-201	54
Pump Pedal Assembly, Head End - 1105-005-285	55
Constant Descent Jack.	56
Big Wheel Standard Brake Assembly	60
Big Wheel Cam Bracket Assembly - 1115-006-201.	63
Big Wheel Carriage Assembly.	65
Big Wheel Dual Sided Hydraulics Assembly.	66
Pump Pedal Assembly, Head End - 1115-005-285	69
Lowering Pedal Assembly - 1115-004-201	70
Big Wheel Four-Sided Control Base Assembly.	71
Big Wheel Side Control Carriage Assembly	74
Big Wheel Side Control Linkage Assembly - 1040-125-010.	76
Base Labeling Assembly, Standard Brakes	77
Base Labeling Assembly, Four-Sided Brakes	78
Base Labeling Assembly - Big Wheel Base	79
Litter Assembly.	80
Litter Support Assembly, Head End - 1037-024-003.	85
Litter Support Assembly, Foot End - 1037-024-002	86
Siderail, Left - 1010-026-017.	87
Siderail, Right - 1010-026-019.	88
Pneumatic Fowler to Litter Assembly.	89
Pneumatic Fowler Assembly	90
Transfer Board Assembly	91
Transfer Board Assembly, Left - 1037-024-010.	92
Transfer Board Assembly, Right - 1037-024-011.	93
Arm Board Support Assembly - 1010-024-030	94
X-Ray Tray Assembly, Right Side Load - 1037-022-000	95
X-Ray Tray Assembly, Left Side Load - 1037-021-000	97
X-Ray Grid Holder Assembly - 1020-027-000.	99
Optional X-Ray Centering Guide - 1020-020-000.	100
Optional Push Handles, Head End - 1037-151-000	101
Push Handle Assembly - 1211-351-010	102
Optional Push Handles, Foot End - 1037-051-000	103
Push Handle Assembly With I.V., Head End - 1037-151-004	104
Push Handle Assembly Without I.V., Head End - 1020-151-001	105
Cover Assembly with Pop Up Push Handles, Head End - 1037-151-005.	106

Table of Contents

Optional Accessories	108
C-Spine Cassette Holder Assembly - 1020-070-000	109
C-Spine Storage Bracket Assembly - 1020-070-019	110
C-Spine Support Pole Assembly - 1010-070-010	111
Defibrillator Tray Assembly - 1105-045-200	112
Defibrillator Tray/Foot Extender/Foot Board - 1105-045-400	113
Footboard/Chartholder Assembly - 1105-045-500	114
Fowler X-Ray Cassette Assembly - 1020-023-000	115
Heel Stirrups - 1020-055-000	116
I.V. Caddy - 0785-155-000	117
Removable I.V. Pole - 0390-025-000	118
Tethered I.V. Pole Assembly - 1001-087-018	119
Two-Stage I.V. Pole Assembly, Head End 1010-081-000	120
Three-Stage I.V. Pole Assembly, Head End 1020-061-000/	121
Three-Stage I.V. Pole Assembly, Foot End 1020-062-000	121
Two-Stage I.V. Pole Assembly, Foot End 1010-080-000	122
Upright Oxygen Bottle Holder - 1115-130-000	123
Serving Tray - 1105-045-700	124
Foot Board/Serving Tray Holder - 1105-045-800	125
Mattresses and Siderail Pads	126
Warranty	127
Limited Warranty	127
To Obtain Parts and Service	127
Service Contract Coverage	127
Service Contract Programs	128
Return Authorization.	128
Damaged Merchandise	128
International Warranty Clause.	128

Symbols and Definitions

SYMBOLS

	Warning/Caution: Consult accompanying documentation
	Safe Working Load indicates the sum of the patient, mattress, and accessory weight
	Do not store oxygen bottle
	Do not push/pull
	Manufacturer

WARNING/CAUTION/NOTE DEFINITION

The words **WARNING**, **CAUTION** and **NOTE** carry special meanings and should be carefully reviewed.

WARNING

Alerts the reader about a situation which, if not avoided, could result in death or serious injury. It may also describe potential serious adverse reactions and safety hazards.

CAUTION

Alerts the reader of a potentially hazardous situation which, if not avoided, may result in minor or moderate injury to the user or patient or damage to the equipment or other property. This includes special care necessary for the safe and effective use of the device and the care necessary to avoid damage to a device that may occur as a result of use or misuse.

NOTE

Provides special information to make maintenance easier or important instructions clearer.

Introduction

This manual is designed to assist you with the operation of Stryker Model 1037 Trauma Stretcher. Read this manual thoroughly before using the equipment or beginning maintenance on it. To ensure safe operation of this equipment, it is recommended that methods and procedures be established for educating and training staff on the safe operation of this stretcher.

PRODUCT DESCRIPTION

The Stryker Model 1037 Trauma Stretcher is a general purpose patient transport and treatment stretcher.

INTENDED USE OF PRODUCT

The Stryker Medical Trauma Stretcher is a non-powered, wheeled device which consists of a platform mounted on a wheeled frame that is designed to support patients in a horizontal position. The device has siderails and has the option available to support the temporary or permanent placement of I.V. poles. A stretcher provides the operator a method of transporting patients within a healthcare facility. Some stretchers may also be used for minor procedures and short-term stay (treatment and recovery).

SPECIFICATIONS

	Safe Working Load Note: Safe Working Load indicates the sum of the patient, mattress, and accessory weight.	500 lb.	226.8 kg.
Overall Stretcher Length	83"	210.8 cm	
Minimum / Maximum Stretcher Height	24.5" / 37.5"	62.2 cm / 95.3 cm	
Fowler Angle	0° to 90°		
Trendelenburg / Reverse Trendelenburg	+18°/-18°		
Minimum Under-Stretcher Clearance	6" nominal	15 cm	
	1.75" under the hydraulic cylinders and fifth wheel	4.5 cm	

Stryker reserves the right to change specifications without notice.

Introduction

CONTACT INFORMATION

Contact Stryker Customer Service or Technical Support at: (800) 327-0770 or (269) 324-6500.

Stryker Medical
3800 E. Centre Avenue
Portage, MI 49002
USA

Please have the serial number (A) of your Stryker product available when calling Stryker Customer Service or Technical Support. Include the serial number in all written communication.

SERIAL NUMBER LOCATION

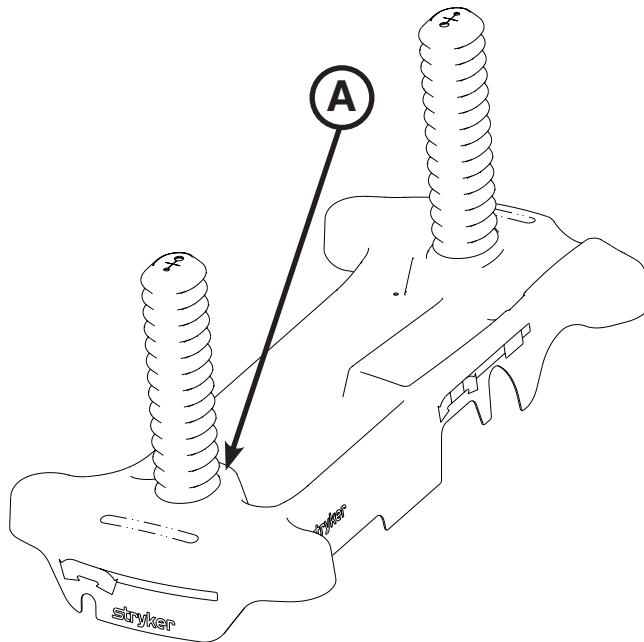

Summary of Safety Precautions

Carefully read and strictly follow the warnings and cautions listed on this page.

Service only by qualified personnel. See the maintenance manual for additional information.

WARNING

- Always apply the brakes when a patient is getting on or off the stretcher. Push on the stretcher to ensure that the brakes are securely locked. Always engage the brakes unless the stretcher is being moved. Injury could result if the stretcher moves while a patient is getting on or off the stretcher.
 - Patients should be discouraged from sitting directly on the ends of the stretcher. Excessive weight could cause the litter surface to tip up, possibly causing patient injury.
 - Leave the stretcher height in the lowest position when the patient is left unattended. Leaving the stretcher height in a raised position could increase the chance of patient falls and injury.
 - Make sure that the brakes are completely released before attempting to move the unit. Attempting to move the unit with the brakes engaged could result in injury to the user and/or patient.
 - After raising the siderails, pull firmly on the siderail to ensure that it is securely locked into the fully raised position. Siderails are not intended to serve as a patient restraint device to keep patients from exiting the unit. Siderails are intended to keep a patient from inadvertently rolling off the unit. It is the responsibility of the attending medical personnel to determine the degree of restraint necessary to ensure that a patient will remain in place. Failure to utilize the siderails properly could result in patient injury.
 - When lowering the siderail to the collapsed position, keep extremities of patients and staff away from the siderail spindles or injury could occur.
 - During patient transfer, keep patient and operator extremities away from collapsed siderails or injury could occur.
 - When using the transfer board to transfer a patient from one patient support platform (for example, bed, stretcher, gurney, operating table) to another, always lock the brakes on both patient support platforms. Make sure that the transfer board is placed securely on the surface of the patient support platforms. The patient support platforms and surfaces must be at the same height before the patient is transferred.
 - Operation of the pneumatic fowler is a manual procedure. Use caution when raising the fowler while a patient is on the stretcher. Use proper lifting techniques and get additional assistance, if necessary. Failure to use proper lifting techniques could cause injury to the operator.
 - Keep hands/fingers clear of the area around the fowler release handle and the fowler frame when lowering the fowler. Injury could result if care is not taken when lowering the fowler.
 - If the stretcher is equipped with the optional foot end push handles, use caution while the foot extension/defibrillator tray is installed to avoid pinching your fingers.
 - To avoid the risk of injury to the patient or user or damage to the I.V. pole while transporting the stretcher, make sure that the I.V. caddy is securely tightened on the I.V. pole.
-

CAUTION

- Do not modify this stretcher. Modifying the unit can cause unpredictable operation resulting in injury to the patient or operator. Modifying the unit will also void its warranty.
 - To avoid damage, remove any equipment that may be in the way before raising or lowering the litter height.
 - Do not raise the unit (hydraulics on base) with a patient lift under the stretcher.
 - Do not engage the steer pedal when the Big Wheel is resting on a threshold or other raised area. The force required to engage the Big Wheel will be higher than normal, possibly causing damage.
 - To avoid injury or damage to the equipment, do not allow the siderail to lower on its own.
-

[Return To Table of Contents](#)

Summary of Safety Precautions

CAUTION (CONTINUED)

- The push handles were designed for use while transporting the stretcher. Avoid using other parts of the stretcher as push/pull devices because damage could occur.
- When the transfer board is being used to transfer a patient, the support post must be in the stored (down) position. Damage to the support post will occur if it is pushed up against a stretcher, table, etc.
- The weight capacity of the base hood is 60 lb. Do not sit or stand on the base hood. Injury or damage to the equipment could occur.
- Do not step on the base hood.
- Do not use the cutout for the oxygen bottle holder on the base hood for the storage of oxygen bottles or patient belongings.
- To avoid damage, do not put items weighing more than 30 lb. on the defibrillator tray.
- Do not use the defibrillator tray as a push/pull device because equipment damage could occur.
- If the stretcher is equipped with the optional foot end I.V. pole, the I.V. pole must be in the raised position when the foot extension/defibrillator tray is installed. If the I.V. pole is not raised, the foot extension will not function properly and injury could occur.
- To avoid damage, do not put items weighing more than 30 lb. on the defibrillator tray/foot extender.
- Do not use the defibrillator tray/foot extender as a push/pull device because equipment damage could occur.
- Do not use the footboard/chart holder as a push/pull device because equipment damage could occur.
- Always store the I.V. caddy when not in use to avoid damaging it when the unit is moved.
- To avoid damage, do not put items weighing more than 30 lb. on the serving tray.
- Do not use the serving tray as a push/pull device because equipment damage could occur.
- To avoid damage, the weight of the I.V. bags should not exceed 40 lb.
- To avoid damage while transporting the stretcher, verify that the I.V. pole is at a low enough height to allow it to safely pass through door openings and under light fixtures.
- Do not use the I.V. pole as a push/pull device because equipment damage could occur.
- To avoid damage, the weight of the I.V. bags should not exceed 12 lb. while the weight of any one item attached to each stage of the three-stage permanently attached I.V. pole should not exceed 9.3 lb.
- To avoid damage, do not put items weighing more than 40 lb. in the upright oxygen bottle holder.
- Do not use the upright oxygen bottle holder as a push/pull device because equipment damage could occur.
- Before returning the unit to service after cleaning, ensure that the unit is functioning properly by verifying that all labels are intact, raise/lower the stretcher height, brake/steer pedal locks properly in both positions, latch/unlatch the siderails, raise/lower the fowler and gatch, and check all components for proper lubrication.
- Some cleaning products are corrosive in nature and may cause damage to the product if used improperly. If the products suggested above are used to clean Stryker patient handling equipment, measures must be taken to ensure that the stretcher is wiped with a damp cloth soaked in clean water and thoroughly dried following cleaning. Failure to properly rinse and dry the stretcher will leave a corrosive residue on the surface of the stretcher, possibly causing premature corrosion of critical components. Failure to follow the above directions when using these types of cleaners may void this product's warranty.

NOTE

- Clean the base hood storage area regularly.
- The bottom of the brake pads should be cleaned regularly to prevent wax or floor remnant buildup.

Setup Procedures

Make sure that the unit is working properly before it is put into service. The following list will ensure that each part of the unit is checked.

1. Fully depress the brake pedal of the stretcher to set the four wheel brakes and verify that all four casters are locked.
2. Raise and lower the hydraulic lift system.
3. Raise the unit completely and activate the Trendelenburg function. Ensure that the head end lowers to the lowest position.
4. Raise the unit completely and activate the reverse Trendelenburg function. Ensure that the foot end lowers to the lowest position.
5. Activate the fifth wheel to ensure that it is operating properly or activate the Big Wheel to ensure that it is operating properly.
6. Ensure that the siderails raise and lower smoothly and lock securely when fully raised.
7. Raise and lower the fowler (head end).

 **CAUTION**

Do not modify this stretcher. Modifying the unit can cause unpredictable operation resulting in injury to the patient or operator. Modifying the unit will also void its warranty.

Cleaning

STRETCHER CLEANING

These instructions are intended to provide recommended cleaning methods for the Stryker Model 1037 Trauma Stretcher.

RECOMMENDED CLEANING METHOD

Note: Follow the cleaning solution manufacturer's dilution recommendations exactly.

- Remove the mattress prior to washing the unit; do not wash the mattress with the stretcher.
- Wipe the unit with cleaning solution and water per manufacturer's recommended dilution.
- Dry thoroughly. Do not replace the mattress on the stretcher until the unit is completely dry.



CAUTION

Before returning the unit to service after cleaning, ensure that the unit is functioning properly by verifying that all labels are intact, raise/lower the stretcher height, brake/steer pedal locks properly in both positions, latch/unlatch the siderails, raise/lower the fowler and gatch, and check all components for proper lubrication.

DO NOT STEAM CLEAN, PRESSURE WASH, HOSE OFF OR ULTRASONICALLY CLEAN THE STRETCHER.

Using these methods of cleaning are not recommended and may void this product's warranty.

RECOMMENDED CLEANERS

Suggested cleaners for stretcher surfaces:

Quaternary Cleaners (active ingredient - ammonium chloride).

Phenolic Cleaners (active ingredient - o-phenylphenol).

Chlorinated Bleach Solution (5.25% - less than 1 part bleach to 100 parts water).

Avoid over saturation and ensure the product does not stay wet longer than the chemical manufacturer's guidelines for proper disinfecting.



CAUTION

Some cleaning products are corrosive in nature and may cause damage to the product if used improperly. If the products suggested above are used to clean Stryker patient handling equipment, measures must be taken to ensure that the stretcher is wiped with a damp cloth soaked in clean water and thoroughly dried following cleaning. Failure to properly rinse and dry the stretcher will leave a corrosive residue on the surface of the stretcher, possibly causing premature corrosion of critical components. Failure to follow the above directions when using these types of cleaners may void this product's warranty.

Cleaning

MATTRESS CLEANING

These instructions are intended to provide recommended cleaning methods for stretcher mattresses.

RECOMMENDED CLEANING METHOD

- Hand-wash all surfaces of the mattress with warm water and mild detergent cleaner.
- Dry thoroughly.
- Apply disinfectant solution either by spray, solution or pre-impregnated wipes (do not soak mattress).
- Clean per hospital protocol for mattresses.
- Wipe up excess disinfectant.
- Rinse with clean water.
- Allow surface to dry.

RECOMMENDED DISINFECTANTS

IMPORTANT: DILUTE ALL DISINFECTANTS IN ACCORDANCE WITH MANUFACTURER'S DIRECTIONS

When used in concentrations recommended by the manufacturer, diluted bleach, diluted phenolic, or diluted quaternary germicidal disinfectants are recommended. Chlorine Bleach, typically 5.25% Sodium Hypochlorite, should be used at a dilution ratio of 1 part bleach to 10 parts water.

RINSE OFF CORROSIVE CLEANERS

These products are NOT considered mild detergents. They are corrosive in nature and may cause damage to your stretcher mattress if used improperly. Mattresses must be rinsed with clean water and dried thoroughly after using corrosives such as quaternary, phenolic, or chlorine bleach. Failure to properly rinse and dry the mattress leaves a corrosive residue on the surface, likely causing premature corrosion.

Iodophor type disinfectants are not recommended for use because staining may result.

The following table lists the recommended cleaner types for each mattress cover material (see definitions below):

	Vinyl Mattress Cover	Polyurethane Mattress Cover
Recommended	Phenolics	Quaternary, Quat/Isopropyl
Acceptable	Quaternary, Chlorine Bleach (1:10)	Chlorine Bleach (1:10)
Not Recommended	Quat/Isopropyl	Phenolics

Quaternary Cleaners: identified by ingredients containing the phrase "...yl ammonium chloride"

Quat/Isopropyl Cleaners: identified by a quaternary ingredient above plus isopropyl alcohol

Phenolic Cleaners: identified by ingredients containing the suffix "-phenol"

Chlorine Bleach: known generically as "Sodium Hypochlorite"

Cleaning

MATTRESS CLEANING (CONTINUED)

SPECIAL INSTRUCTIONS

Velcro	To clean and disinfect, saturate with disinfectant, rinse with water, and allow it to evaporate.
Soils or Stains	Use neutral soaps and warm water. Do not use harsh cleansers, solvents or abrasive cleaners.
Hard-To-Clean Spots	Use standard household/vinyl cleansers and a soft bristle brush on troublesome spots or stains. Pre-soak heavy, dried-on soil.
Laundering	Laundering is NOT RECOMMENDED. Laundering may substantially decrease the useful life of the mattress.

DO NOT STEAM CLEAN, PRESSURE WASH, HOSE OFF OR ULTRASONICALLY CLEAN MATTRESSES.

Using these methods of cleaning are not recommended and may void this product's warranty.

REMOVAL OF IODINE STAINS

1. Make a solution of 1–2 tablespoons Sodium Thiosulfate in a pint of warm water and use it to wipe the stained area. Clean the stain as soon as possible after it occurs. If stains are not immediately removed, allow solution to soak or stand on the surface before wiping.
2. Rinse surfaces which have been exposed to the solution with clear water before returning mattress to service.

Note: Failure to follow the above directions when using these types of cleaners may void this product's warranty.

Preventative Maintenance

At a minimum, preventative maintenance should be performed annually. A preventative maintenance program should be established for all Stryker Medical equipment. Preventative maintenance may need to be performed more frequently based on the usage level of the product.

- _____ All fasteners secure
- _____ Siderails move and latch properly
- _____ Engage brake pedal and push on the stretcher to ensure all casters lock securely
- _____ Steer function working properly
- _____ All casters secure and swivel properly
- _____ Inspect each caster and remove any wax or debris which may have collected on the caster or braking mechanism
- _____ Body restraints working properly
- _____ I.V. pole intact and operating properly
- _____ Oxygen bottle holder intact and operating properly
- _____ Fowler operating and latching properly
- _____ Trendelenburg/reverse Trendelenburg operating properly
- _____ No rips or cracks in mattress cover
- _____ Transfer boards intact and operating properly
- _____ Ground chain intact
- _____ No leaks at hydraulic connections
- _____ Hydraulic jacks hold properly
- _____ Hydraulic drop rate set properly
- _____ Hydraulic oil level sufficient
- _____ Lubricate where required
- _____ X-ray tray slide tracks cleaned of dust and debris
- _____ Accessories and mounting hardware in good condition and working properly

Product Serial Number:		

Completed by: _____ Date: _____

Quick Reference Replacement Parts List

The parts and accessories listed on this page are all currently available for purchase. Some of the parts identified on the assembly drawing parts in this manual may not be individually available for purchase. Please call Stryker Customer Service USA at 1-800-327-0770 for availability and pricing.

Part Name	Part Number
Big Wheel Assembly	1115-015-073
Big Wheel Timing Cam and Link Assembly	1040-003-035
Brake Cam and Link Assembly (Fifth Wheel)	0853-003-035
Caster Assembly	0853-503-020
Fifth Wheel Assembly	1105-006-130
Fowler Gas Cylinder	1010-031-078
Hydraulic Jack, Constant	0753-002-101
I.V. Pole, Standard, Removable	0390-025-000
Paint, Touch-Up, Gloss Black, Bottle with Brush	7000-001-322
Paint, Touch-Up, Gloss Black, Spray Can	7000-001-319
Paint, Touch-Up, White, Bottle with Brush	7000-001-147
Paint, Touch-Up, White, Spray Can	7000-001-148
Restraint Strap Package	0785-045-010
Restraint Strap, Ankle	0785-045-020
Restraint Strap, Body	0785-045-015
Restraint Strap, Wrist	0946-044-000
Siderail Pads	1010-052-000

Service Information

CASTER ASSEMBLY REPLACEMENT

Tools Required:

- 1/2" Socket
- 3/8" Drive Ratchet
- Needle Nose Pliers
- Bungee Cords
- Small Bottle Jack
- 3/8" Drive Torque Wrench (ft-lb)

Procedure:

1. Pump the stretcher all the way up.
2. Raise both siderails to the up and latched position.
3. Using bungee cords, support the raised base hood.
4. Put the base brake/steer pedal in the neutral position.
5. Using a 1/2" socket, remove the two flange nuts (one on each side) that secure the timing link to the casters.
6. Using needle nose pliers, remove the rue clip and then the clevis pin from the brake rod activator.
7. Apply the brakes by moving the brake/steer pedal to the brake position.
8. Remove the brake timing link assembly by equally pulling outward on the timing link assembly. Save the brake timing link for reinstallation.
9. Using a small bottle jack, raise the stretcher up until the caster falls out of the frame socket. Discard the caster.
10. Install the new caster assembly by carefully and slowly lowering the jack down until the caster is secured in the base frame, and then remove the jack.

Note: Make sure that the arrow located at the top of the caster assembly fork stem points toward the foot end of the unit. If the arrow does not point toward the foot end, damage could occur to the caster assembly.

11. Reverse steps to reinstall. Torque the two flange nuts that secure the timing link assembly to the casters to 80 ± 20 ft-lb.

Note: When installing the new brake timing link assembly be sure to reinstall the bushing which may have fallen off during the removal of the old brake timing link assembly.

12. Verify proper operation of the unit before returning it to service.

Service Information

BRAKE SWIVEL LOCK RING REPLACEMENT

Tools Required:

- 1/2" Socket
- 5/16" Socket
- 3/8" Drive Ratchet
- 1/4" Ratchet
- Needle Nose Pliers
- Bungee Cords
- Small Bottle Jack
- 3/8" Drive Torque Wrench (ft-lb)

Procedure:

1. Pump the stretcher all the way up.
2. Raise both siderails to the up and latched position.
3. Using bungee cords, support the raised base hood.
4. Put the base brake/steer pedal in the neutral position.
5. Using a 1/2" socket, remove the two flange nuts (one on each side) that secure the timing link to the casters.
6. Using needle nose pliers, remove the rue clip, and then the clevis pin from the brake rod activator.
7. Apply the brakes by moving the brake/steer pedal to the brake position.
8. Remove the brake timing link assembly by equally pulling outward on the timing link assembly. Save the brake timing link for reinstallation.
9. Using a small bottle jack, raise the stretcher up until the caster falls out of the frame socket. Discard the caster.
10. Using a 5/16" socket, remove the two bolts that secure the brake swivel lock ring to the base frame and remove. Discard the brake swivel lock ring.
11. Using a 5/16" socket, install the new brake swivel lock ring.

Note: The brake swivel lock ring has two dowels that mate to the base frame when installing.

12. Install the new caster assembly by carefully and slowly lowering the jack down until the caster is secured in the base frame, and then remove the jack.

Note: Make sure that the arrow located at the top of the caster assembly fork stem points toward the foot end of the unit. If the arrow does not point toward the foot end, damage could occur to the caster assembly.

13. Reverse steps to reinstall. Torque the two flange nuts that secure the timing link assembly to the casters to 80 ± 20 ft-lb. Torque the two bolts that secure the brake swivel lock ring to the base frame to 50 ± 4 ft-lb.

Note: When installing the new brake timing link assembly be sure to reinstall the bushing which may have fallen off during the removal of the old brake timing link assembly.

14. Verify proper operation of the unit before returning it to service.

Service Information

BRAKE TIMING LINK REPLACEMENT, HEAD END OR FOOT END

Tools Required:

- 1/2" Socket
- 3/8" Drive Ratchet
- Needle Nose Pliers
- Bungee Cords
- 3/8" Drive Torque Wrench (ft-lb)

Procedure:

1. Pump the stretcher all the way up.
2. Raise both siderails to the up and latched position.
3. Using bungee cords, support the raised base hood.
4. Put the base brake/steer pedal in the neutral position.
5. Using a 1/2" socket, remove the two flange nuts (one on each side) that secure the timing link assembly to the casters.
6. Using needle nose pliers, remove the rue clip and then clevis pin from the brake rod activator.
7. Apply the brakes by moving the brake/steer pedal to the brake position.
8. Remove the brake timing link assembly by equally pulling outward on the timing link assembly. Discard the brake timing link.
9. Reverse steps to reinstall. Torque the two flange nuts that secure the timing link assembly to the casters to 80 ± 20 ft-lb.

Note: When installing the new brake timing link assembly be sure to reinstall the bushing which may have fallen off during the removal of the old brake timing link assembly.

10. Verify proper operation of the unit before returning it to service.

Service Information

BRAKE CAM ASSEMBLY REPLACEMENT

Tools Required:

- Needle Nose Pliers
- Bungee Cords

Procedure:

1. Pump the stretcher all the way up.
2. Raise both siderails to the up and latched position.
3. Using bungee cords, support the raised base hood.
4. Put the base brake/steer pedal in the neutral position.
5. Using needle nose pliers, remove the rue clip and clevis pin that secure the brake cam assembly to the brake rod. Save all parts for reinstallation.
6. Using needle nose pliers, remove the rue clip and washer from the top bearing pivot support. Save all parts for reinstallation.
7. Using needle nose pliers, remove the rue clip and plastic washer from the bottom support. Save the rue clip for reinstallation.
8. Raise the brake cam link off of the brake rod actuator and slowly pull outward on the brake cam assembly. Discard the brake cam assembly.
9. Reverse steps to reinstall.

Note: When installing the new brake cam assembly, install the bottom slightly first and then push downward and inward to install under the top bearing.

10. Verify proper operation of the unit before returning it to service.

Service Information

BRAKE ROD REPLACEMENT - FIFTH WHEEL ONLY

Tools Required:

- Hammer
- 7/32" #7 Roll Pin Punch
- Needle Nose Pliers
- Bungee Cords

Procedure:

1. Pump the stretcher all the way up.
2. Raise both siderails to the up and latched position.
3. Using bungee cords, support the raised base hood.
4. Put the brake/steer pedal into the steer position.
5. Using a hammer and a 7/32" roll pin punch, remove the eight roll pins from pedal to pedal on the brake rod.
6. Using needle nose pliers, remove the rue clip and clevis pin that secure the brake link to the brake rod.
7. Using your hands, grasp the brake rod and remove each brake/steer pedal. Save the pedals for reinstallation.
8. Remove the brake rod from the base.
9. Install the new brake rod and then install the roll pin into the head end timing link arm first.
10. Reverse steps to reinstall.
11. Verify proper operation of the unit before returning it to service.

Service Information

BRAKE ROD REPLACEMENT - BIG WHEEL ONLY

Tools Required:

- Hammer
- 7/32" #7 Roll Pin Punch
- Needle Nose Pliers
- Bungee Cords

Procedure:

1. Pump the stretcher all the way up.
2. Raise both siderails to the up and latched position.
3. Using bungee cords, support the raised base hood.
4. Put the brake/steer pedal into the steer position.
5. Using a hammer and a 7/32" roll pin punch, remove the two roll pins from pedal to pedal on the brake rod.
6. Using needle nose pliers, remove the five rue clips and clevis pins from the brake rod. Save all parts for reinstallation.

Note: If the unit has four-sided brakes, there will be a sixth rue clip and clevis pin to remove.

7. Using a 5/32" Allen wrench, loosen the set screw on the head end brake rod stop collar.
8. Remove the brake rod from the base.
9. Reverse steps to install the new brake/steer pedal assembly.
10. Verify proper operation of the unit before returning it to service.

Service Information

FIFTH WHEEL ASSEMBLY REPLACEMENT

Tools Required:

- 1/2" Socket
- 3/8" Drive Ratchet
- Needle Nose Pliers
- Bungee Cords
- 3/8" Drive Torque Wrench (ft-lb)

Procedure:

1. Pump the stretcher all the way up.
2. Raise both siderails to the up and latched position.
3. Using bungee cords, support the raised base hood.
4. Using a 1/2" socket, remove the bolt that holds the fifth wheel cam drive link to the cam.
5. Using a 1/2" socket, remove the two bolts that secure the fifth wheel assembly to the base frame.
6. Using needle nose pliers, remove the pump pedal return spring from the fifth wheel bracket.
7. Using needle nose pliers, remove the foot end jack release rod from the release pedal.
8. Remove the release rod.
9. Working from the patients left side, rotate the fifth wheel assembly counter clockwise while lifting the fifth wheel assembly up and out.
10. Reverse steps to reinstall. Torque all bolts to 13 ± 2 ft-lb.
11. Verify proper operation of the unit before returning it to service.

Service Information

JACK REPLACEMENT, HEAD END - FIFTH WHEEL ONLY

Tools Required:

- 1/2" Socket with Extension
- 3/8" Drive Ratchet
- 3/8" Drive Torque Wrench (ft-lb)

Procedure:

1. Remove the litter from the stretcher. See "Litter Top Removal" on [page 29](#).
2. Using a 1/2" socket with extension and a 3/8" drive ratchet, remove the two hex head screws that hold the jack base to the stretcher base frame. When reinstalling, torque the screws to 11 ± 5 ft-lb.
3. Remove the two hex head screws that hold the jack reservoir clamp to the base frame and remove the clamps.
4. Lift straight up on the pump connecting rod and disconnect the pump piston from the connecting rod. When reinstalling, torque the screws to 13 ± 2 ft-lb.
5. Disconnect the pump pedal swivel from the release pedal mounting plate.
6. Remove the head end release rod from the release valve assembly.
7. Using a 1/2" socket with extension, remove the two hex head screws that hold the jack base to the stretcher base frame. When reinstalling, torque the screws to 13 ± 2 ft-lb.
8. Remove the jack assembly.
9. To reinstall the jack, install the bolts on the jack and reservoir clamp but do not tighten them fully.
10. Reinstall the pump connecting rod and release rod.
11. Depress the pump pedal fully (to the floor). This will properly locate the jack onto the base frame.
12. Tighten the bolts on the jack and reservoir clamp. Torque all bolts to 13 ± 2 ft-lb.
13. With the assistance of another person, reinstall the litter top onto the jack shafts.
14. Torque the hex head screws on the support tube weldments to 11 ± 5 ft-lb.
15. Pump up the litter and apply weight to verify the jacks hold and do not drift.
16. Verify proper operation of the unit before returning it to service.

Note: The jack descent rate is set at the factory and adjustment is not recommended.

Service Information

JACK REPLACEMENT, HEAD END - BIG WHEEL ONLY

Tools Required:

- 1/2" Socket with Extension
- 3/8" Drive Ratchet
- 3/8" Drive Torque Wrench (ft-lb)

Procedure:

1. Remove the litter from the stretcher. See "Litter Top Removal" on [page 29](#).
2. Using a 1/2" socket with extension and a 3/8" drive ratchet, remove the two hex head screws that hold the jack base to the stretcher base frame.
3. Remove the two hex head screws that hold the jack reservoir clamp to the base frame and remove the clamps.
4. Lift straight up on the pump connecting rod and disconnect the pump piston from the connecting rod.
5. Disconnect the release pedal swivel from the release pedal weldment.
6. Remove the head end release rod from the release valve assembly.
7. Using a 1/2" socket with extension, remove the two hex head screws that hold the jack base to the stretcher base frame.
8. Lift out the jack assembly.
9. To reinstall the jack, install the bolts on the jack and reservoir clamp but do not tighten them fully.
10. Reinstall the pump connecting rod and release rod.
11. Depress the pump pedal fully (to the floor). This will properly locate the jack onto the base frame.
12. Tighten the bolts on the jack and reservoir clamp. Torque all bolts to 13 ± 2 ft-lb.
13. Pump up the litter and apply weight to verify the jacks hold and do not drift.

Note: The jack descent rate is set at the factory and adjustment is not recommended.

Service Information

JACK REPLACEMENT, FOOT END - FIFTH WHEEL ONLY

Tools Required:

- 1/2" Socket with Extension
- 3/8" Drive Ratchet
- Pliers
- 3/8" Drive Torque Wrench (ft-lb)

Procedure:

1. Remove the litter from the stretcher. See "Litter Top Removal" on [page 29](#).
2. Lift the base hood off of the base frame.
3. Using a 1/2" socket with extension, remove the two hex washer head screws and washers that connect the pump pedal link to the foot end pump pedal assembly and pump connecting rod.
4. Remove the foot end release rod from the release valve on the jack assembly by disconnecting the release pedal swivel from the pins on the release pedal weldment.
5. Disconnect the jack pump piston from the pump connecting rod.
6. Using a 1/2" socket with extension, remove the two hex washer head screws that hold the reservoir clamp.
7. Remove the jack assembly.
8. To reinstall the jack, install the bolts on the jack and reservoir clamp but do not tighten them fully.
9. Reinstall the pump connecting rod and release rod.
10. Depress the pump pedal fully (to the floor). This will properly locate the jack onto the base frame.
11. Tighten the bolts on the jack and reservoir clamp. Torque all bolts to 13 ± 2 ft-lb.
12. With the assistance of another person, reinstall the litter top onto the jack shafts.
13. Torque the hex head screws on the support tube weldments to 11 ± 5 ft-lb.
14. Pump up the litter and apply weight to verify the jacks hold and do not drift.
15. Verify proper operation of the unit before returning it to service.

Note: The jack descent rate is set at the factory and adjustment is not recommended.

Service Information

JACK REMOVAL, FOOT END - BIG WHEEL BASE WITH THREE-SIDED CONTROLS

Tools Required:

- 1/2" Socket with Extension
- 3/8" Drive Ratchet
- 3/8" Drive Torque Wrench (ft-lb)

Procedure:

1. Remove the litter from the stretcher. See "Litter Top Removal" on [page 29](#).
1. Lift the base hood off of the base frame.
2. Remove the hair pin cotter and washer that connect the Big Wheel side control linkage toggle pivot plates to the Big Wheel side control carriage weldment.
3. Remove the rue ring cotter and clevis pin that connect the Big Wheel side control rod end link to the yolk weldment on the end control brake rod.
4. Remove the Big Wheel carriage assembly.
5. Remove the two hex washer head screws and washers that connect the pump pedal link to the foot end pump pedal assembly and pump connecting rod.
6. Remove the foot end pump pedal return spring.
7. Remove the cotter pin from the center of the foot end pump pedal assembly and slide out the pivot pin.
8. Slide the foot end pump pedal assembly up and over the foot end mounting bracket.
9. Remove the four hex washer head screws that fasten the foot end mounting bracket to the base frame and set the bracket aside.
10. Remove the foot end release rod from the release valve on the jack assembly by dislodging the release pedal swivel from the pins on the release pedal weldment.
11. Dislodge the jack pump piston from the pump connecting rod.
12. Remove the two hex washer head screws that hold the reservoir clamp in place.
13. Remove the jack assembly.
14. Reverse steps to reinstall. Torque all bolts to 13 ± 2 ft-lb.
15. Verify proper operation of the unit before returning it to service.

Note: The jack descent rate is set at the factory and adjustment is not recommended.

Service Information

RELEASE PEDAL (SIDE) ADJUSTMENT

Tools Required:

- None

Procedure:

1. Manually disengage the release pedal swivel from the release pedal assembly.
2. To increase the release rod engagement with the release valve, turn the release pedal swivel clockwise on the threaded release rod.
3. To decrease the release rod engagement with the release valve, turn the release pedal swivel counterclockwise on the threaded release rod.

Note: If the pedal swivel assembly is threaded too far onto the release rod, the release valve will be partially activated and the jack will drift.

Service Information

LITTER TOP REMOVAL

Tools Required:

- 1/2" Socket with Extension
- 3/8" Drive Ratchet
- Standard Screwdriver
- 3/8" Drive Torque Wrench (ft-lb)
- 7/16"-20 Bolt

Procedure:

1. Using the foot pedal, pump the litter top all the way up.
2. Remove the stretcher mattress.
3. Using a 1/2" socket and a 3/8" drive ratchet, remove the truss head screws that hold the jack support tubes to the jack shafts. When reinstalling, torque the truss head screws to 23 ± 3 ft-lb.
4. Insert a fine-thread 7/16"-20 bolt far enough into the top of the jack supports to separate the litter top from the jack shaft.
5. With the assistance of another person, lift the litter straight up to remove it from the jack shafts and set it aside.
6. Reverse steps to reinstall the litter.
7. Verify proper operation of the unit before returning it to service.

Service Information

TRANSFER BOARD COUNTERBALANCE ADJUSTMENT

Tools Required:

- 7/16" Combination Wrench

Procedure:

1. Raise the transfer board to the full up position.
2. Unhook the extension spring at the eye bolt.
3. Using a 7/16" combination wrench, loosen the jam nut at the eye bolt.
4. Adjust the eye bolt to the desired position.
5. Tighten the jam nut.
6. Hook the extension spring to eye bolt.
7. Allow the transfer board to lower on its own.
8. Repeat steps until the desired counterbalance is achieved.

FOLD DOWN SIDERAIL LATCH ADJUSTMENT

Tools Required:

- 1/8" Hex Allen Wrench



WARNING

The siderail latches are preset at the factory, and do not normally need adjustment. If adjustment must be done, it is important to follow the procedure below. If adjustment is not done properly, injury to the patient or user could result.

Procedure:

1. Using a 1/8" hex Allen wrench, adjust the hex Allen screw located on the latch assembly opposite the latch. Turning the screw clockwise will **decrease** the amount of "play" in the latching mechanism. Turning counterclockwise will **increase** the amount.

Note: The amount of "play" in the siderail, when in full up engaged position, should be approximately 1/8" to 3/16" inches.



CAUTION

Too much "play" when the siderail is in the full up engaged position will give the siderail the appearance of being unstable and could also cause premature wearing of the latch system.

Too little "play" will obstruct the latch and keep it from engaging completely in the full up position, which may result in damage to the latch and/or injury to the patient or user.

Service Information

RELEASE PEDAL REPLACEMENT, FOOT END

Tools Required:

- Needle-Nose Pliers

Procedure:

1. Apply the stretcher brakes.
2. Disconnect the release pedal return springs from the foot end release pedals.
3. Remove the rue ring cotters and the clevis pins that connect the foot end release pedals to the mounting bracket.
4. Rotate the pedals upward.
5. Remove the rue ring cotters that connect the head end and foot end release rods to the foot end release pedals and remove the pedals.
6. Reverse steps to install the new pedals.
7. Verify proper operation of the unit before returning it to service.

RELEASE PEDAL ROD REMOVAL, FOOT END

Tools Required:

- Needle-Nose Pliers

Procedure:

1. Remove the foot end release pedal. See “Release Pedal Replacement, Foot End” [on page 31](#).
2. Remove the snap in nyliners that hold the foot end pedal release rods into the pedal mounting bracket.
3. Unsnap the foot end pedal release rods from the white plastic release rod brackets.
4. Dislodge the side control release pedal swivels from the studs on the side control release pedal weldment.
5. Remove the foot end pedal release rods.
6. Reverse steps to reinstall the pedal rods.
7. Verify proper operation of the unit before returning it to service.

Service Information

BIG WHEEL REMOVAL (NON FOUR-SIDED BRAKES)

Tools Required:

- Large Standard Screwdriver
- Small Standard Screwdriver
- Bungee Cords

Procedure:

1. Lift the base hood and separate the Velcro that holds the base hood to the base frame. Support the hood from the litter using bungee cords so it is out of the way.
2. Using a large standard screwdriver, remove the hub cap in the center of the wheel.
3. Using a small standard screwdriver, remove the spiral retaining ring from the groove on the wheel axle.
4. Remove the Big Wheel.
5. Reverse steps to reinstall the Big Wheel.
6. Verify proper operation of the unit before returning it to service.

BIG WHEEL REMOVAL (FOUR-SIDED BRAKES)

Tools Required:

- Large Standard Screwdriver
- 7/32" Roll Pin Punch
- Bungee Cords

Procedure:

1. Lift the base hood and separate the Velcro that holds the base hood to the base frame. Support the hood from the litter using bungee cords so it is out of the way.
2. Using a large standard screwdriver, remove the hub cap in the center of the wheel.
3. Using a 7/32" roll pin punch, remove the tapered groove pin from the pedal.

Note: The pin is tapered, so it must be driven from the bottom up.

4. Remove the Big Wheel.
5. Reverse steps to reinstall the Big Wheel.
6. Verify proper operation of the unit before returning it to service.

Service Information

BIG WHEEL DAMPENER REPLACEMENT

Tools Required:

- Bungee Cords
- Needle Nose Pliers
- Standard Screwdriver
- 3/8" Drive Torque Wrench (ft-lb)
- 7/16"-20 Bolt

Procedure:

1. Pump the stretcher all the way up.
2. Raise the left and right siderails to the up and latched position.
3. Using bungee cords, raise the base hood and support.
4. Put the unit into neutral.
5. Using needle nose pliers, remove the big wheel drive link rue clip and clevis pin from the lift cam and flip the lift cam out of the way.
6. Using needle nose pliers, remove the rue clip and clevis pin from the gas cylinder.
7. Using your hand, grab the lift cam and pull it upward with the gas cylinder.
8. Using needle nose pliers, remove the rue clip and clevis pin from the dampener arm.
9. Using needle nose pliers, remove the rue clip and washer and discard the gas cylinder.
10. Reverse the above steps for installation of the new brake timing link.
11. Verify proper operation of the unit before returning it to service.

Service Information

PNEUMATIC FOWLER ADJUSTMENT

Tools Required:

- 5/32" Allen Wrench
- 1/2" Combination Wrench

Procedure:

1. Raise the fowler to 75 degrees or higher.
2. Using a 1/2" combination wrench, loosen the hex nuts in the actuator arms on the end of the trip bar.
3. To adjust the fowler, use a 5/32" hex Allen wrench to turn the Allen screws counter-clockwise or clockwise. If the fowler will not move, turn the screws 1 to 2 turns counter-clockwise. If the fowler will not hold its position, turn the screws 1 to 2 turns clockwise.
4. Retighten the hex nuts. Make sure that the fowler travels from flat up to 90 degrees and down again and that it holds its position when weight is applied before returning the stretcher to service.
5. Verify proper operation of the unit before returning it to service.

Service Information

REMOVAL OF EXCESS AIR FROM THE HYDRAULIC SYSTEM

Tools Required:

- None

Procedure:

1. Verify that all hydraulic linkages are secure and operating properly.
2. Raise the litter to its highest height.
3. Continue to pump the pedal several times to force the air through the system.
4. Verify proper operation before returning the unit to service.

Fifth Wheel Standard Brake Assembly

1105-003-205 Rev A (Reference Only)

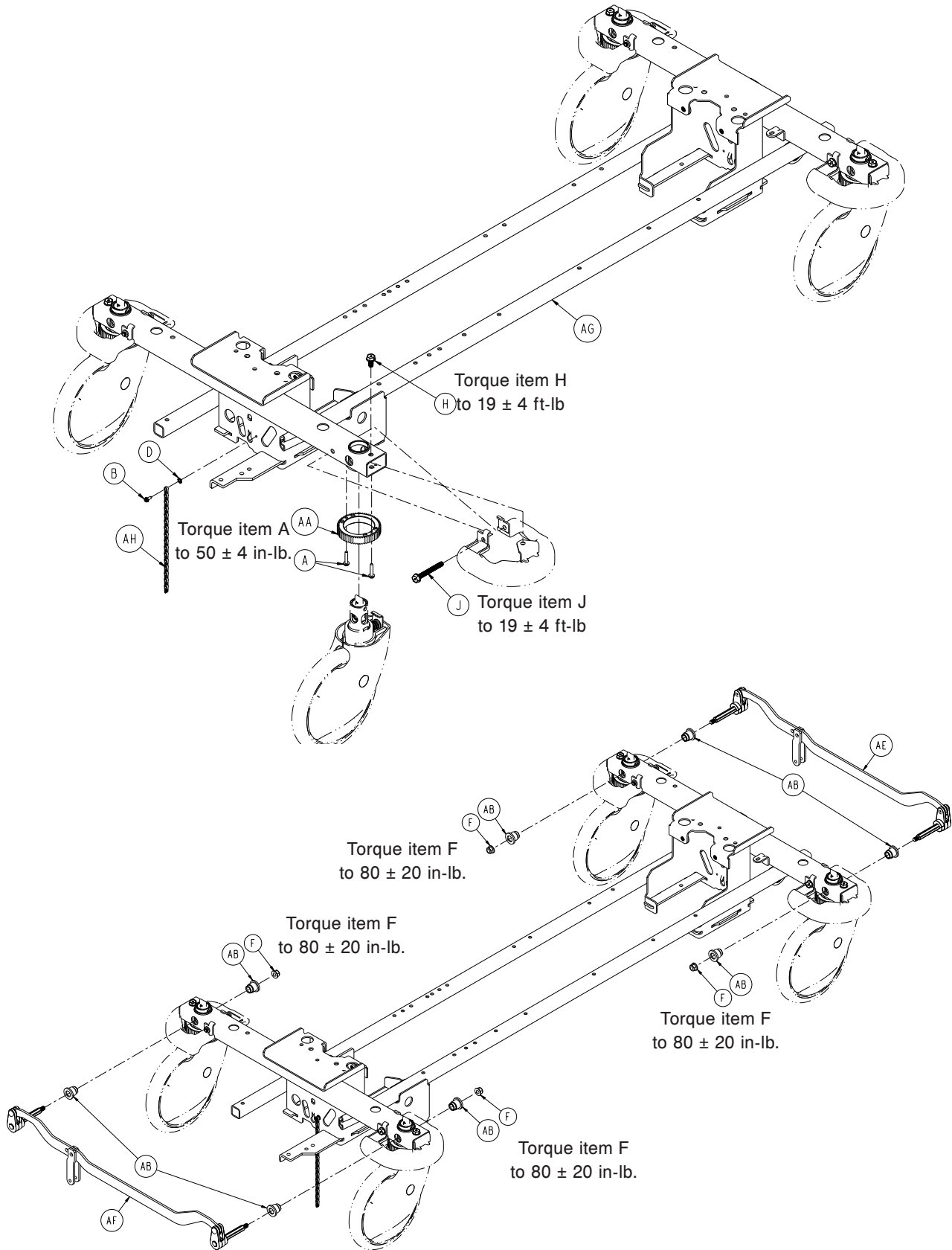

[Return To Table of Contents](#)

Fifth Wheel Standard Brake Assembly

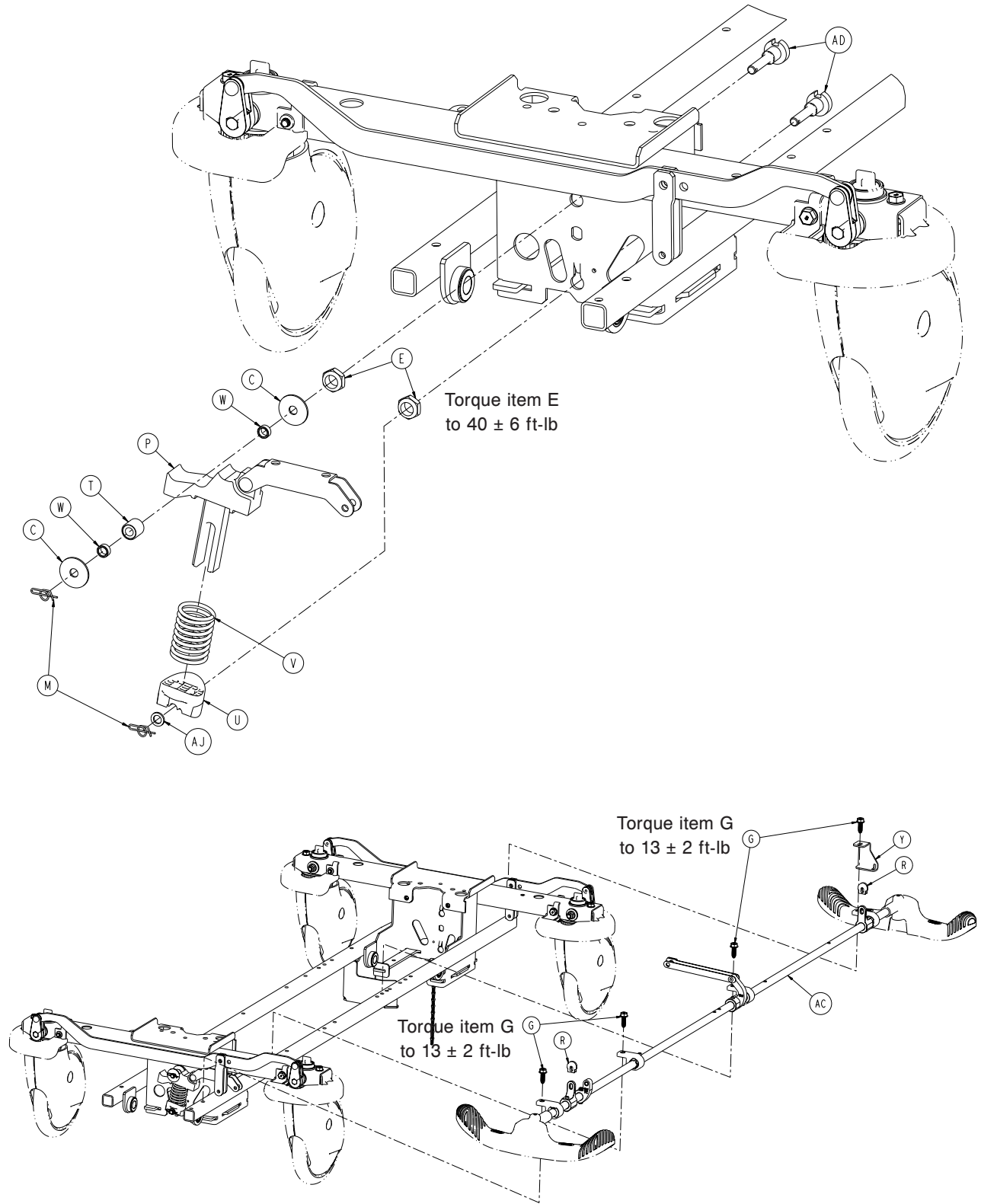

[Return To Table of Contents](#)

Fifth Wheel Standard Brake Assembly

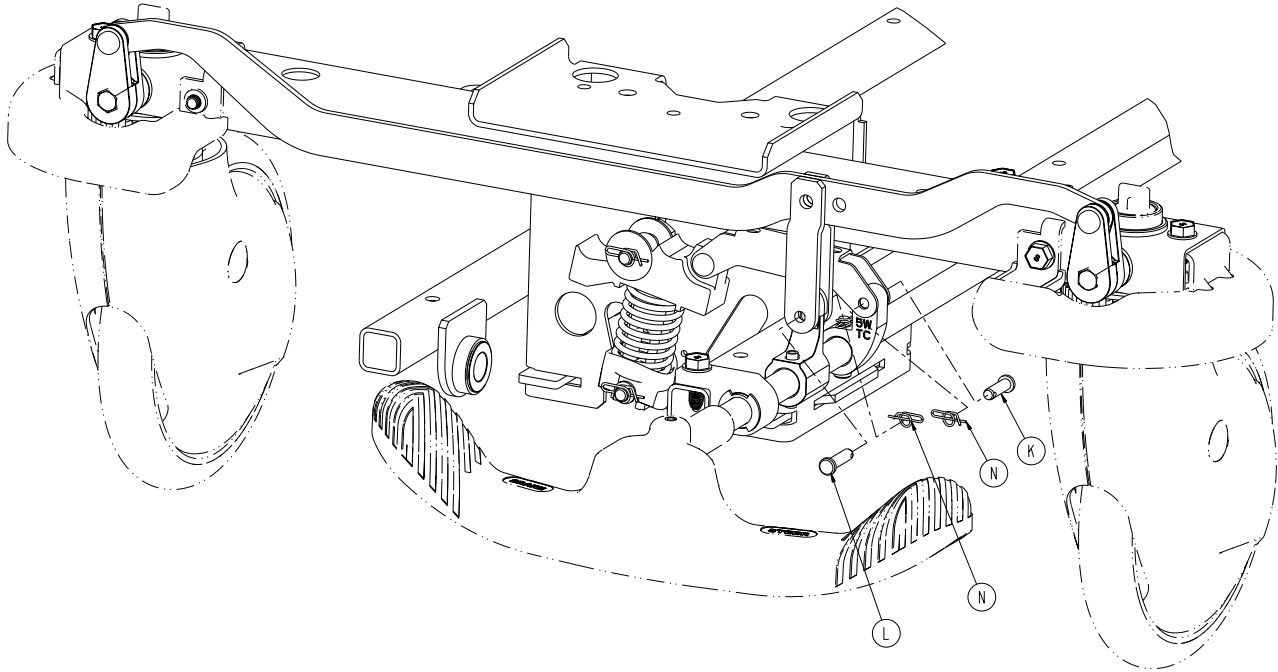

Fifth Wheel Standard Brake Assembly - 1105-003-205 Rev A (Reference Only)

Item	Part No.	Part Name	Qty.
A	0003-147-000	Hex Washer Head Screw	8
B	0003-364-000	Hex Washer Head Truss Screw	1
C	0011-263-000	Washer	2
D	0013-018-000	External Tooth Lock Washer	1
E	0016-049-000	Nylock Hex Nut	2
F	0016-135-000	Nylock Flange Hex Nut	4
G	0023-288-000	Hex Washer Head Screw	4
H	0023-330-000	Hex Washer Head Screw	4
J	0023-331-000	Hex Washer Head Screw	4
K	0026-295-000	Clevis Pin	1
L	0026-393-000	Clevis Pin	2
M	0027-019-000	Rue Ring Cotter	2
N	0027-020-000	Rue Ring Cotter	3
P	0853-003-035	Brake Cam and Link Assembly	1
R	0853-003-064	Brake Rod Crank Cap	2
T	0853-003-075	Timing Cam Bearing Assembly	1
U	0853-003-103	Timing Cam Spring Retainer	1
V	0853-003-104	Fifth Wheel Timing Cam Spring	1
W	0853-003-131	Timing Cam Spacer	2
Y	1105-005-087	Return Spring Hook	1
AA	0853-102-003	Caster Steer Lock Gear	4
AB	0853-102-004	Stepped Flange Bearing	8
AC	0853-203-201	Brake Rod Assembly (page 39)	1
AD	0853-203-230	Bearing Pivot Support	2
AE	0853-303-010	Brake Link Assembly, Head End	1
AF	0853-303-020	Brake Link Assembly, Foot End	1
AG	0853-401-001	Base Weldment	1
AH	3001-200-052	Grounding Chain	1
AJ	0014-003-000	Washer	1

[Return To Table of Contents](#)

Fifth Wheel Brake Rod Assembly

0853-203-201 Rev B (Reference Only)

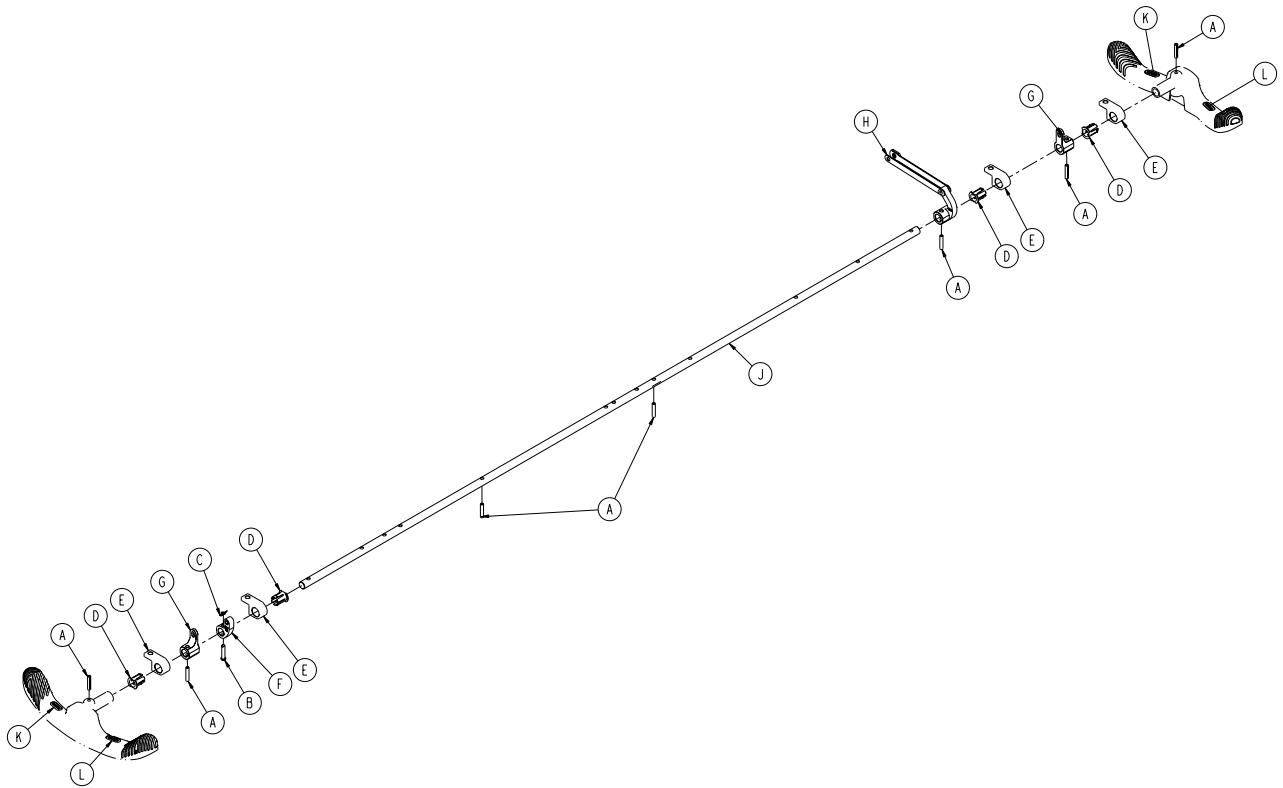

Item	Part No.	Part Name	Qty.
A	0026-014-000	Slotted Spring Pin	7
B	0026-251-000	Clevis Pin	1
C	0027-020-000	Rue Ring Cotter	1
D	0753-003-015	Brake Rod Nyliner	4
E	0853-003-004	Brake Rod Support	4
F	0853-003-055	Fifth Wheel Timing Cam Crank Assy	1
G	0853-203-011	Brake Activation Crank	2
H	0853-206-135	Fifth Wheel Drive Link Assy (page 40)	1
J	0853-303-014	Brake Rod	1
K	1105-001-335	Label, Brake (Red)	2
L	1105-001-336	Label, Steer (Green)	2

[Return To Table of Contents](#)

Fifth Wheel Drive Link Assembly - 0853-206-135

Rev E

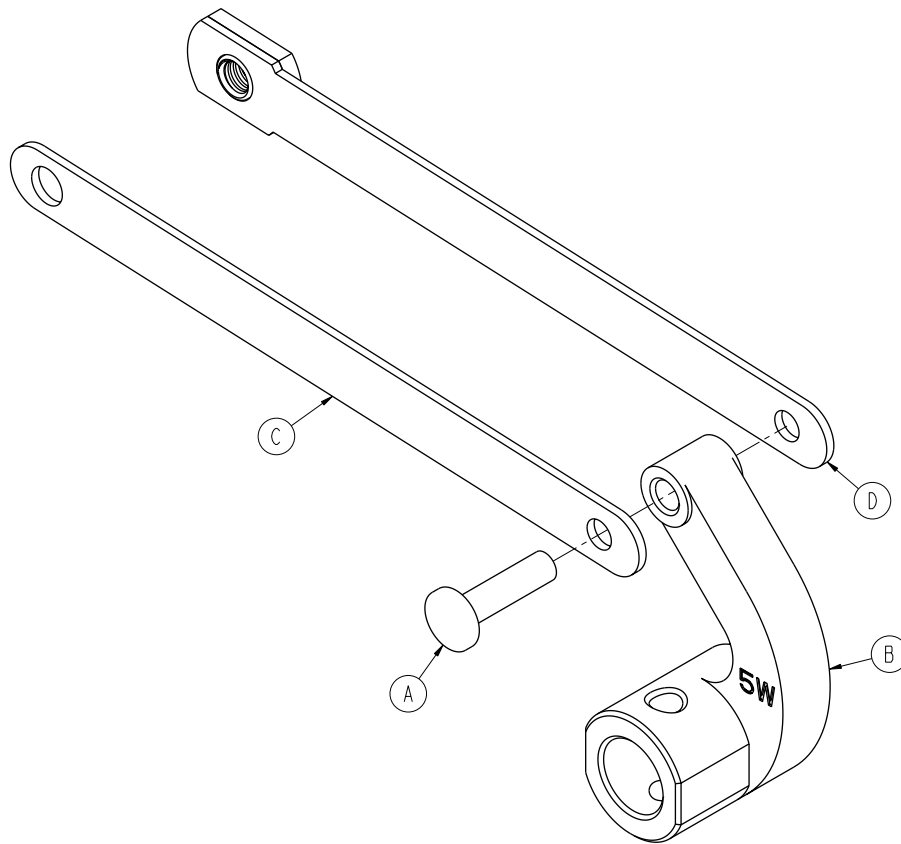

Item	Part No.	Part Name	Qty.
A	0753-003-098	Rivet	1
B	0853-206-011	Brake Rod Drive Link	1
C	0853-206-022	Fifth Wheel Cam Drive Link	1
D	0853-206-047	Fifth Wheel Cam Drive Link	1

Fifth Wheel Side Control Brake Assembly

1105-003-220 Rev A (Reference Only)

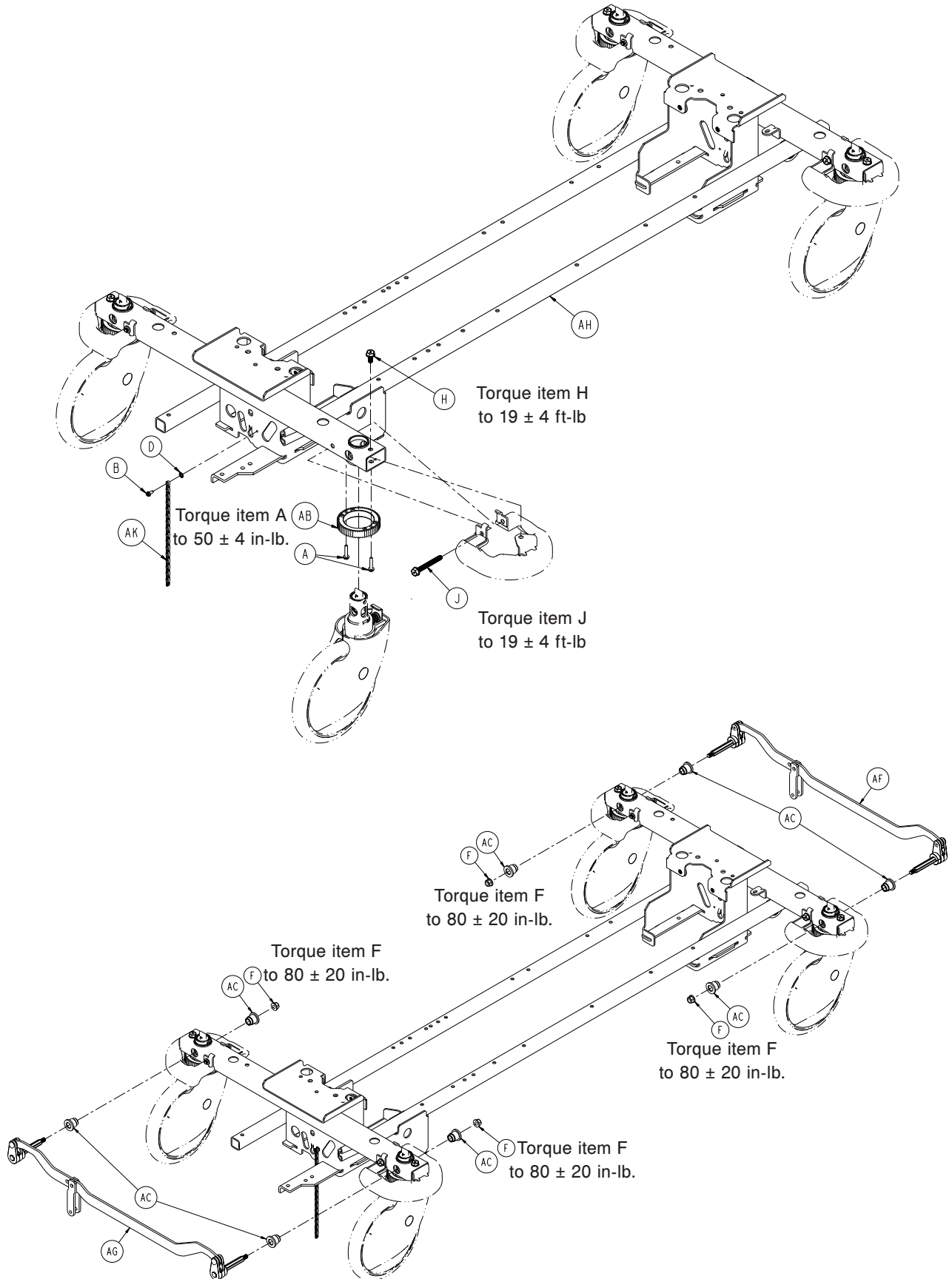

[Return To Table of Contents](#)

Fifth Wheel Side Control Brake Assembly

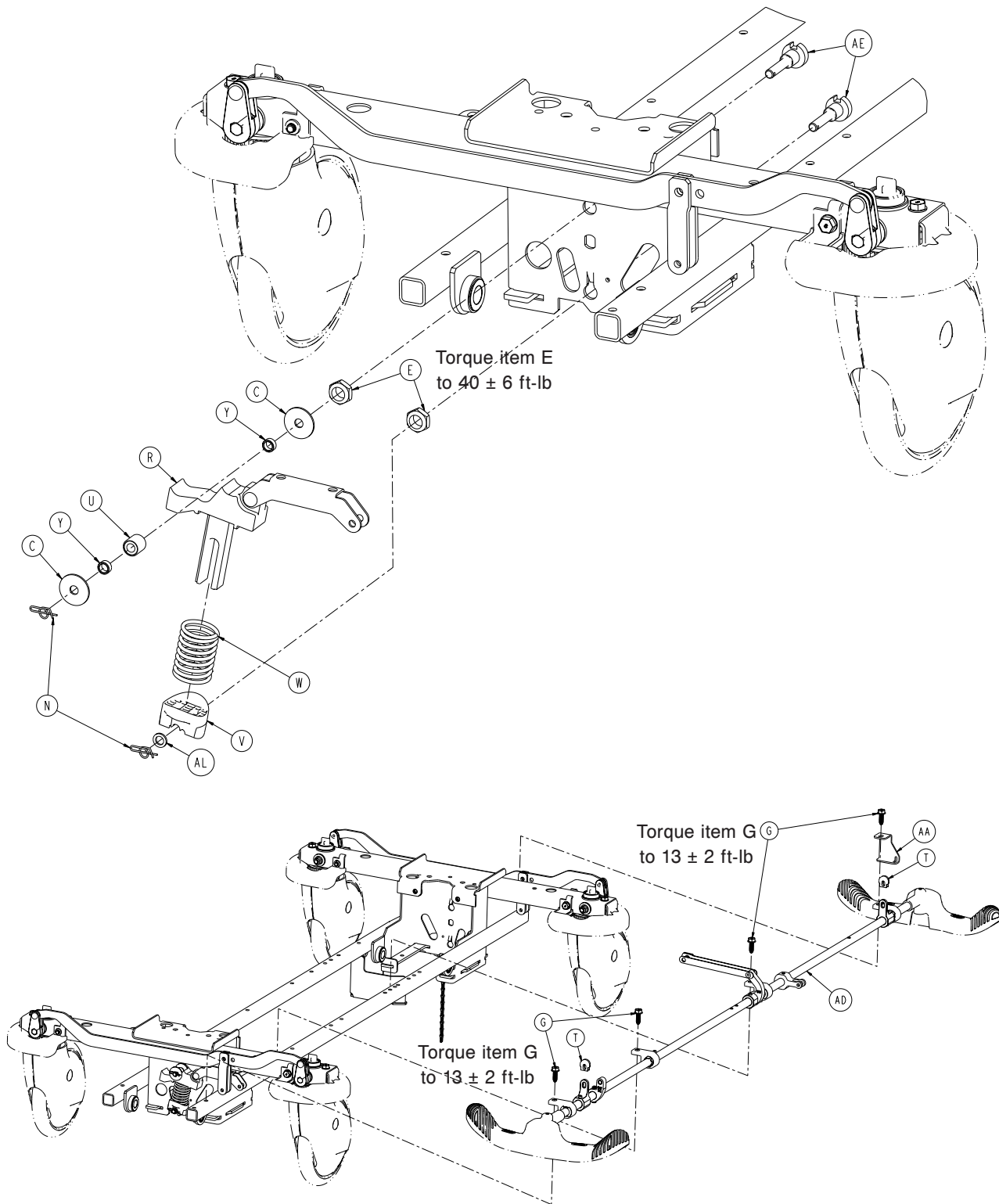

Fifth Wheel Side Control Brake Assembly

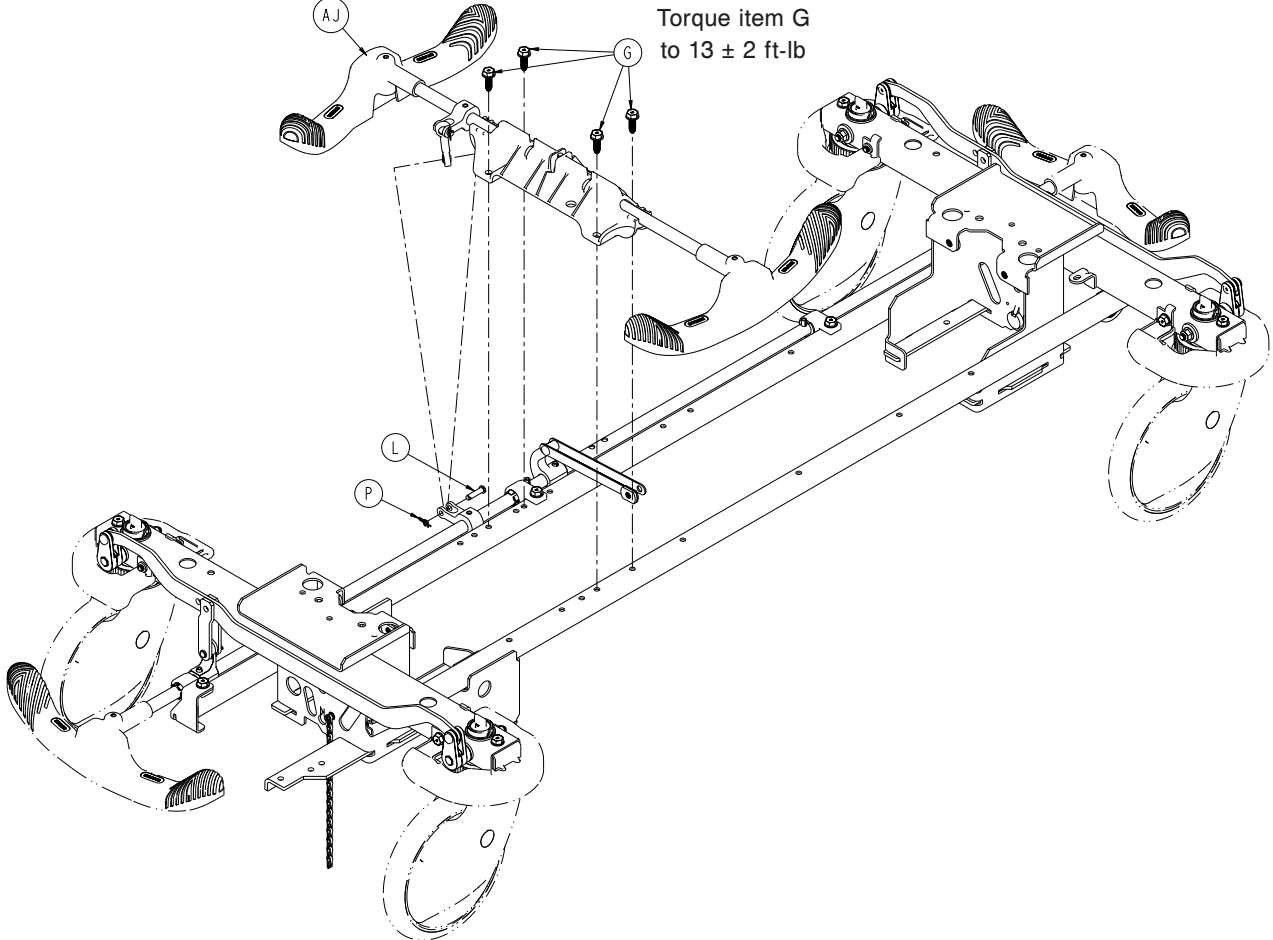
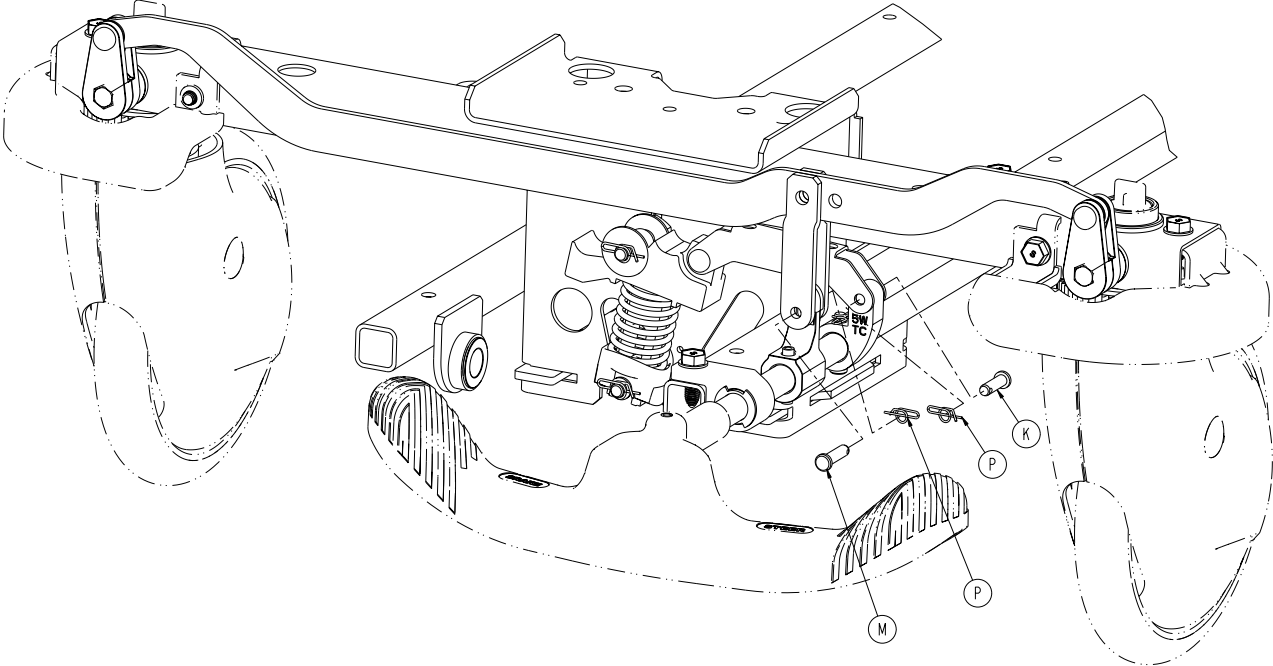

[Return To Table of Contents](#)

Fifth Wheel Side Control Brake Assembly

Fifth Wheel Side Control Brake Assembly - 1105-003-220 Rev A (Reference Only)

Item	Part No.	Part Name	Qty.
A	0003-147-000	Hex Washer Head Screw	8
B	0003-364-000	Hex Washer Head Truss Screw	1
C	0011-263-000	Washer	2
D	0013-018-000	External Tooth Lock Washer	1
E	0016-049-000	Nylock Hex Nut	2
F	0016-135-000	Nylock Flange Hex Nut	4
G	0023-288-000	Hex Washer Head Screw	8
H	0023-330-000	Hex Washer Head Screw	4
J	0023-331-000	Hex Washer Head Screw	4
K	0026-295-000	Clevis Pin	1
L	0026-340-000	Clevis Pin	1
M	0026-393-000	Clevis Pin	2
N	0027-019-000	Rue Ring Cotter	2
P	0027-020-000	Rue Ring Cotter	4
R	0853-003-035	Brake Cam and Link Assembly	1
T	0853-003-064	Brake Rod Crank Cap	2
U	0853-003-075	Timing Cam Bearing Assembly	1
V	0853-003-103	Timing Cam Spring Retainer	1
W	0853-003-104	Fifth Wheel Timing Cam Spring	1
Y	0853-003-131	Timing Cam Spacer	2
AA	1105-005-087	Return Spring Hook	1
AB	0853-102-003	Caster Steer Lock Gear	4
AC	0853-102-004	Stepped Flange Bearing	8
AD	0853-203-225	Brake Rod/Side Control Assembly (page 45)	1
AE	0853-203-230	Bearing Pivot Support	2
AF	0853-303-010	Brake Link Assembly, Head End	1
AG	0853-303-020	Brake Link Assembly, Foot End	1
AH	0853-401-001	Base Weldment	1
AJ	1105-003-210	Side Control Brake Assembly (page 46)	1
AK	3001-200-052	Grounding Chain	1
AL	0014-003-000	Washer	1

Fifth Wheel Brake Rod/Side Control Assembly

0853-203-225 Rev B (Reference Only)

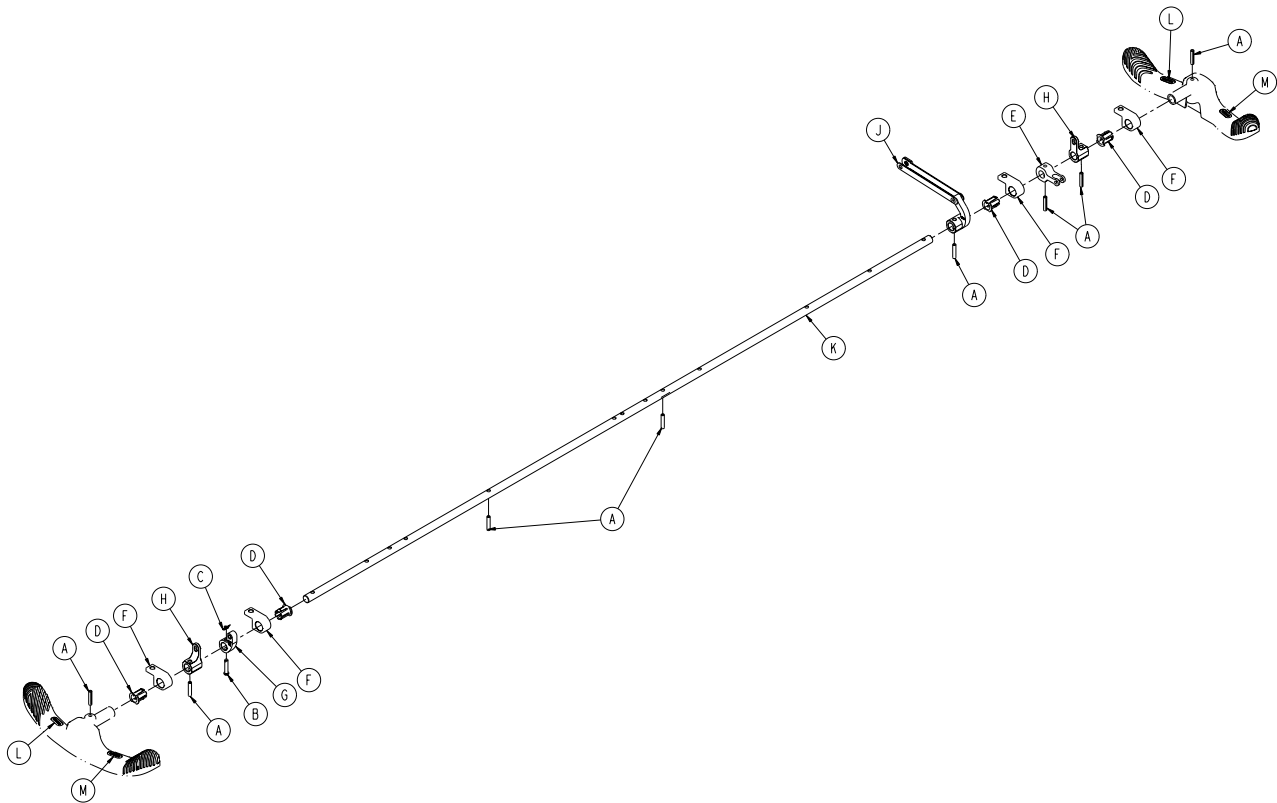

Item	Part No.	Part Name	Qty.
A	0026-014-000	Slotted Spring Pin	8
B	0026-251-000	Clevis Pin	1
C	0027-020-000	Rue Ring Cotter	1
D	0753-003-015	Brake Rod Nyliner	4
E	0753-003-112	Side Control Link	1
F	0853-003-004	Brake Rod Support	4
G	0853-003-055	Fifth Wheel Timing Cam Crank Assy	1
H	0853-203-011	Brake Activation Crank	2
J	0853-206-135	Fifth Wheel Drive Link Assy (page 40)	1
K	0853-303-014	Brake Rod	1
L	1105-001-335	Label, Brake (Red)	2
M	1105-001-336	Label, Steer (Green)	2

[Return To Table of Contents](#)

Fifth Wheel Side Control Brake Assembly

1105-003-210 Rev A (Reference Only)

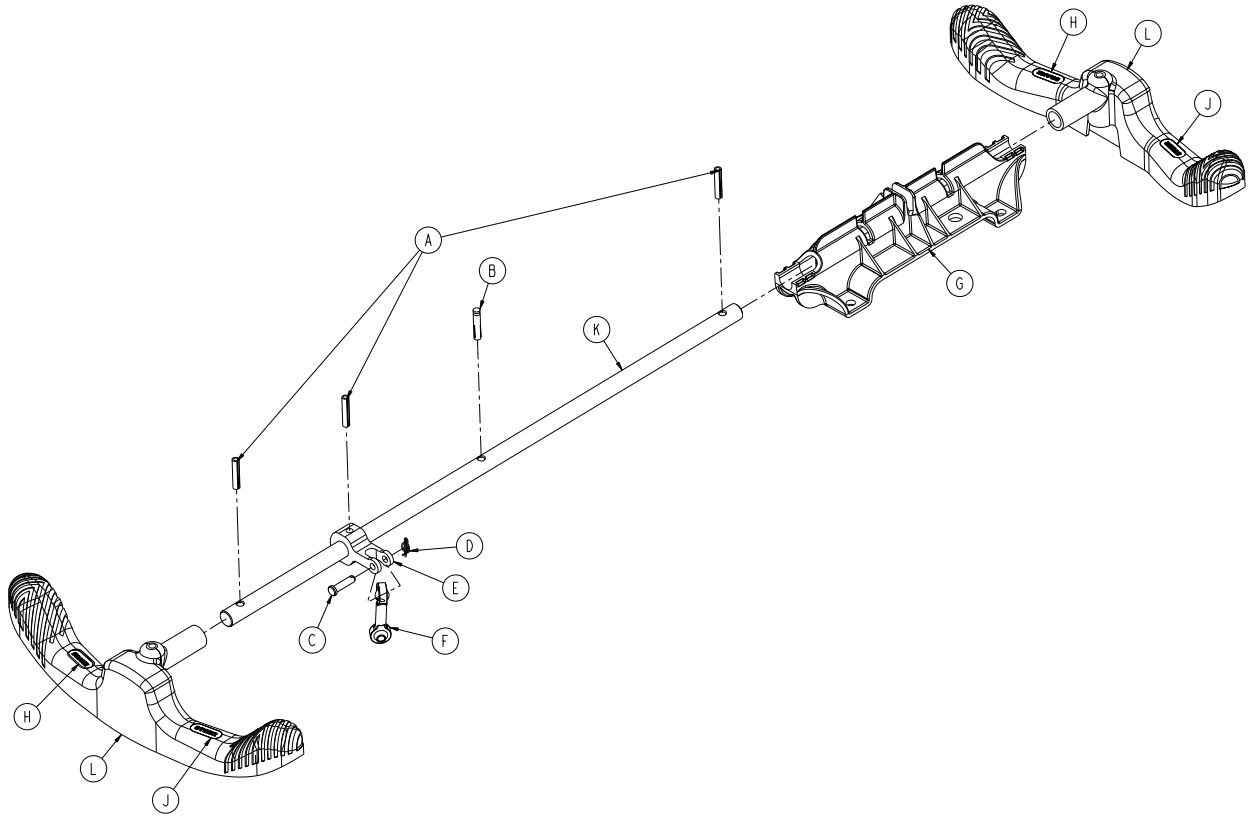

Item	Part No.	Part Name	Qty.
A	0026-014-000	Slotted Spring Pin	3
B	0026-138-000	Grooved Pin	1
C	0026-340-000	Clevis Pin	1
D	0027-020-000	Rue Ring Cotter	1
E	0753-003-112	Side Control Link	1
F	0753-003-117	Rod End Link	1
G	0853-003-214	Side Control Shaft Support	1
H	1105-001-335	Label, Brake (Red)	2
J	1105-001-336	Label, Steer (Green)	2
K	1105-003-319	Side Control Brake Rod	1
L	1105-005-154	Butterfly "V" Pedal	2

Bumper Color Options - Individual or Set of Four

0853-003-085 Rev E (Reference Only)

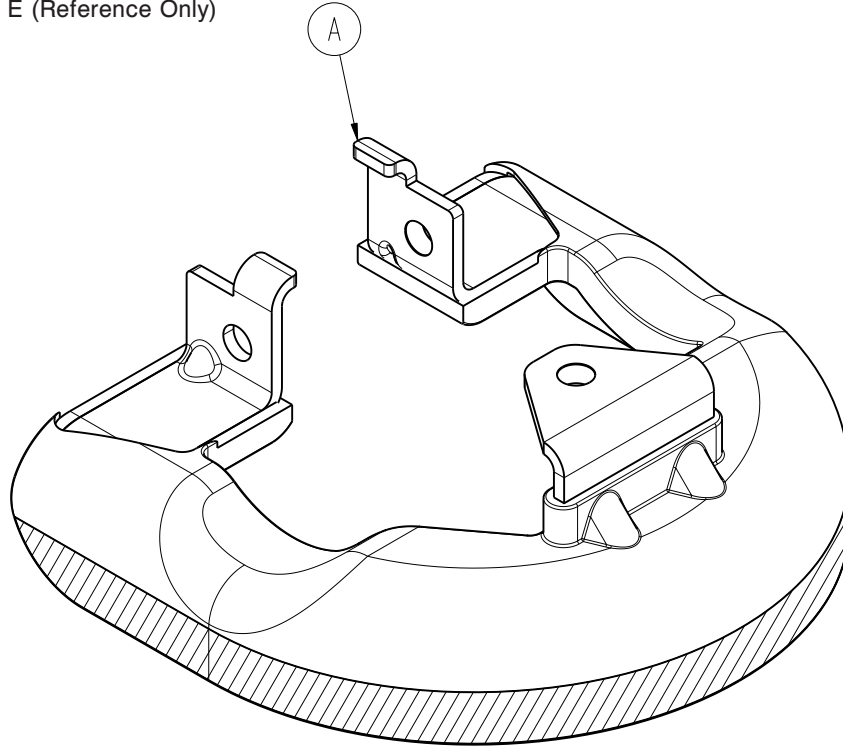

Item	Part No.	Part Name	Qty.
A	0853-003-082	Bumper	1

Bumper Color	Individual Part Number	Qty
Yellow	0853-003-551	1
Cool Grey	0853-003-552	1
Powder Blue	0853-003-553	1
Red	0853-003-554	1
Navy	0853-003-555	1
Dark Lilac	0853-003-556	1

Bumper Color	Set of Four Part Number	Qty
Yellow	1105-003-551	4
Cool Grey	1105-003-552	4
Powder Blue	1105-003-553	4
Red	1105-003-554	4
Navy	1105-003-555	4
Dark Lilac	1105-003-556	4

[Return To Table of Contents](#)

8" Caster with Full Cover Assembly - 0853-503-020

Rev B

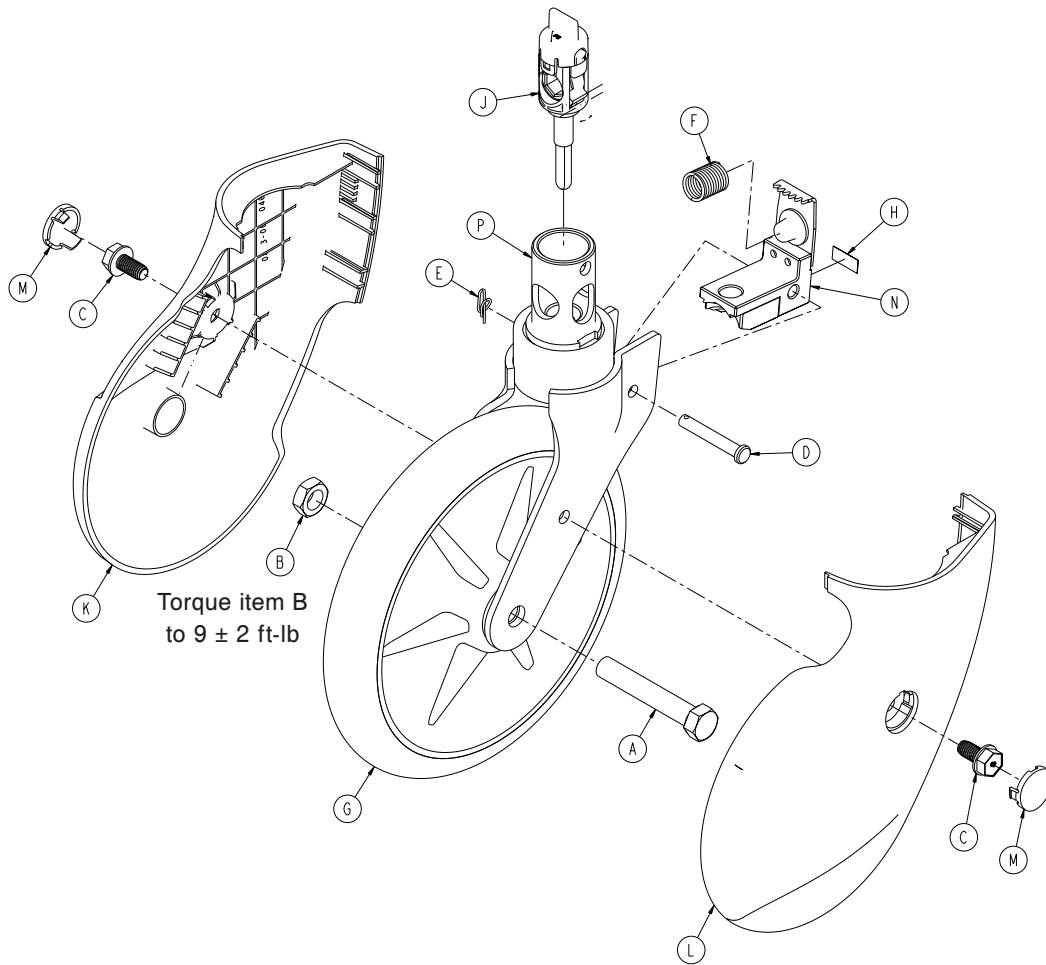

Item	Part No.	Part Name	Qty.
A	0003-099-000*	Hex Head Cap Screw	1
B	0016-060-000*	Toplock Hex Jam Nut	1
C	0023-330-000	Head Washer Head Screw	2
D	0026-377-000*	Clevis Pin	1
E	0027-020-000*	Rue Ring Cotter	1
F	0038-596-000*	Compression Wire	1
G	0753-103-215*	Molded Wheel Assembly	1
H	0853-003-032*	Label, Caster Brake Pad	1
J	0853-003-040*	Cam Housing Assembly	1
K	0853-003-046	Caster Cover - Right	1
L	0853-003-047	Caster Cover - Left	1
M	0853-003-048	Caster Cover Plug	2
N	0853-203-030*	Brake Pad Assembly	1
P	0853-303-021*	Caster Horn Assembly	1

* Shown for reference only. Individual part components are not available for sale.

Retractable Fifth Wheel Assembly

1105-006-110 Rev A (Reference Only)

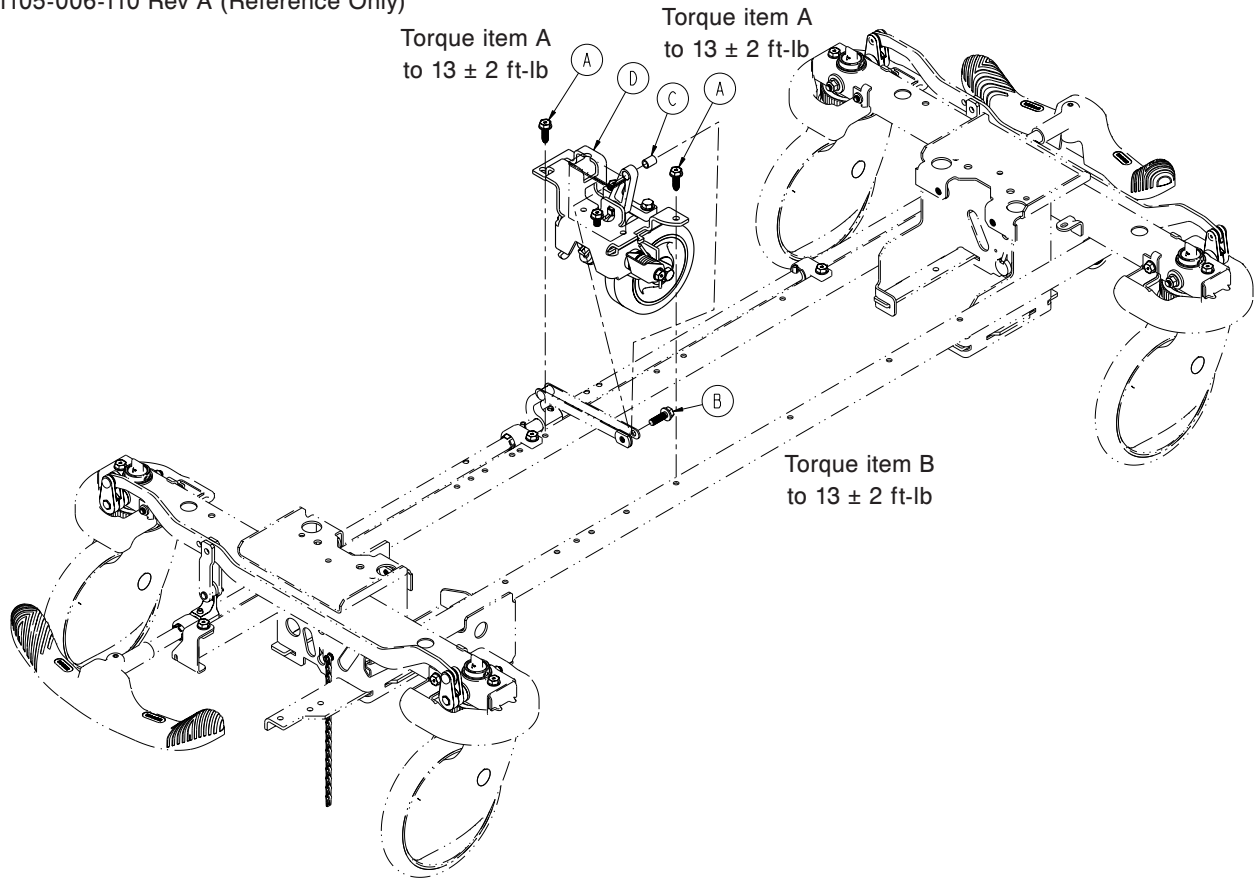

Item	Part No.	Part Name	Qty.
A	0023-288-000	Hex Washer Head Screw	2
B	0023-305-000	Hex Washer Head Screw	1
C	0753-006-148	Cam Bearing	1
D	1105-006-130	Fifth Wheel Assembly (page 50)	1

[Return To Table of Contents](#)

Fifth Wheel Assembly - 1105-006-130

Rev A

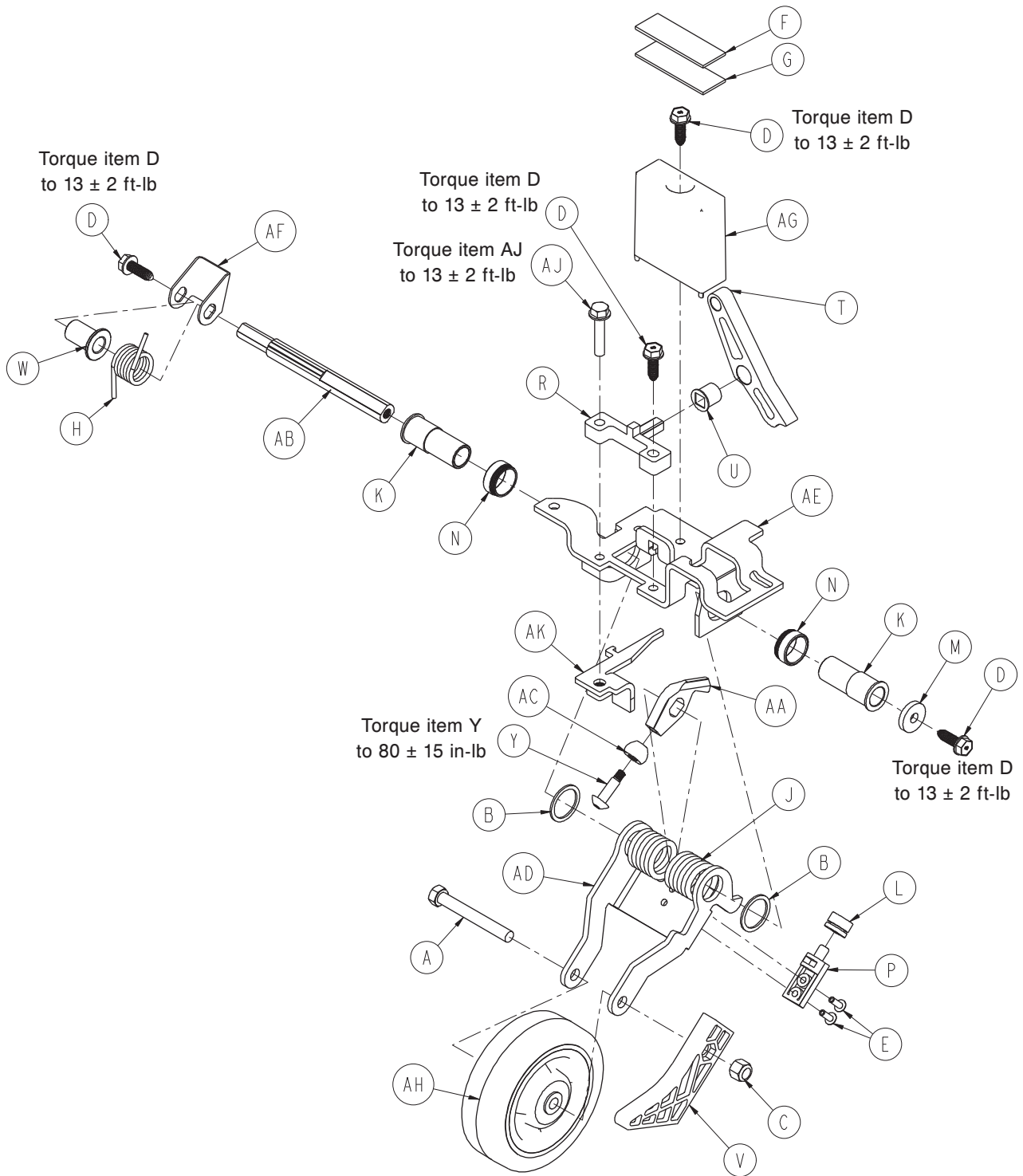

Fifth Wheel Assembly - 1105-006-130

Item	Part No.	Part Name	Qty.
A	0003-083-000	Hex Head Cap Screw	1
B	0011-360-000	Washer	2
C	0016-035-000	Nylock Hex Nut	1
D	0023-288-000	Hex Washer Head Screw	4
E	0025-050-000	Dome Head Rivet	2
F	0029-007-000	Dual Lock	1
G	0029-009-000	Dual Lock	1
H	0753-006-074	Torsion Spring	1
J	0753-006-075	Torsion Spring	1
K	0753-006-097	Drive Shaft Bearing	2
L	0753-006-106	Dampener	1
M	0753-006-108	Thrust Washer	1
N	0753-006-115	Bearing Race	2
P	0753-006-120	Bumper Mounting Pin	1
R	0753-006-133	Cam Pivot Block	1
T	0753-006-142	Fifth Wheel Cam	1
U	0753-006-143	Cam Bearing	1
V	0753-006-149	Fifth Wheel Ramp	1
W	0753-006-152	Spring Spacer	1
Y	0753-006-153	Roller Stem	1
AA	0753-006-198	Drive Pin	1
AB	0753-006-223	Drive Shaft	1
AC	0753-006-277	Roller	1
AD	1105-006-126	Fifth Wheel Bracket	1
AE	1105-006-131	Fifth Wheel Weldment	1
AF	0853-006-227	Return Spring Hook	1
AG	0853-010-045	Hood Standoff	1
AH	1210-001-147	Wheel	1
AJ	0023-160-000	Hex Washer Head Screw	1
AK	0853-006-011	Link Stop Plate	1

Fifth Wheel Dual Sided Hydraulics Assembly

1105-005-500 Rev C (Reference Only)

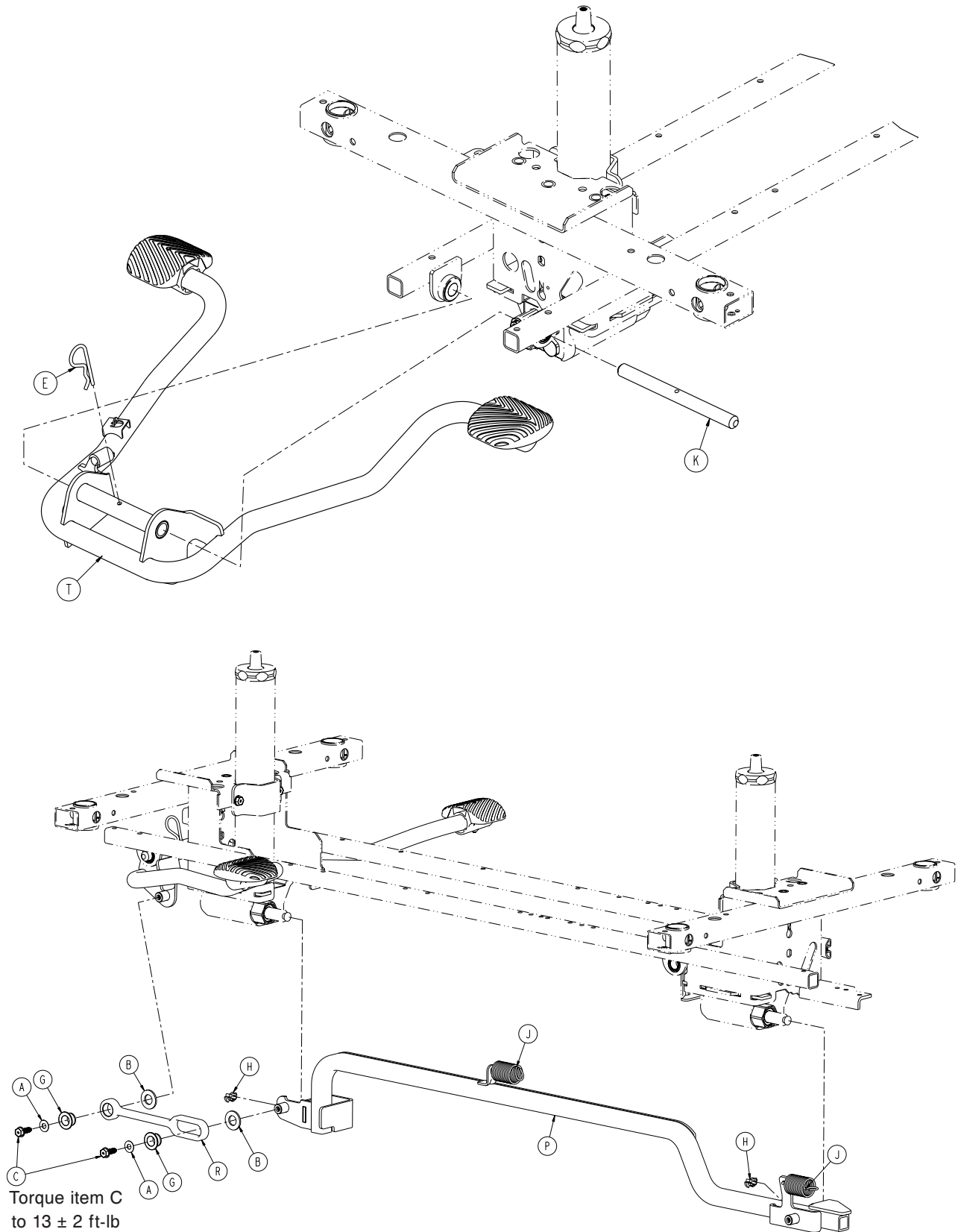

[Return To Table of Contents](#)

Fifth Wheel Dual Sided Hydraulics Assembly

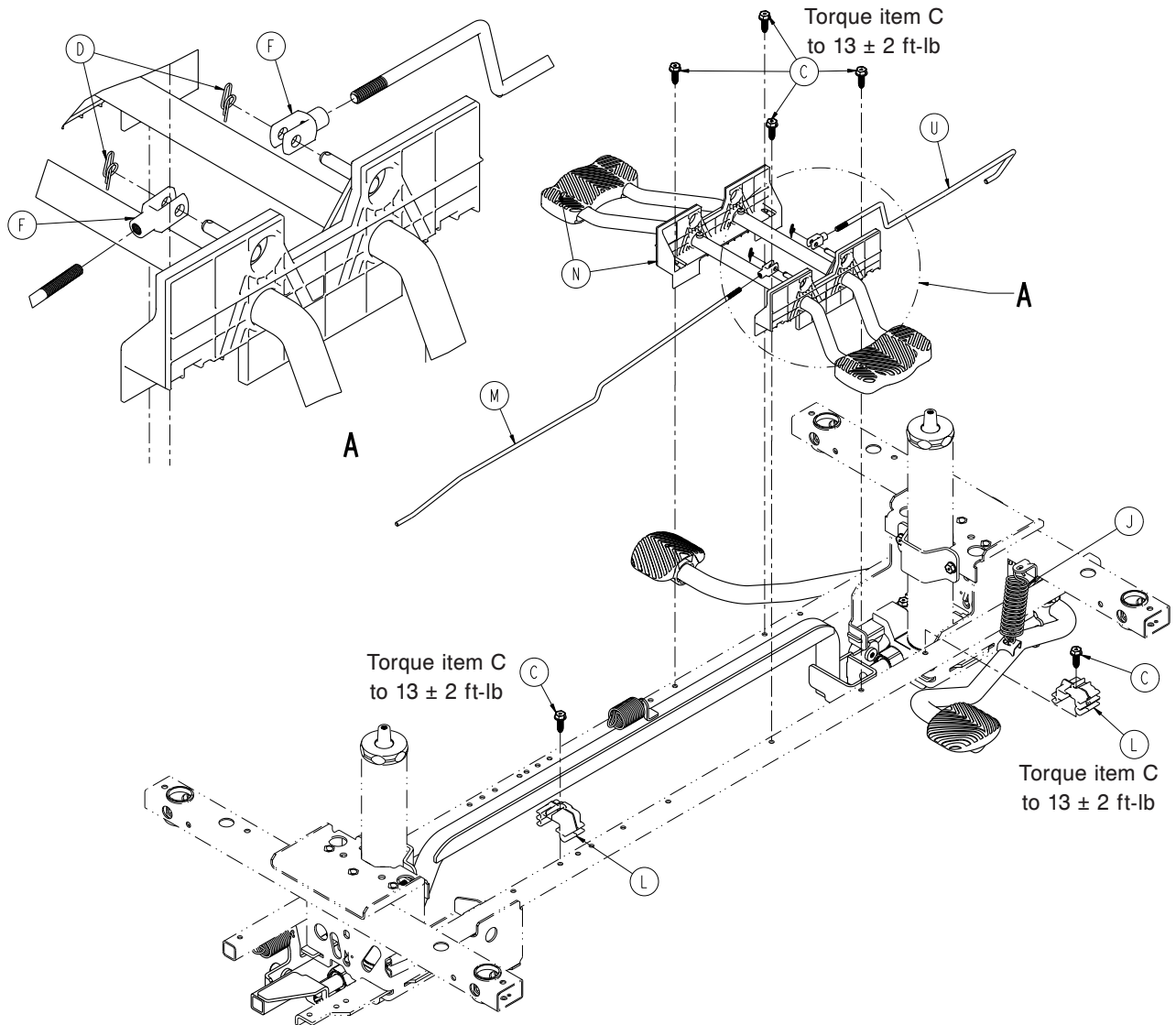

Fifth Wheel Dual Sided Hydraulics Assembly - 1105-005-500 Rev C (Reference Only)

Item	Part No.	Part Name	Qty.
A	0011-023-000	Washer	2
B	0014-071-000	Washer	2
C	0023-288-000	Hex Washer Head Screw	8
D	0027-020-000	Rue Ring Cotter	2
E	0027-031-000	Hair Pin Cotter	1
F	0052-909-000	Clevis Joint	2
G	0753-005-044	Pump Pedal Bushing	2
H	0753-005-089	Pump Ram Plug	2
J	0853-005-009	Return Spring	3
K	0853-005-074	Pivot Pin	1
L	0853-010-215	Release Rod Bracket	2
M	1105-004-015	Release Rod, Foot End	1
N	1105-004-201	Lowering Pedal Assembly (page 54)	1
P	1105-005-035	Pump Connecting Tube Weldment	1
R	1105-005-075	Pump Pedal Link	1
T	1105-005-285	Pump Pedal Assy, Head End (page 55)	1
U	0853-204-014	Release Rod, Head End	1

[Return To Table of Contents](#)

Lowering Pedal Assembly - 1105-004-201

Rev A

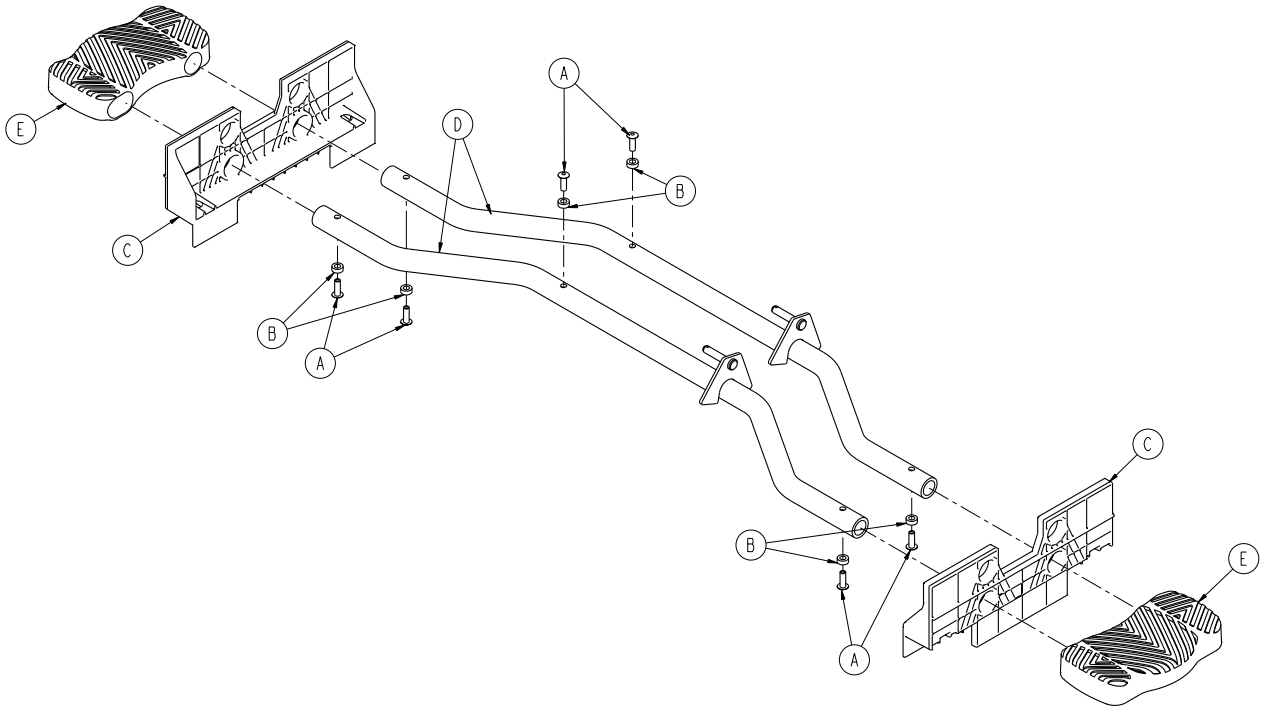

Item	Part No.	Part Name	Qty.
A	0025-133-000	Dome Head Rivet	6
B	0753-004-029	Release Pedal Standoff	6
C	0853-004-320	Release Pedal Support	2
D	1105-004-004	Release Pedal Weldment	2
E	1105-201-127	Short Uni-Pedal	2

Pump Pedal Assembly, Head End - 1105-005-285

Rev B

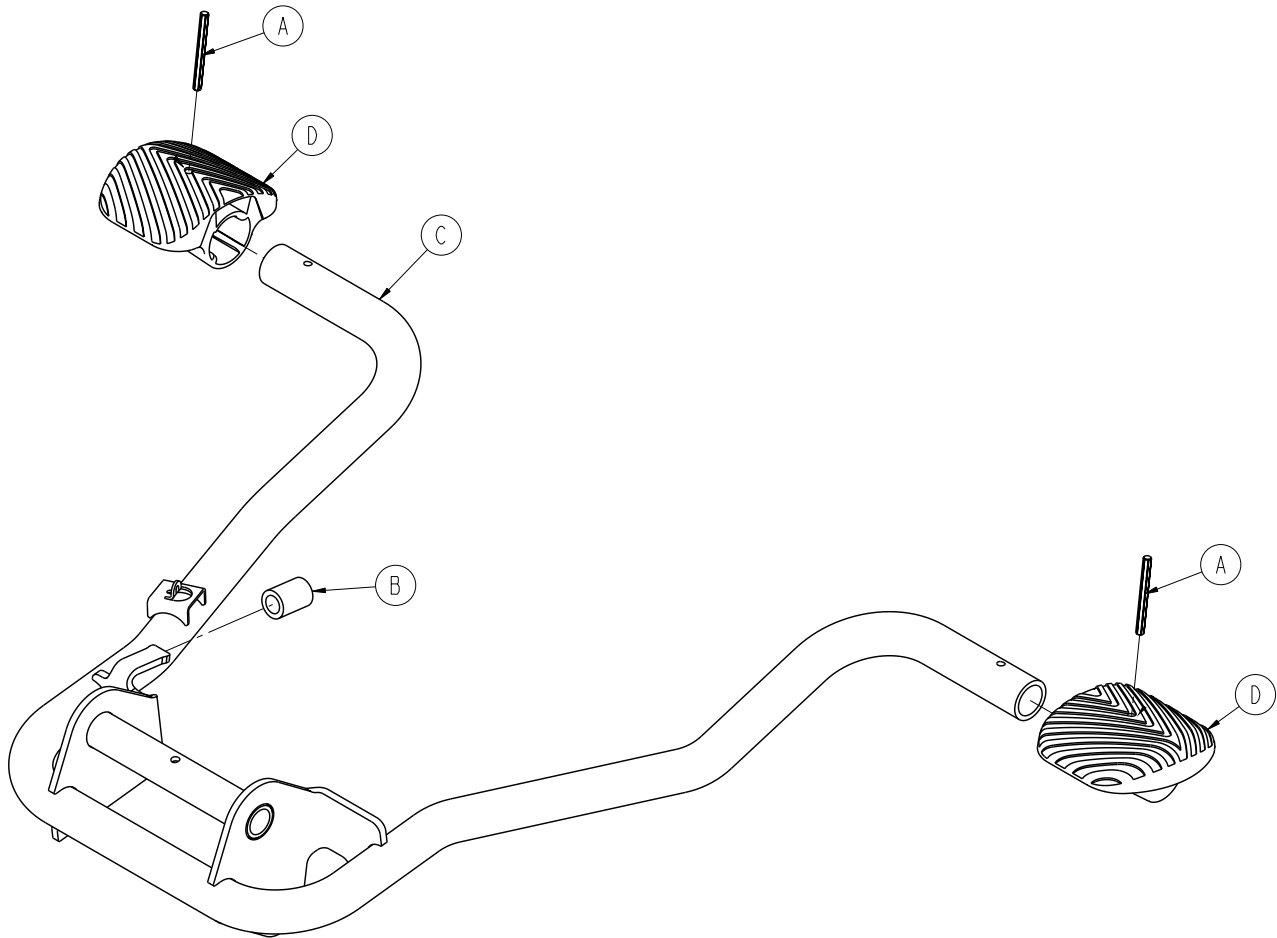

Item	Part No.	Part Name	Qty.
A	0026-343-000	Groove Pin	2
B	0715-001-140	Vinyl Tube	1
C	1105-105-180	Pump Pedal Weldment, Head End	1
D	1105-201-126	Pump Pedal	2

[Return To Table of Contents](#)

Constant Descent Jack

0853-102-025 Rev A (Reference Only)

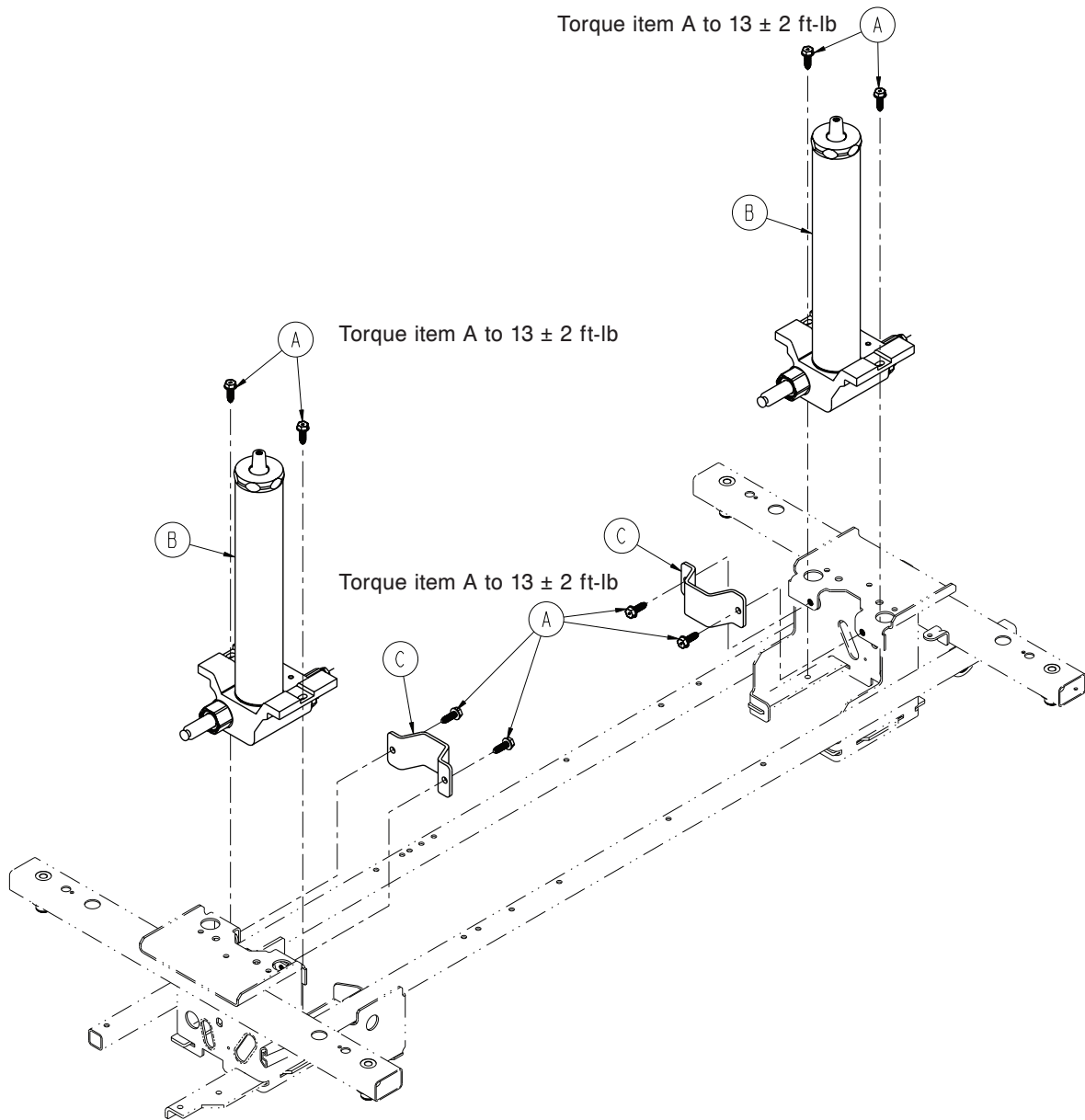

Item	Part No.	Part Name	Qty.
A	0023-288-000	Hex Washer Head Screw	8
B	0753-002-101	Constant Descent Jack Assembly	2
C	0853-010-007	Reservoir Clamp	2

Big Wheel Standard Base Assembly

1115-015-305 Rev B (Reference Only)

Torque item A
to 18 ± 3 ft-lb

Torque item A
to 18 ± 3 ft-lb

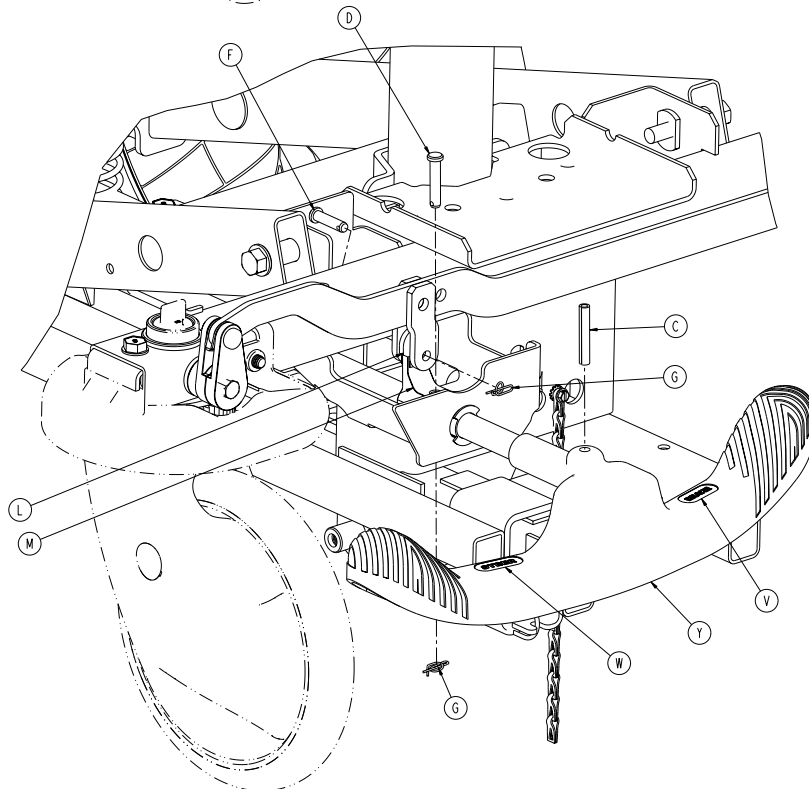
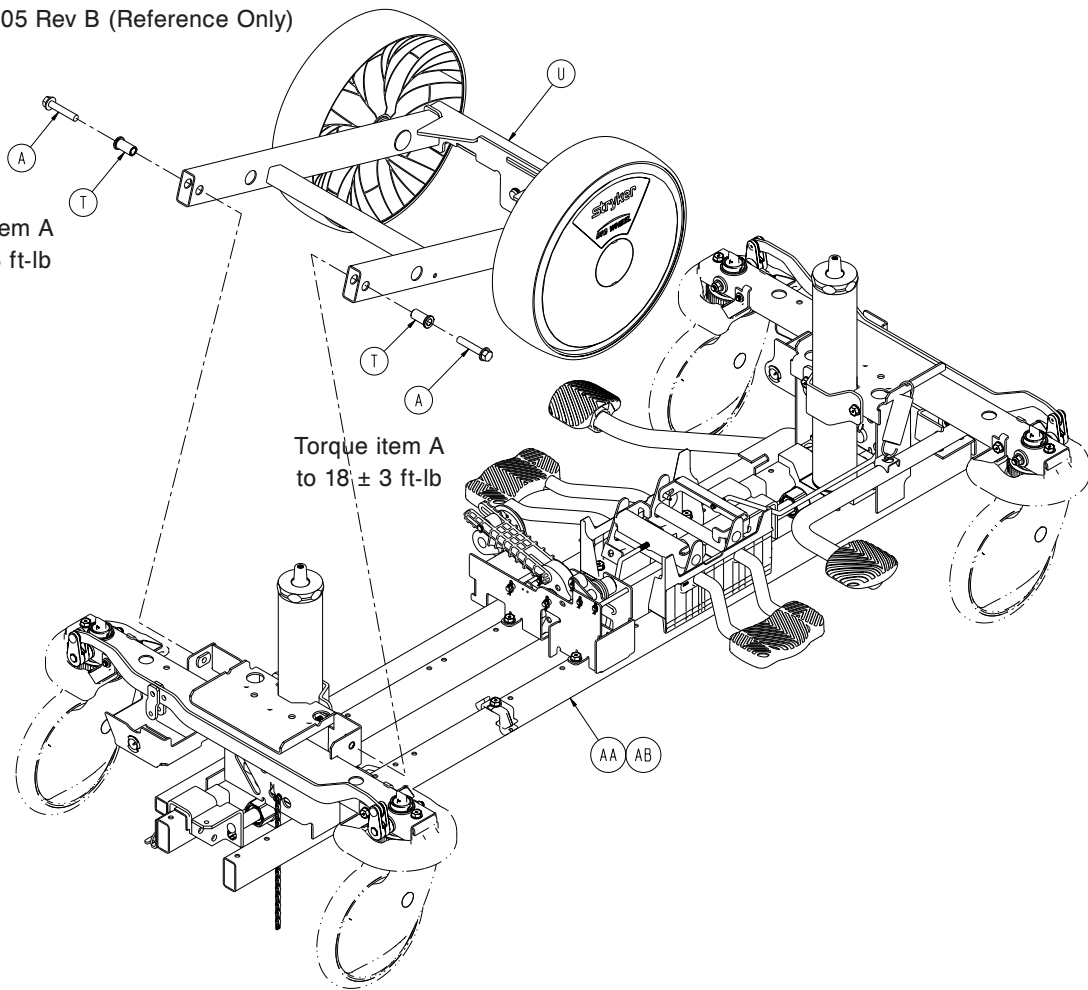

[Return To Table of Contents](#)

Big Wheel Standard Base Assembly

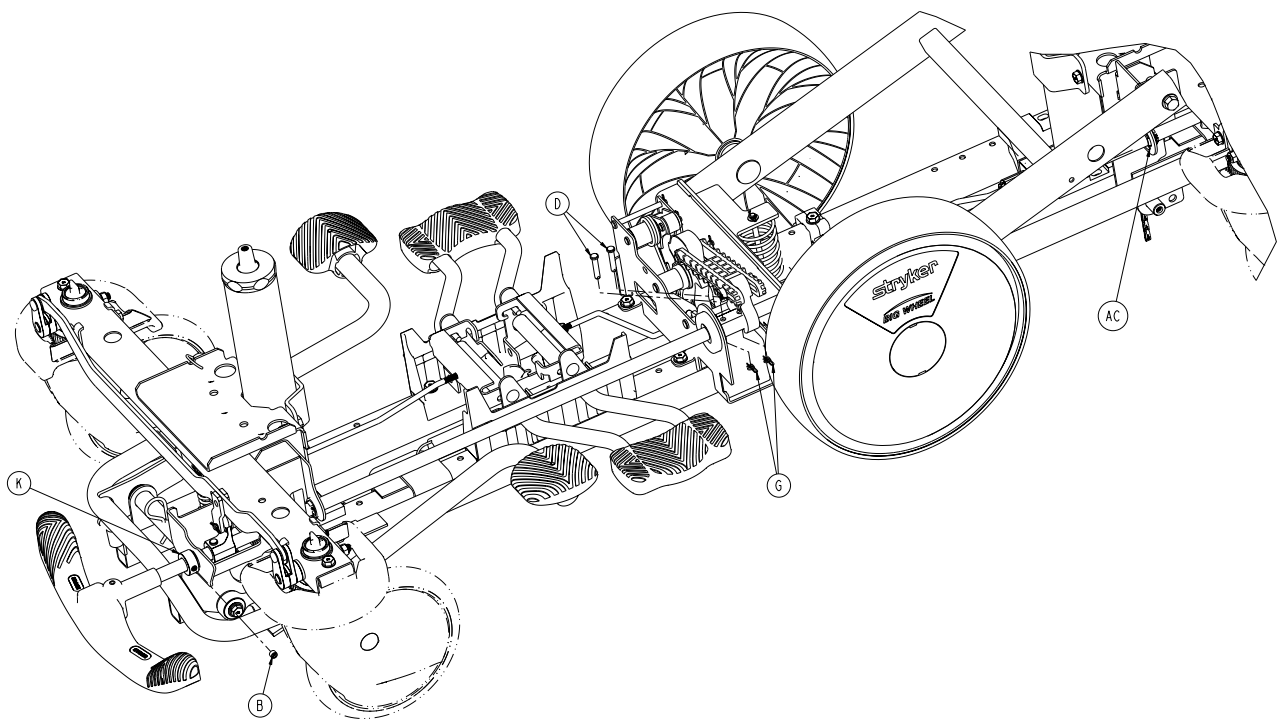
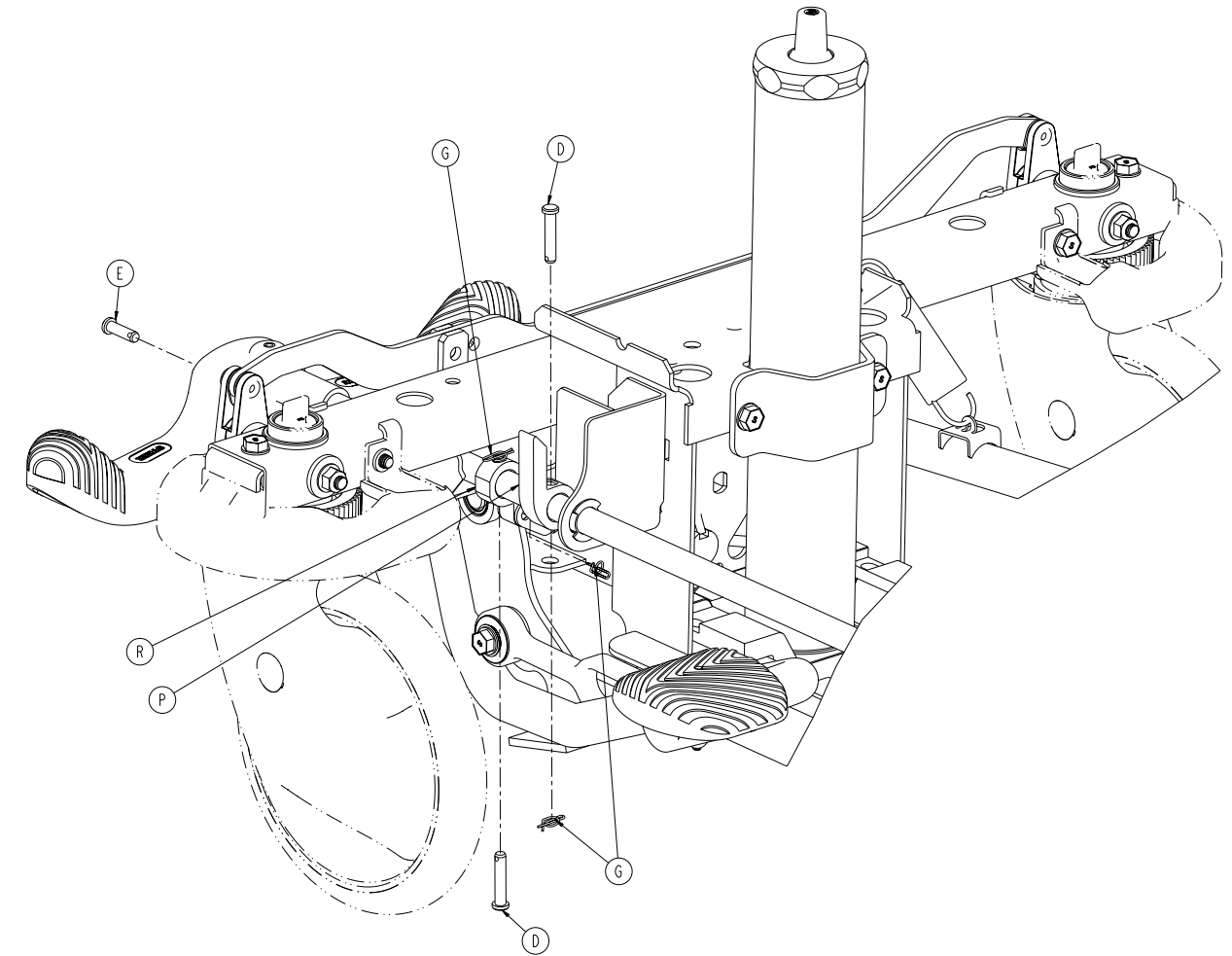

Big Wheel Standard Base Assembly

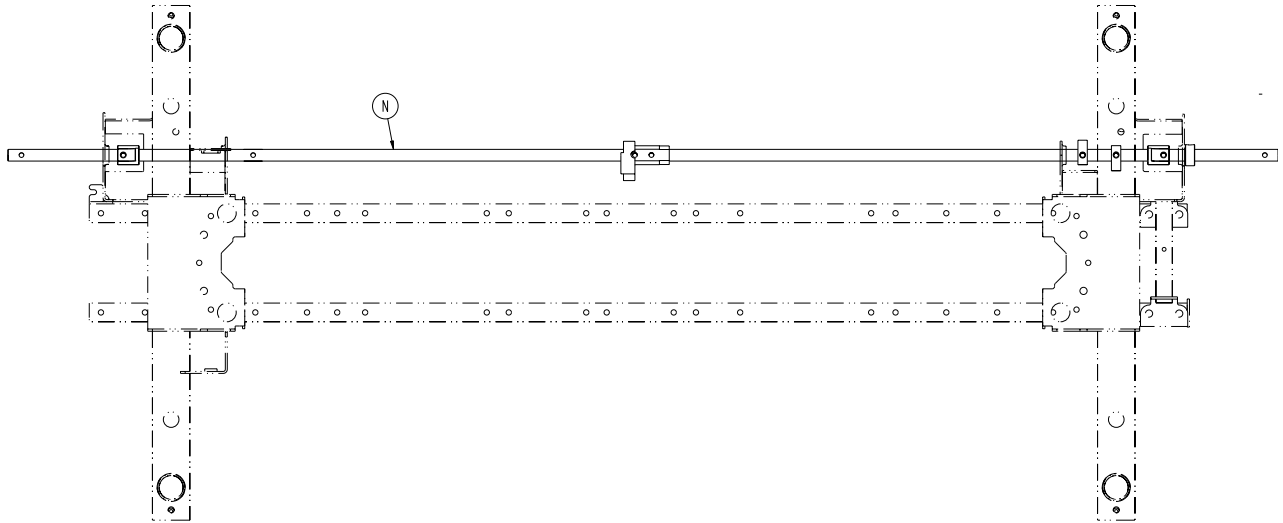

Big Wheel Standard Base Assembly - 1115-015-305 Rev B (Reference Only)

Item	Part No.	Part Name	Qty.
A	0003-381-000	Head Washer Head Truss Screw	2
B	0021-166-000	Set Screw	1
C	0026-067-000	Slotted Spring Pin	2
D	0026-251-000	Clevis Pin	6
E	0026-295-000	Clevis Pin	1
F	0026-393-000	Clevis Pin	2
G	0027-020-000	Rue Ring Cotter	9
K	0042-020-000	Collar	1
L	0853-003-064	Brake Rod Crank Cap	2
M	0853-203-011	Brake Activation Crank	2
N	1040-203-113	Brake Rod	1
P	1040-003-013	Timing Cam Hard Stop	1
R	1040-003-015	Big Wheel Timing Cam Crank Assembly	1
T	1040-115-007	Carriage Pivot Bushing	2
U	1040-215-201	Big Wheel Carriage Assembly (page 65)	1
V	1105-001-335	Label, Brake (Red)	2
W	1105-001-336	Label, Steer (Green)	2
Y	1105-005-154	Butterfly "V" Pedal	2
AA	1115-003-405	Standard Brake Assembly (page 60)	1
AB	1115-005-500	Big Wheel Dual Sided Hydraulics (page 66)	1
AC	1210-201-251	Celcon Insert	1

[Return To Table of Contents](#)

Big Wheel Standard Brake Assembly

1115-003-405 Rev B (Reference Only)

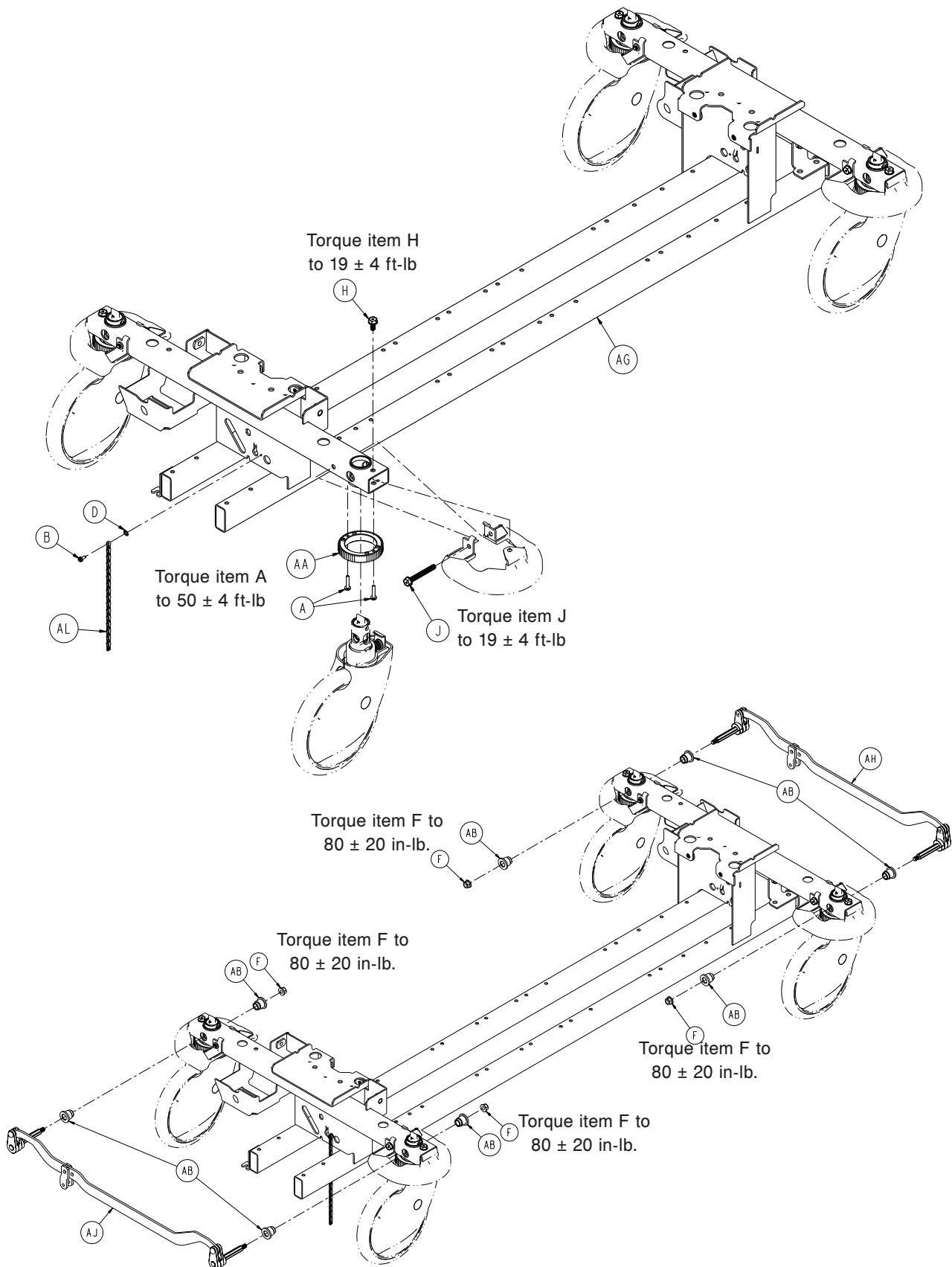

[Return To Table of Contents](#)

Big Wheel Standard Brake Assembly

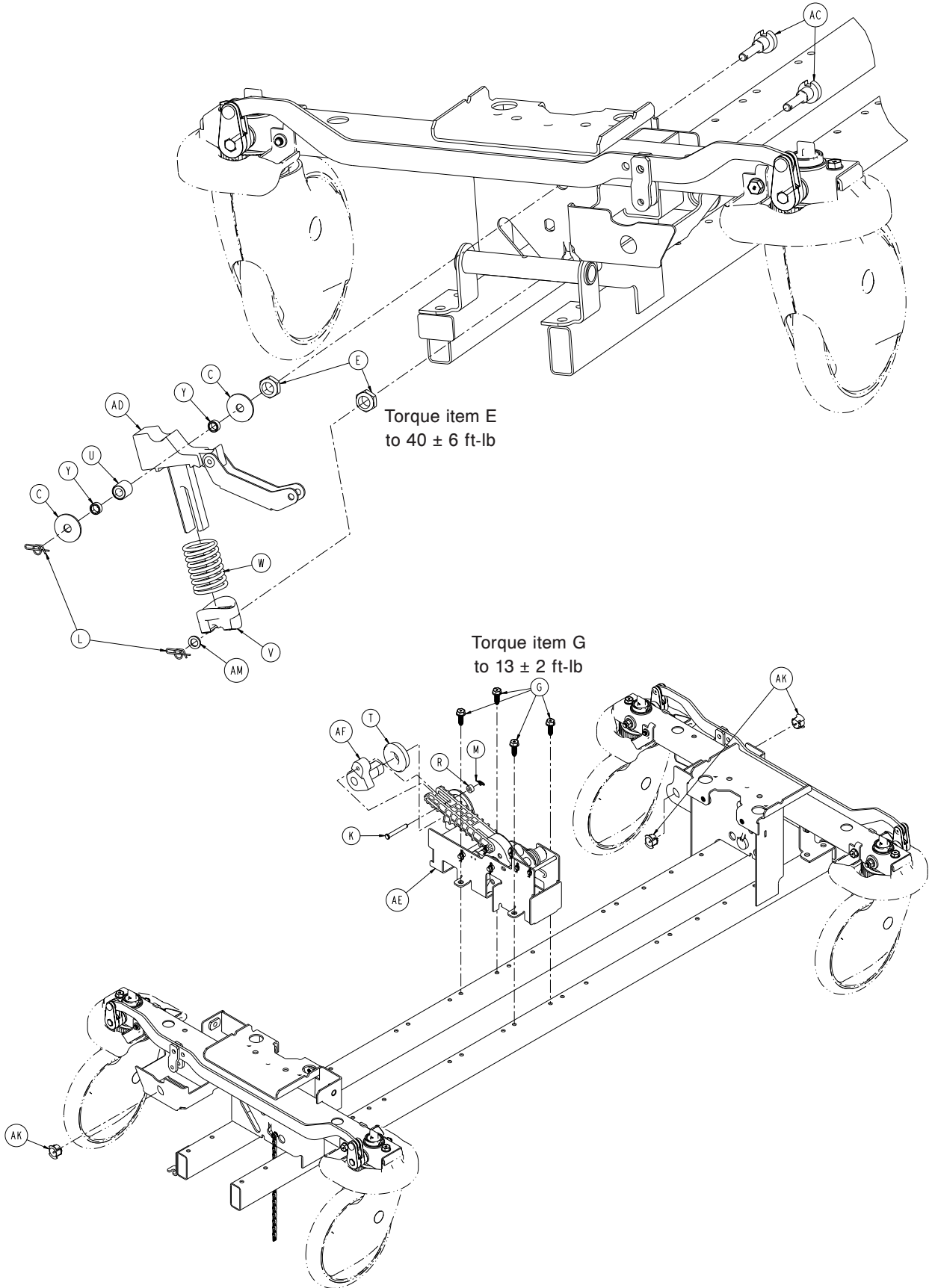

[Return To Table of Contents](#)

Big Wheel Standard Brake Assembly

Big Wheel Standard Brake Assembly - 1115-003-405 Rev B (Reference Only)

Item	Part No.	Part Name	Qty.
A	0003-147-000	Hex Washer Head Screw	8
B	0003-364-000	Hex Washer Head Truss Screw	1
C	0011-263-000	Washer	2
D	0013-018-000	External Tooth Lock Washer	1
E	0016-049-000	Nylock Hex Nut	2
F	0016-135-000	Nylock Flange Hex Nut	4
G	0023-288-000	Hex Washer Head Screw	4
H	0023-330-000	Hex Washer Head Screw	4
J	0023-331-000	Hex Washer Head Screw	4
K	0026-330-000	Clevis Pin	1
L	0027-019-000	Rue Ring Cotter	2
M	0027-020-000	Rue Ring Cotter	1
R	0052-015-000	Spacer	1
T	0081-330-000	Radial Bearing	1
U	0853-003-075	Timing Cam Bearing Assembly	1
V	0853-003-103	Timing Cam Spring Retainer	1
W	0853-003-104	Fifth Wheel Timing Cam Spring	1
Y	0853-003-031	Timing Cam Spacer	2
AA	0853-102-003	Caster Steer Lock Gear	4
AB	0853-102-004	Stepped Flange Bearing	8
AC	0853-203-230	Bearing Pivot Support	2
AD	1040-003-035	Big Wheel Timing Cam and Link Assy	1
AE	1115-006-201	Big Wheel Cam Bracket Assy (page 63)	1
AF	1040-006-231	Drive Arm	1
AG	1040-101-501	Base Weldment	1
AH	1040-103-010	Brake Link Assembly, Head End	1
AJ	1040-103-020	Brake Link Assembly, Foot End	1
AK	1210-201-251	Celcon Insert	3
AL	3001-200-052	Grounding Chain	1
AM	0014-003-000	Washer	1

Big Wheel Cam Bracket Assembly - 1115-006-201

Rev D

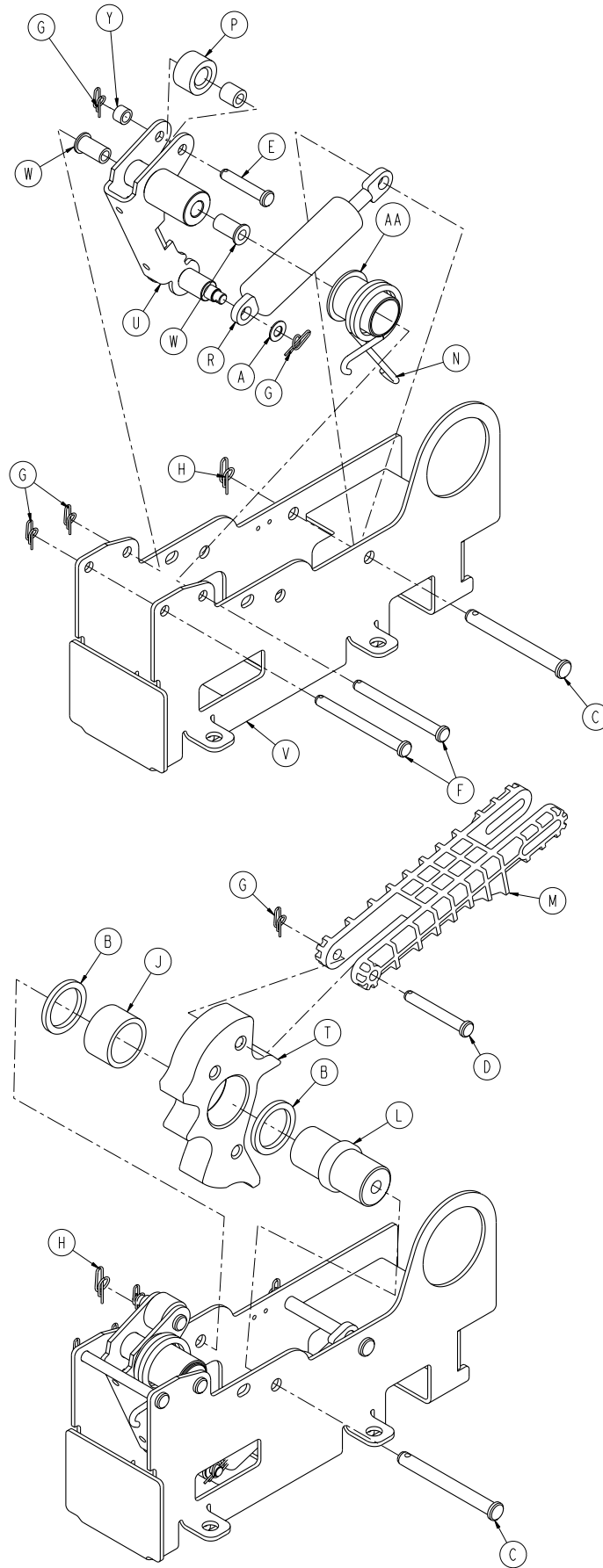

[Return To Table of Contents](#)

Big Wheel Cam Bracket Assembly - 1115-006-201

Item	Part No.	Part Name	Qty.
A	0014-004-000	Washer	1
B	0014-063-000	Washer	2
C	0026-262-000	Clevis Pin	2
D	0026-330-000	Clevis Pin	1
E	0026-349-000	Clevis Pin	1
F	0026-341-000	Clevis Pin	2
G	0027-020-000	Rue Ring Cotter	5
H	0027-025-000	Rue Ring Cotter	2
J	0081-400-000	Needle Bearing	1
L	1040-006-141	Cam Pivot	1
M	1040-006-144	Drive Link	1
N	1040-006-146	Torsion Spring	1
P	0081-305-000	Track Roller	1
R	1040-006-209	Dampener	1
T	1040-006-313	Lift Cam	1
U	1040-106-185	Dampener Arm Weldment	1
V	1115-006-221	Cam Bracket Weldment	1
W	0081-294-000	Flange Bearing	2
Y	1040-025-027	Link Spacer	1
AA	0081-345-000	Flange Bearing	1

Big Wheel Carriage Assembly

1040-215-201 Rev A (Reference Only)

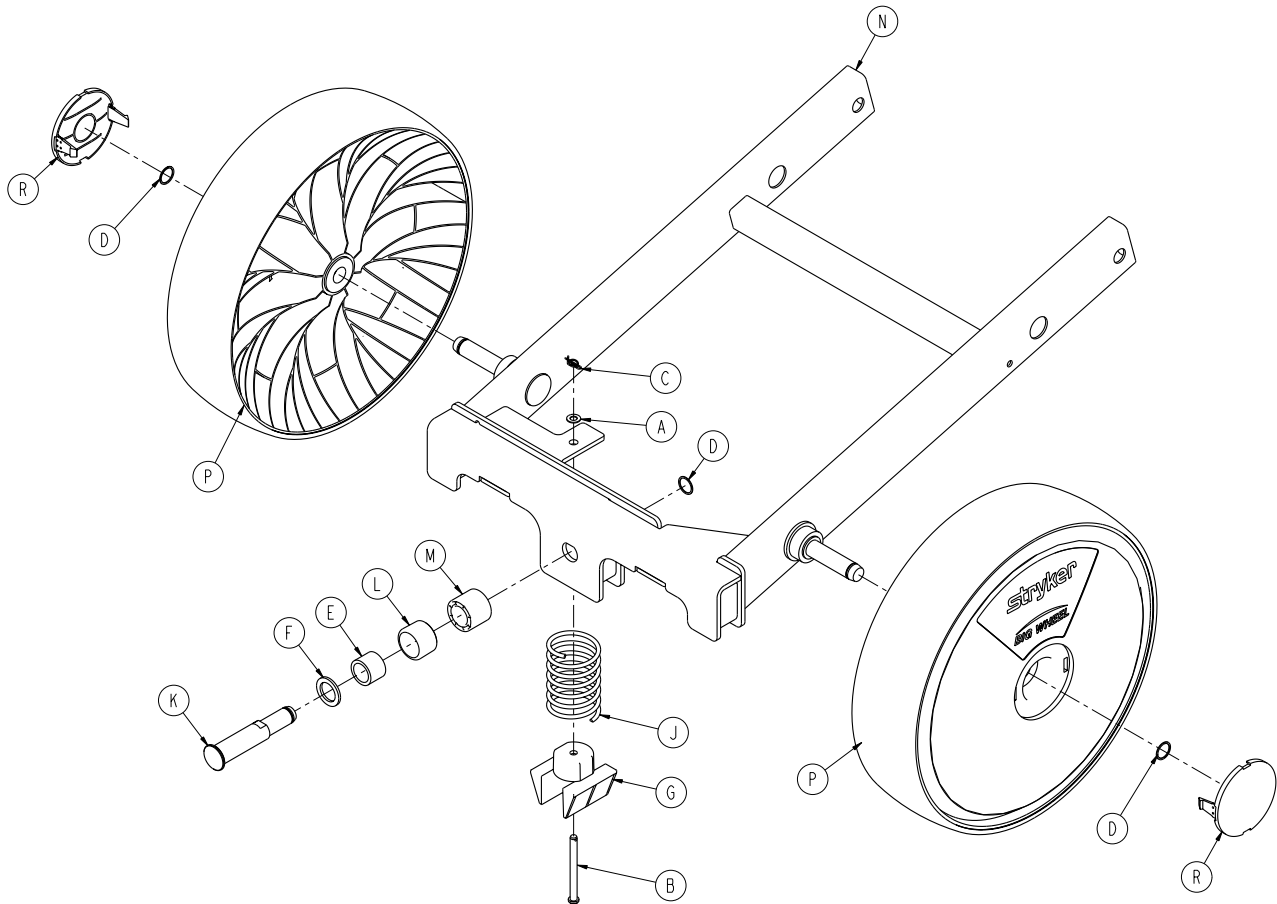

Item	Part No.	Part Name	Qty.
A	0014-004-000	Washer	1
B	0026-341-000	Clevis Pin	1
C	0027-020-000	Rue Ring Cotter	1
D	0028-330-000	Spiral Retaining Ring	3
E	0081-011-000	Needle Bearing	1
F	1040-015-038	Washer	1
G	1040-015-053	Carriage Spring Retainer	1
H	1040-015-078	Label, Big Wheel	2
J	1040-015-106	Carriage Return Spring	1
K	1040-020-122	Cam Follower Pivot Pin	1
L	1040-020-128	Lift Cam Roller	1
M	1040-020-129	Carriage Guide Roller	1
N	1040-215-110	Dual Sided Control Carriage Weldment	1
P	1115-015-070	Big Wheel Assembly	2
R	1115-015-073	Big Wheel Cap	2

[Return To Table of Contents](#)

Big Wheel Dual Sided Hydraulics Assembly

1115-005-500 Rev B (Reference Only)

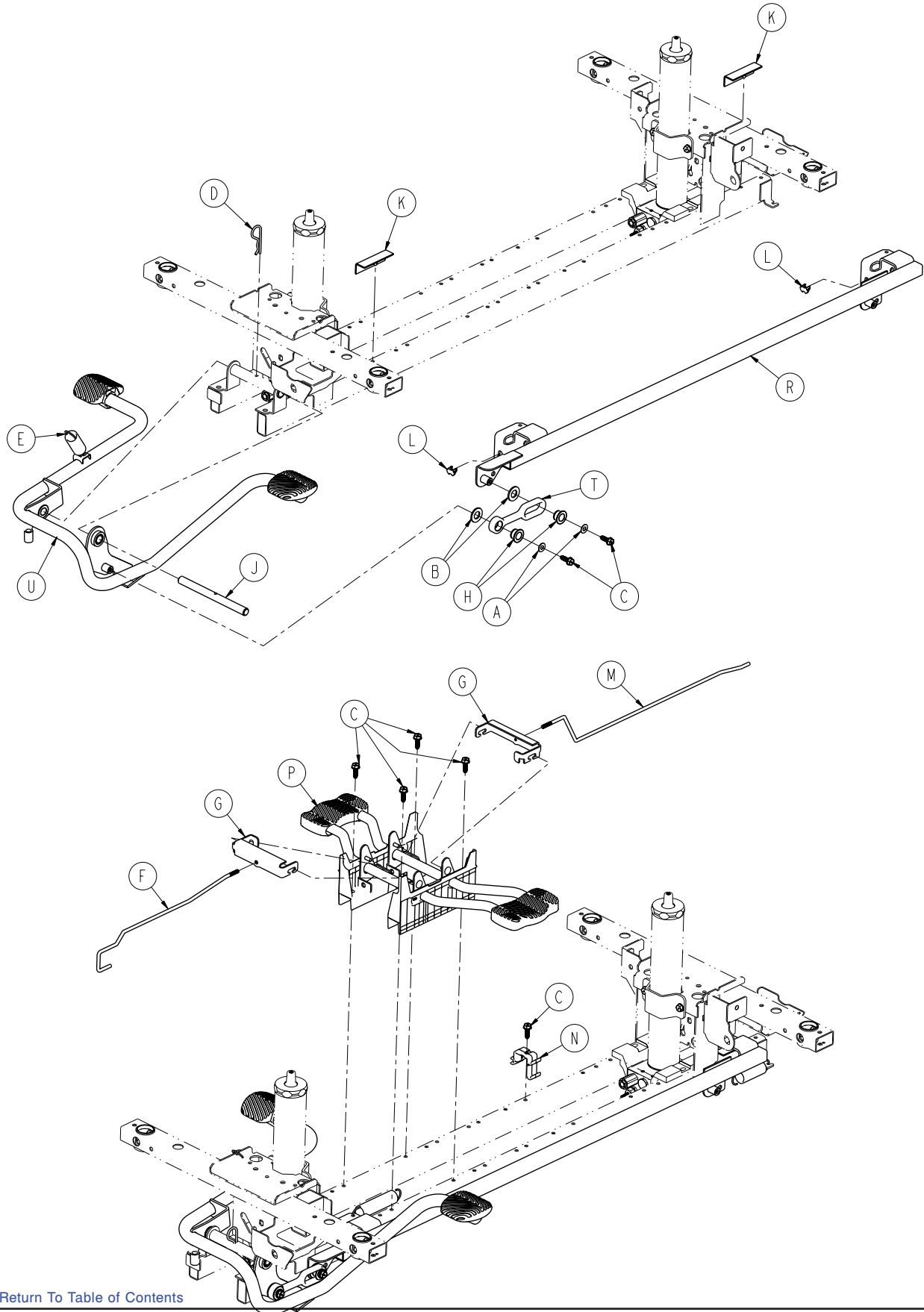

[Return To Table of Contents](#)

Big Wheel Dual Sided Hydraulics Assembly

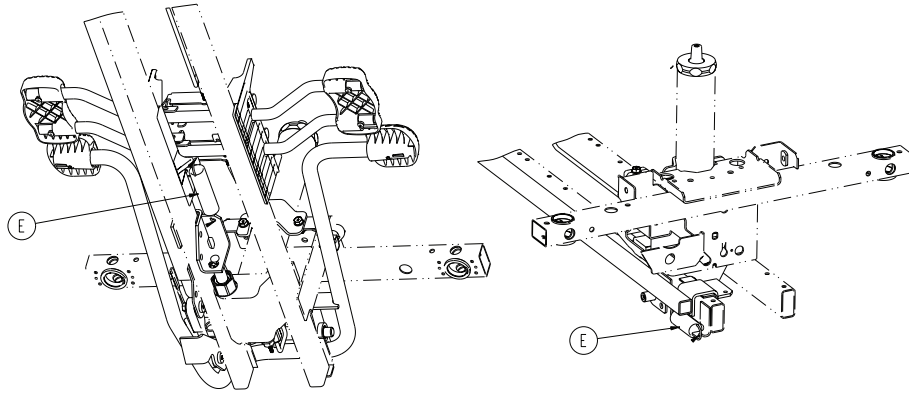

Big Wheel Dual Sided Hydraulics Assembly

Big Wheel Dual Sided Hydraulics Assembly - 1115-005-500 Rev B (Reference Only)

Item	Part No.	Part Name	Qty.
A	0011-023-000	Washer	2
B	0014-071-000	Washer	2
C	0023-288-000	Hex Washer Head Screw	7
D	0027-031-000	Hair Pin Cotter	1
E	0038-497-000	Extension Wire	3
F	0753-004-014	Release Rod, Head End	1
G	0753-004-132	Release Pedal Swivel	2
H	0753-005-044	Pump Pedal Bushing	2
J	0753-005-074	Pivot Pin	1
K	0753-005-088	Wear Strip	2
L	0753-005-089	Pump Ram Plug	2
M	1040-004-015	Release Rod, Foot End	1
N	1040-010-215	Release Rod Bracket	1
P	1115-004-201	Lowering Pedal Assembly (page 70)	1
R	1115-005-037	Pump Connecting Rod Weldment	1
T	1115-005-075	Pump Pedal Link	1
U	1115-005-285	Pump Pedal Assy, Head End (page 69)	1

Pump Pedal Assembly, Head End - 1115-005-285

Rev A

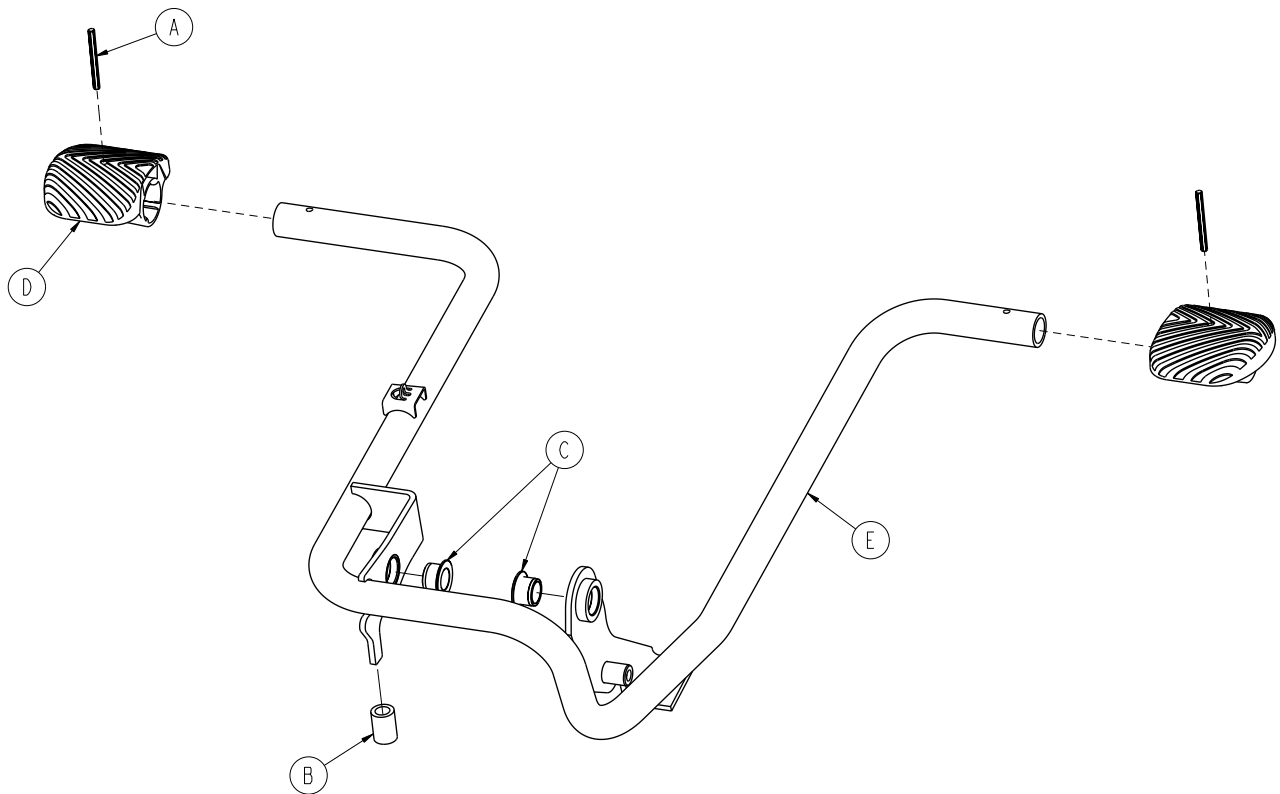

Item	Part No.	Part Name	Qty.
A	0026-343-000	Groove Pin	2
B	0715-001-140	Vinyl Tube	1
C	0753-005-044	Pump Pedal Bushing	2
D	1105-201-126	Pump Pedal Plastic	2
E	1115-005-180	Pump Pedal Weldment, Head End	1

[Return To Table of Contents](#)

Lowering Pedal Assembly - 1115-004-201

Rev A

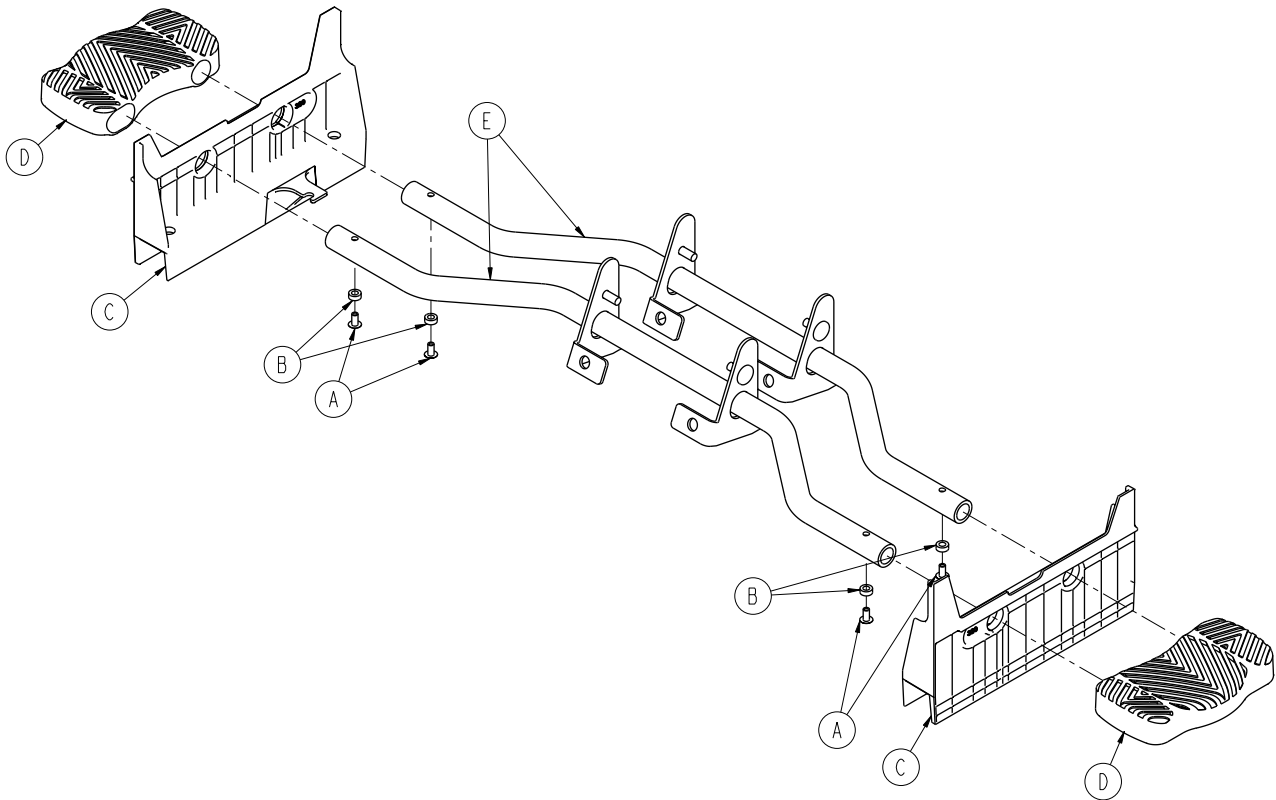

Item	Part No.	Part Name	Qty.
A	0025-079-000	Dome Head Rivet	4
B	0753-004-029	Release Pedal Standoff	4
C	0853-004-320	Release Pedal Support	2
D	1105-201-127	Short Uni-Pedal	2
E	1115-004-004	Release Pedal Weldment	2

Big Wheel Four-Sided Control Base Assembly

1115-025-205 Rev B (Reference Only)

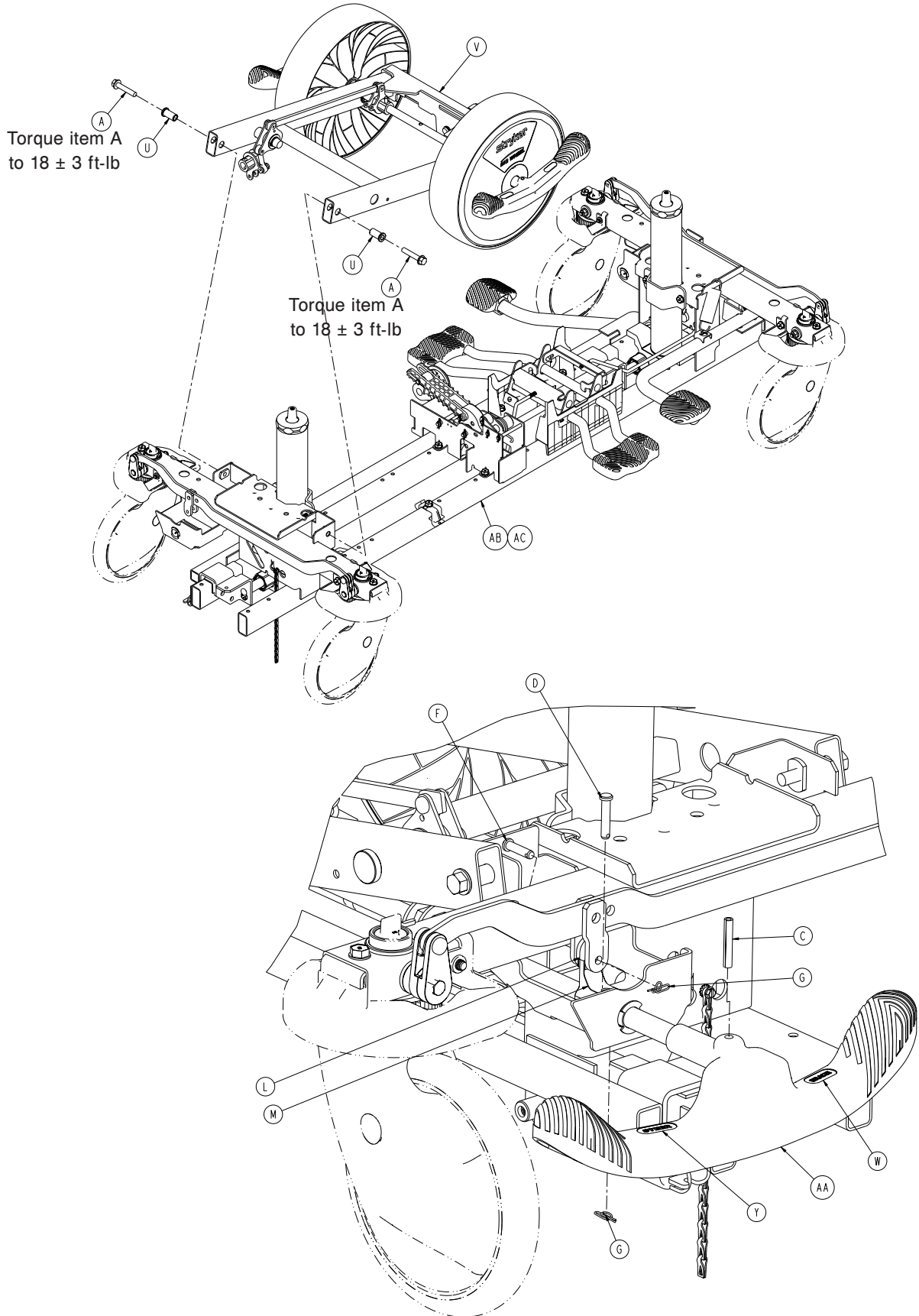

[Return To Table of Contents](#)

Big Wheel Four-Sided Control Base Assembly

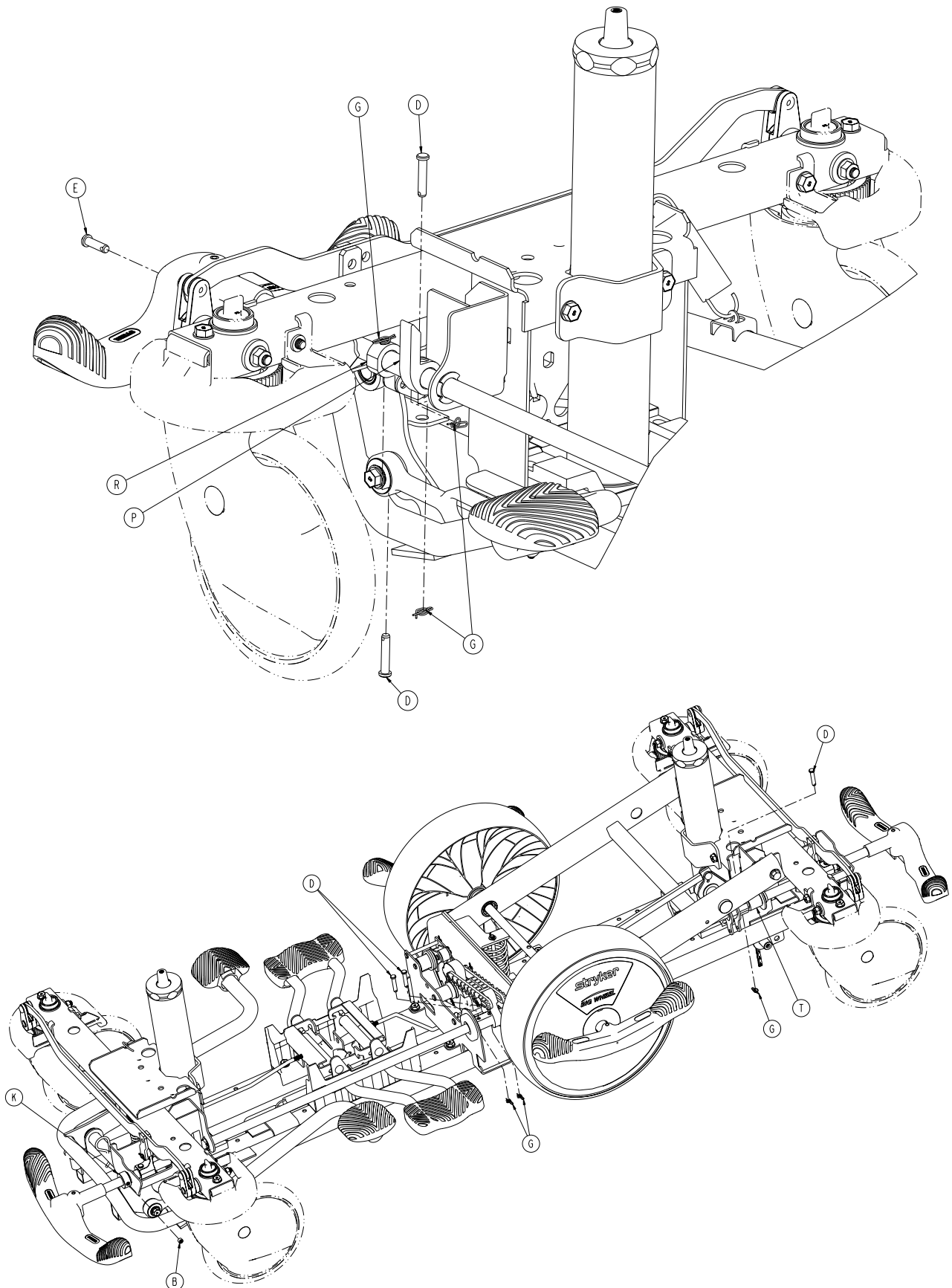

Big Wheel Four-Sided Control Base Assembly

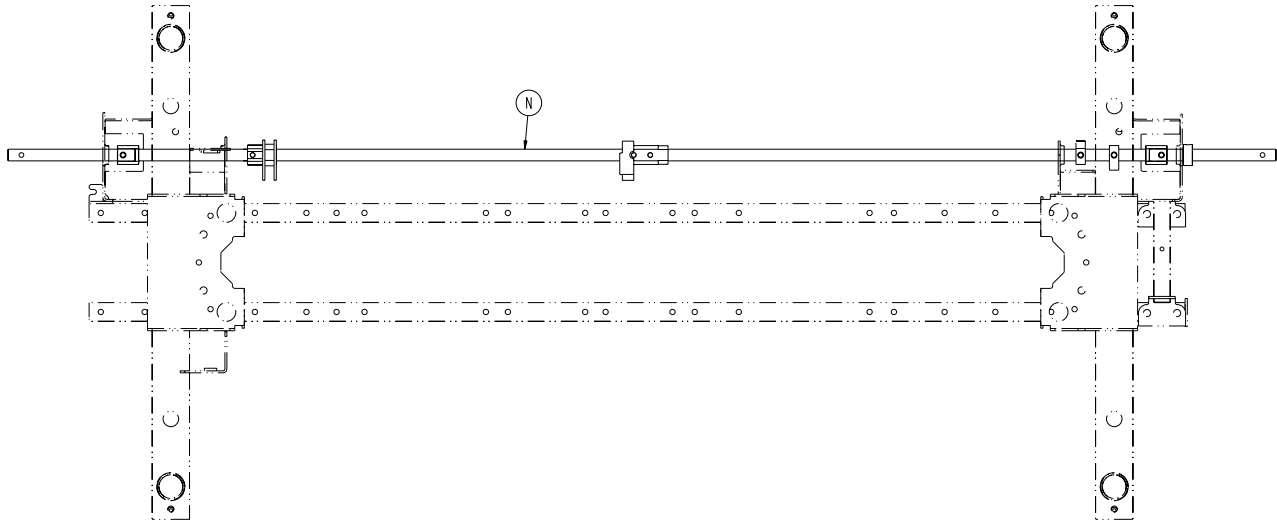

Big Wheel Four-Sided Control Base Assembly - 1115-025-205 Rev B (Reference Only)

Item	Part No.	Part Name	Qty.
A	0003-381-000	Hex Washer Head Truss Screw	2
B	0021-166-000	Set Screw	1
C	0026-067-000	Slotted Spring Pin	2
D	0026-251-000	Clevis Pin	7
E	0026-295-000	Clevis Pin	1
F	0026-393-000	Clevis Pin	2
G	0027-020-000	Rue Ring Cotter	10
K	0042-020-000	Collar	1
L	0853-003-064	Brake Rod Crank Cap	2
M	0853-203-011	Brake Activation Crank	2
N	1040-203-113	Brake Rod	1
P	1040-003-013	Timing Cam Hard Stop	1
R	1040-003-015	Big Wheel Timing Cam Crank Assembly	1
T	1040-025-026	Brake Rod Bushing	1
U	1040-115-007	Carriage Pivot Bushing	2
V	1040-225-201	Side Control Carriage Assembly (page 74)	1
W	1105-001-335	Label, Brake (Red)	2
Y	1105-001-336	Label, Steer (Green)	2
AA	1105-005-154	Butterfly "V" Pedal	2
AB	1115-003-405	Standard Brake Assembly (page 60)	1
AC	1115-005-500	Big Wheel Dual Sided Hydraulics (page 66)	1

[Return To Table of Contents](#)

Big Wheel Side Control Carriage Assembly

1040-225-201 Rev B (Reference Only)

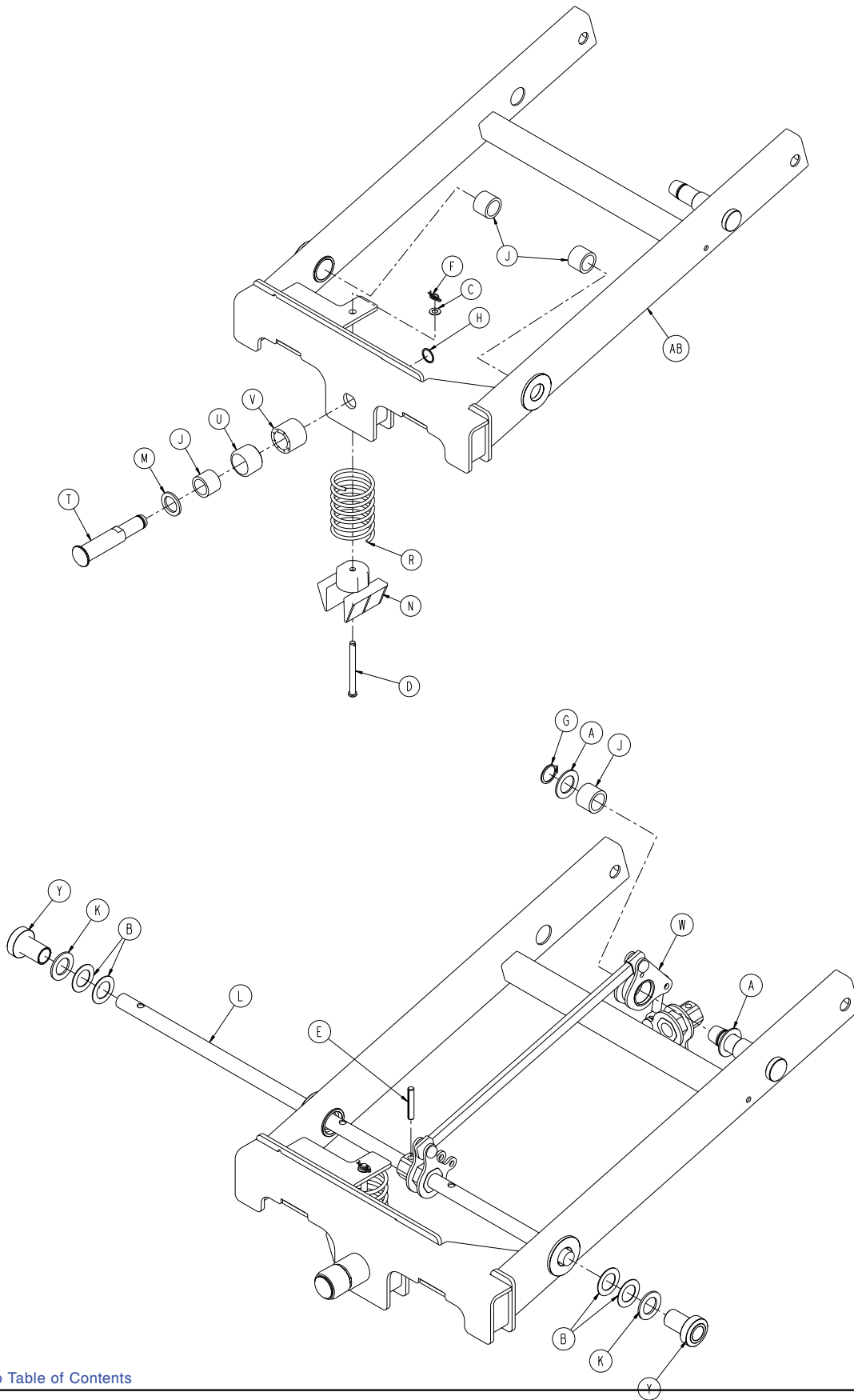

[Return To Table of Contents](#)

Big Wheel Side Control Carriage Assembly

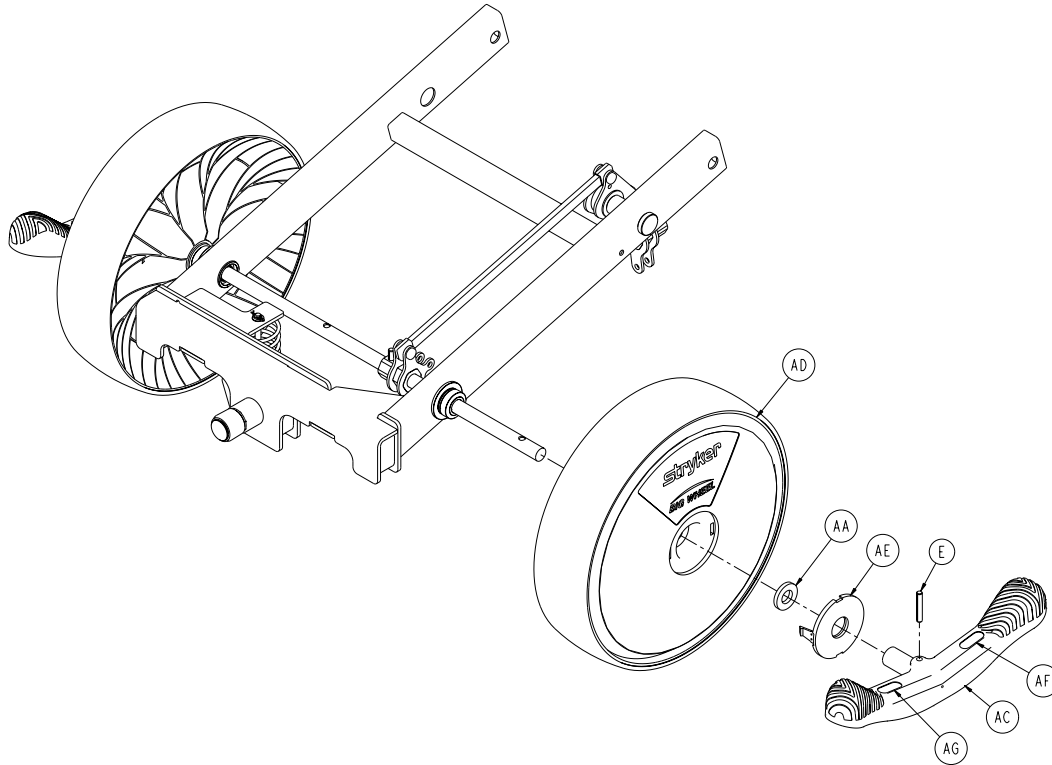

Big Wheel Side Control Carriage Assembly - 1040-225-201 Rev B (Reference Only)

Item	Part No.	Part Name	Qty.
A	0011-148-000	Washer	2
B	0011-525-000	Washer	4
C	0014-004-000	Washer	1
D	0026-341-000	Clevis Pin	1
E	0026-342-000	Grooved Pin	3
F	0027-020-000	Rue Ring Cotter	1
G	0028-166-000	External Retaining Ring	1
H	0028-330-000	Spiral Retaining Ring	1
J	0081-011-000	Needle Bearing	4
K	0081-175-000	Washer	2
L	0753-003-219	Side Control Brake Rod	1
M	1040-015-038	Washer	1
N	1040-015-053	Carriage Spring Retainer	1
P	1040-015-078	Label, Big Wheel	2
R	1040-015-106	Carriage Return Spring	1
T	1040-020-122	Cam Follower Pivot Pin	1
U	1040-020-128	Lift Cam Roller	1
V	1040-020-129	Carriage Guide Roller	1
W	1040-125-010	Side Control Linkage Assy (page 76)	1
Y	1040-025-014	Side Control Wheel Spacer	2
AA	1040-025-017	Side Control Pedal Spacer	2
AB	1040-225-110	Four-Sided Control Carriage Weldment	1
AC	1115-005-155	Butterfly "V" Pedal	2
AD	1115-015-070	Big Wheel Assembly	2
AE	1115-015-074	Big Wheel Side Control Cap	2
AF	1105-001-335	Label, Brake (Red)	2
AG	1105-001-336	Label, Steer (Green)	2

[Return To Table of Contents](#)

Big Wheel Side Control Linkage Assembly - 1040-125-010

Rev B

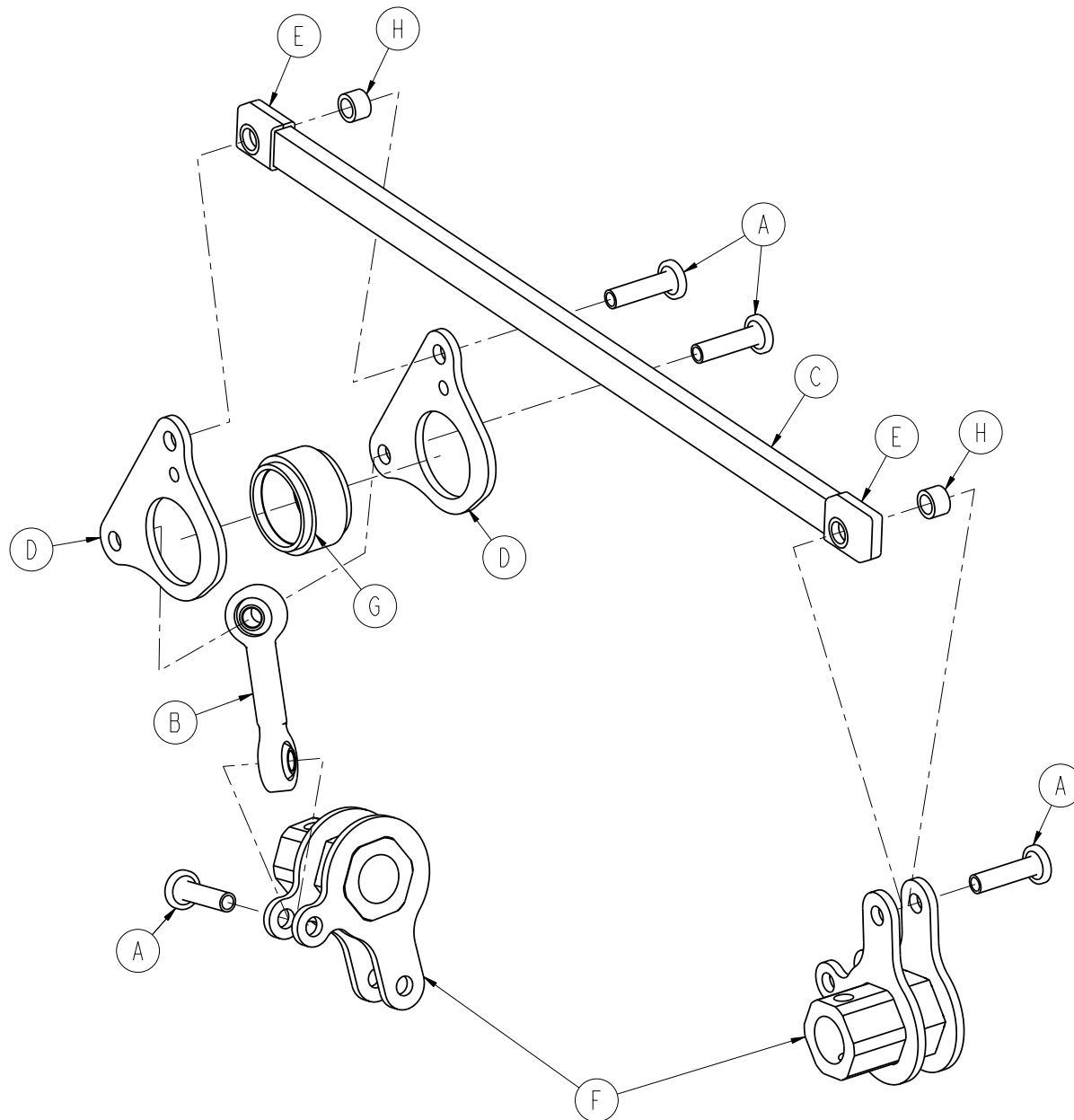

Item	Part No.	Part Name	Qty.
A	0753-003-098*	Flat Head Semi-Tubular Rivet	4
B	0753-003-117*	Rod End Link	1
C	1040-025-011*	Main Link	1
D	1040-025-013*	Toggle Pivot Plate	2
E	1040-025-016*	Main Link Cover	2
F	1040-025-020*	Yoke Weldment	2
G	1040-125-018*	Toggle Pivot Spacer	1
H	1040-025-027*	Link Spacer	2

* Shown for reference only. Individual part components are not available for sale.

Base Labeling Assembly, Standard Brakes

0747-010-100 Rev A (Reference Only)

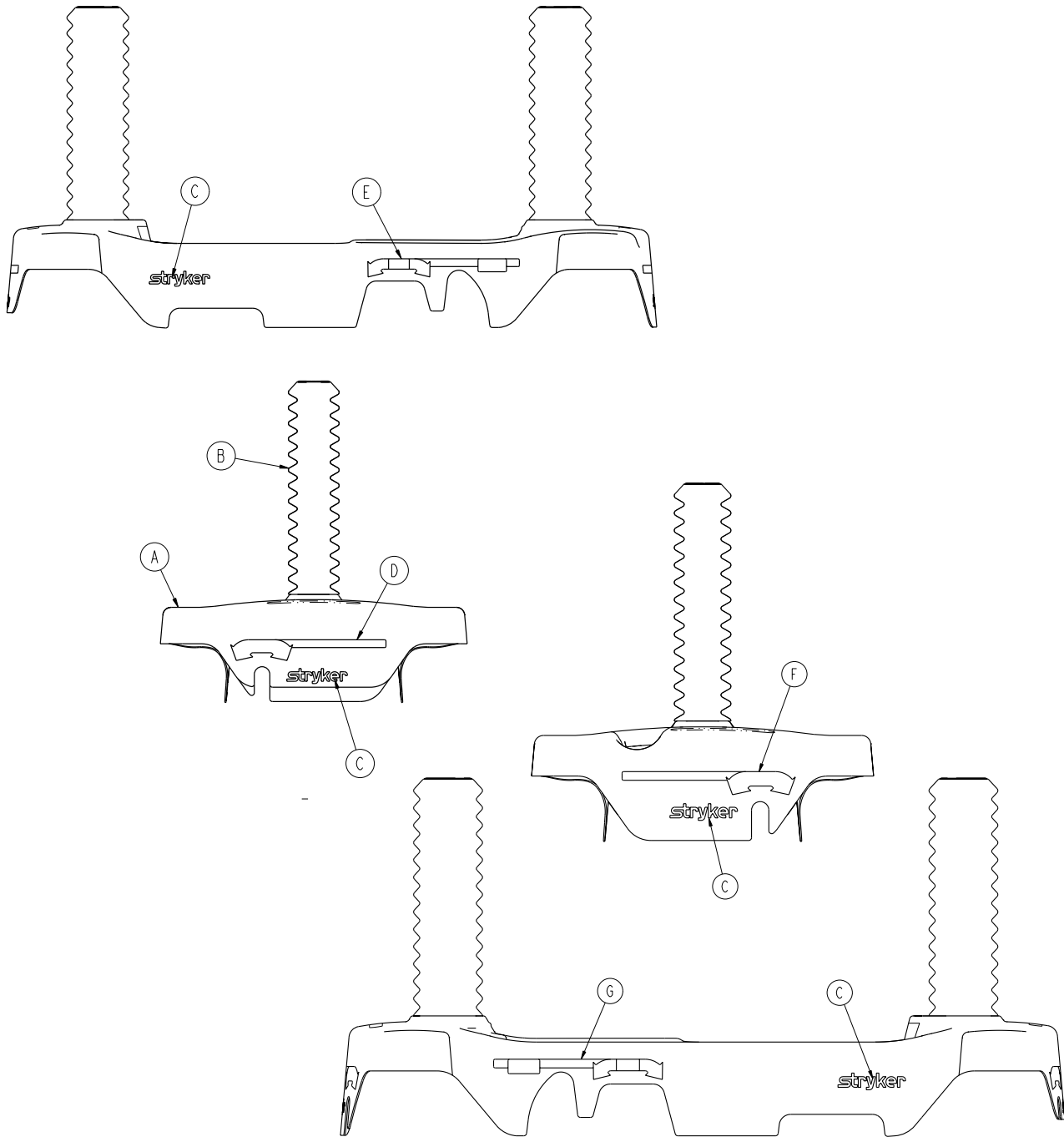

Item	Part No.	Part Name	Qty.
A	0747-001-035	Standard Hood	1
B	0747-010-134	Dipped Bellows	2
C	0946-201-060	Label, Stryker Logo	4
D	0753-010-351	Label, Brake/Steer, Foot End	1
E	0853-010-355	Label, Lift/Lower, Left	1
F	0753-010-370	Label, Brake/Steer, Head End	1
G	0853-010-354	Label, Lift/Lower, Right	1

[Return To Table of Contents](#)

Base Labeling Assembly, Four-Sided Brakes

0747-010-200 Rev A (Reference Only)

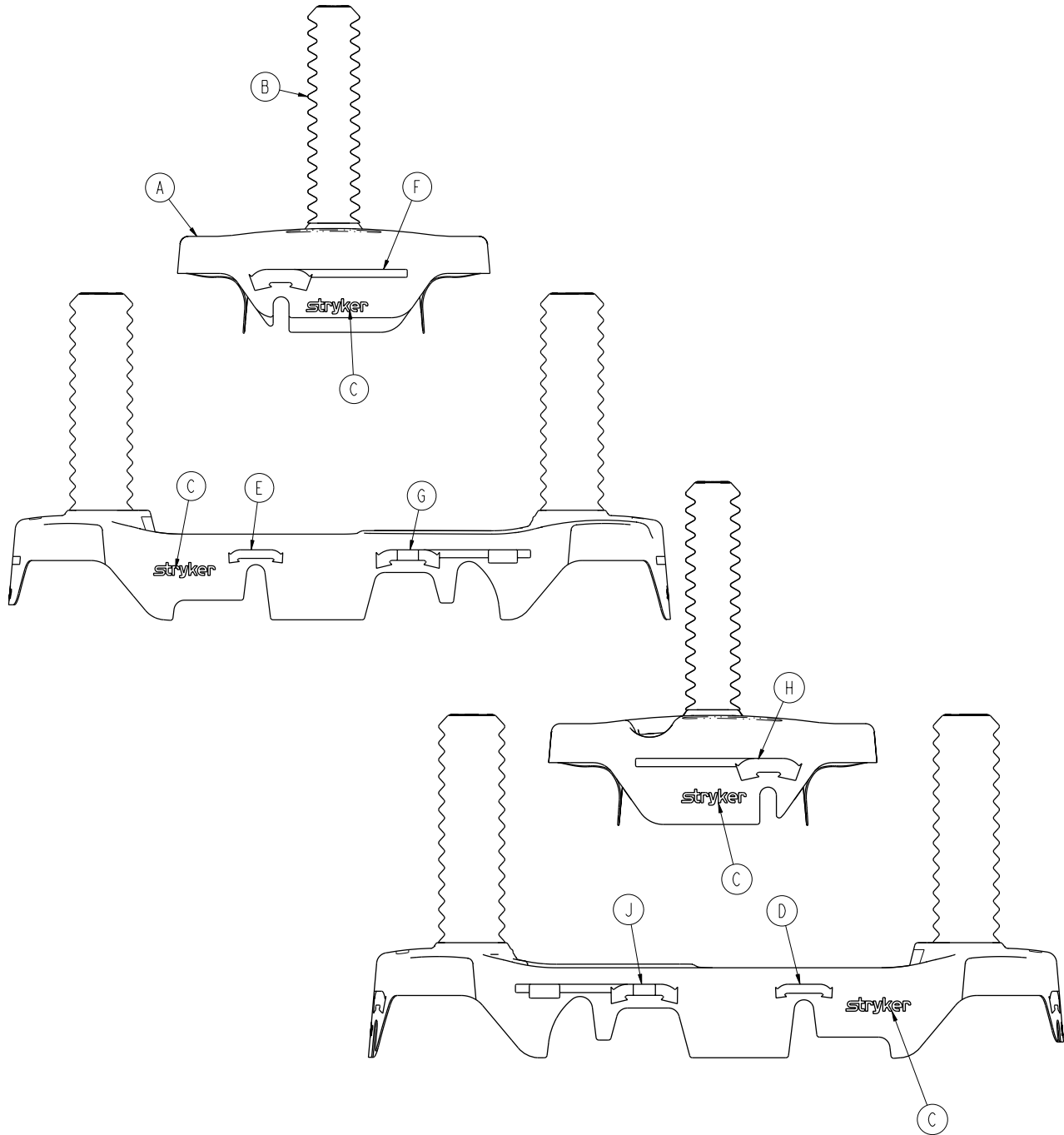

Item	Part No.	Part Name	Qty.
A	0747-010-034	Hood, Four-Sided Brakes	1
B	0747-010-134	Dipped Bellows	2
C	0946-201-060	Label, Stryker Logo	4
D	0853-010-018	Label, Brake/Steer, Right	1
E	0853-010-019	Label, Brake/Steer, Left	1
F	0753-010-351	Label, Brake/Steer, Foot End	1
G	0853-010-355	Label, Lift/Lower, Left	1
H	0753-010-370	Label, Brake/Steer, Head End	1
J	0853-010-354	Label, Lift/Lower, Right	1

[Return To Table of Contents](#)

Base Labeling Assembly - Big Wheel Base

1037-010-100 Rev A (Reference Only)

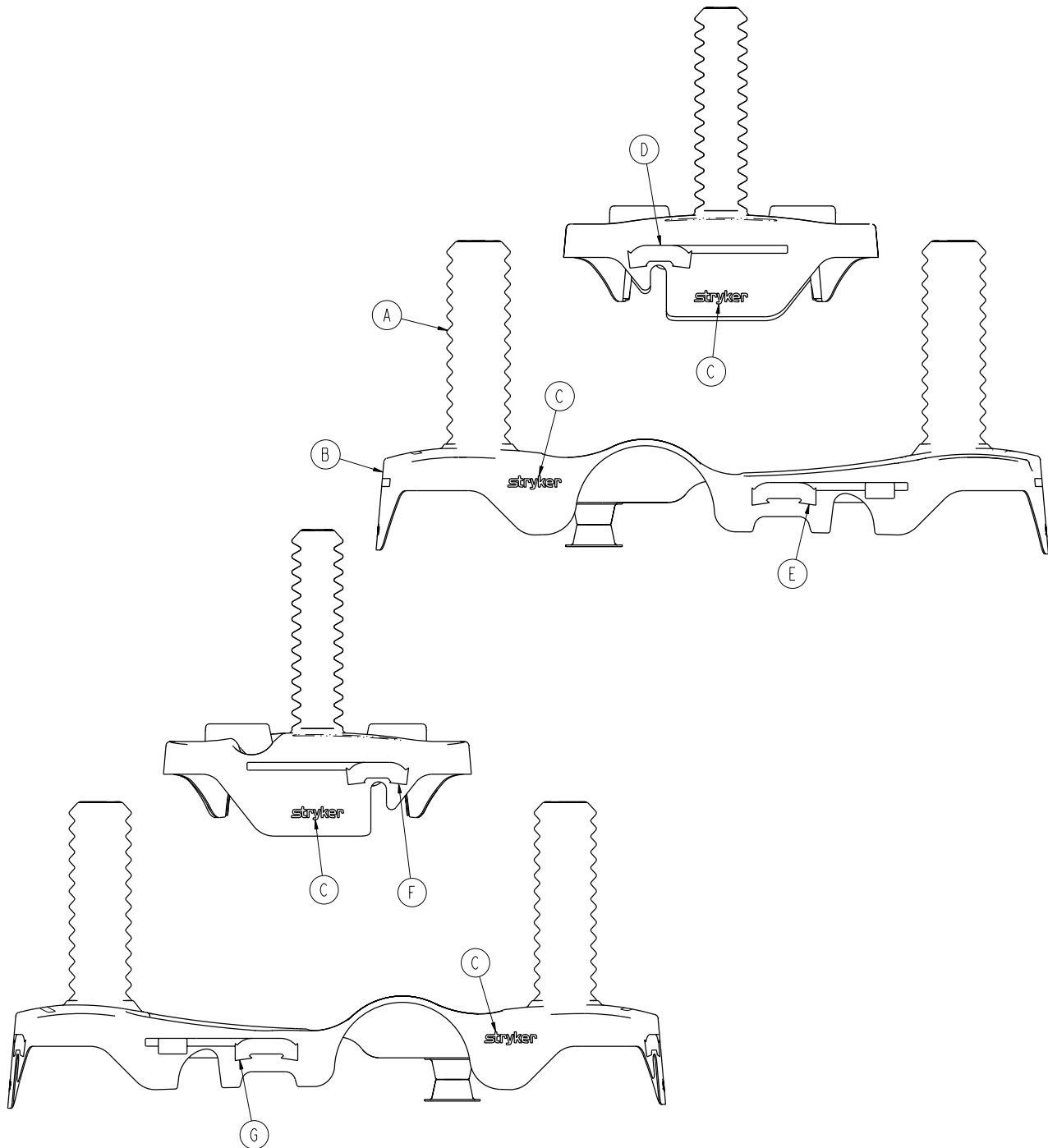

Item	Part No.	Part Name	Qty.
A	0747-010-134	Dipped Bellows	2
B	1037-001-035	Big Wheel Hood	1
C	0946-201-060	Label, Stryker Logo	4
D	0753-010-351	Label, Brake/Steer, Foot End	1
E	0853-010-355	Label, Lift/Lower, Left	1
F	0753-010-370	Label, Brake/Steer, Head End	1
G	0853-010-354	Label, Lift/Lower, Right	1

[Return To Table of Contents](#)

Litter Assembly

1037-030-010 Rev A (Reference Only)

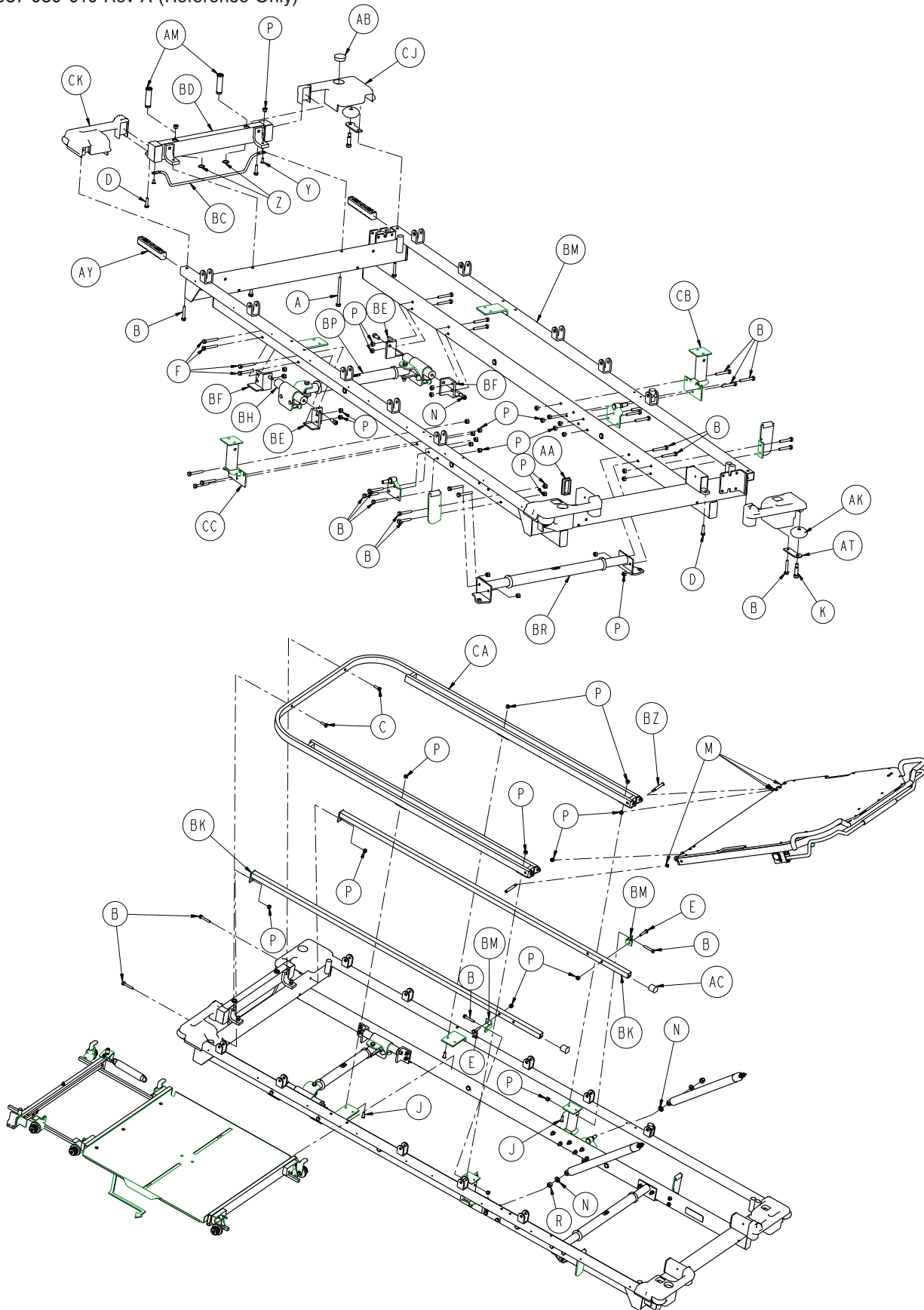

[Return To Table of Contents](#)

Litter Assembly

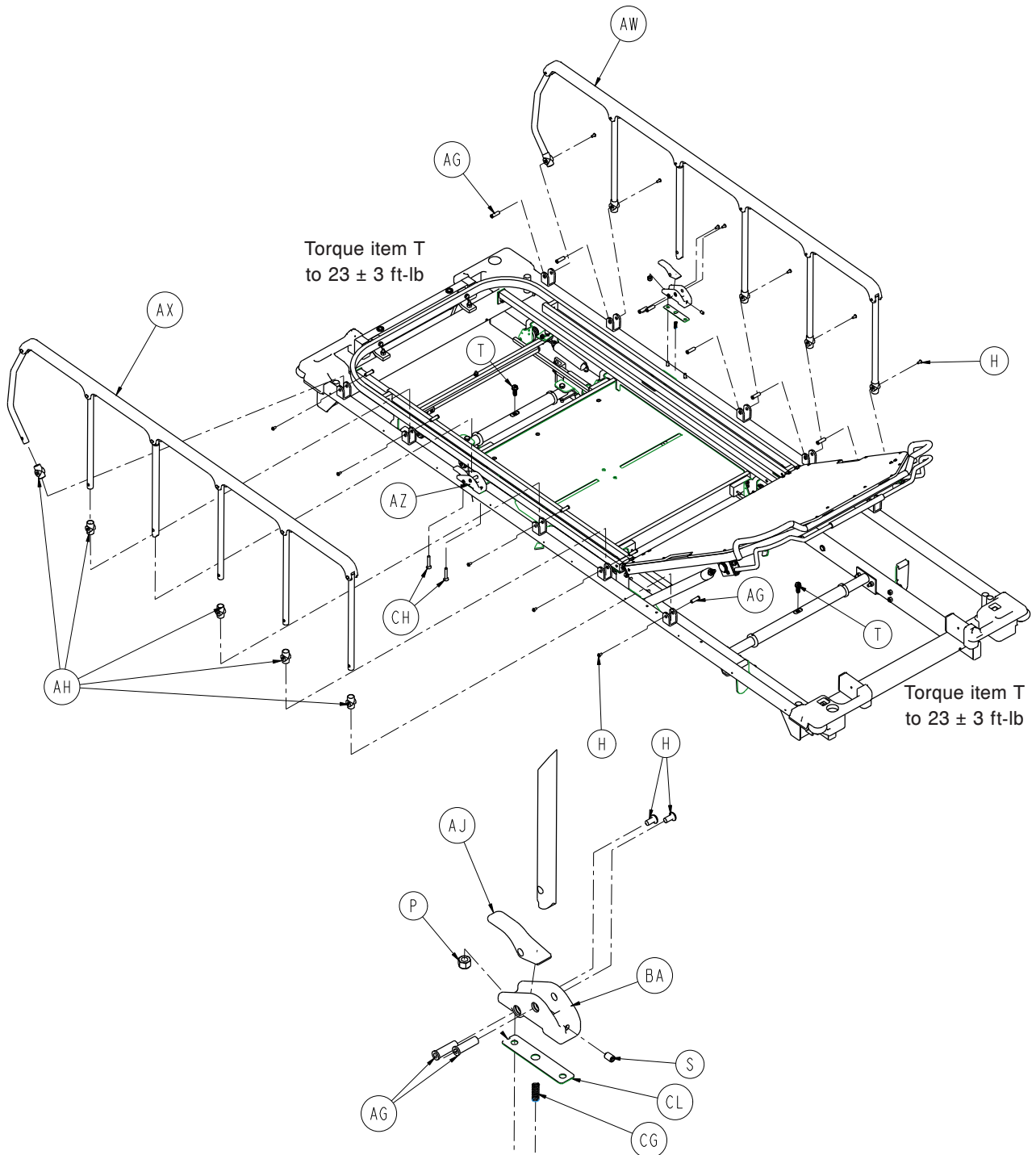

[Return To Table of Contents](#)

Litter Assembly

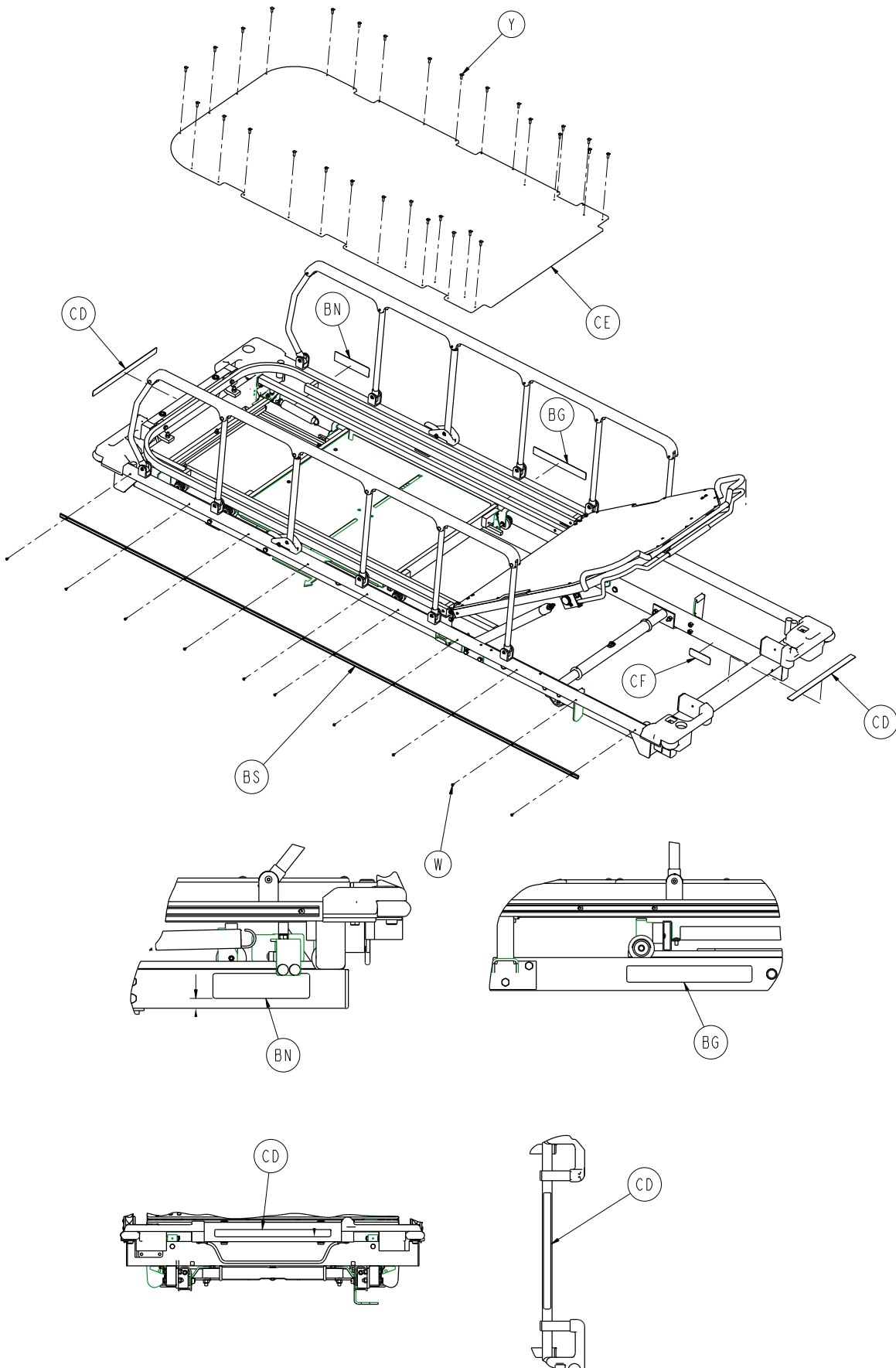

[Return To Table of Contents](#)

Litter Assembly

Litter Assembly - 1037-030-010 Rev A (Reference Only)

Item	Part No.	Part Name	Qty.
A	0003-035-000	Hex Head Cap Screw	2
B	0003-047-000	Hex Head Cap Screw	28
C	0003-050-000	Hex Head Cap Screw	2
D	0003-054-000	Hex Head Cap Screw	4
E	0003-074-000	Hex Head Cap Screw	2
F	0003-078-000	Hex Head Cap Screw	8
G	0004-021-000	Socket Head Cap Screw	4
H	0004-515-000	Button Head Cap Screw	14
J	0004-161-000	Button Head Cap Screw	4
K	0008-024-000	Socket Head Set Screw	4
M	0014-003-000	Washer	4
N	0014-021-000	Washer	4
P	0016-028-000	Hex Nut	44
R	0016-035-000	Nylock Hex Nut	2
S	0021-104-000	Set Screw	2
T	0023-288-000	Hex Washer Head Screw	2
W	0025-038-000	Rivet	20
Y	0025-099-000	Rivet	32
Z	0028-023-000	External Retaining Ring	2
AA	0037-049-000	Rectangular Hole Plug	8
AB	0037-059-000	Heyco Hole Plug	1
AC	0037-063-000	Hole Plug	2
AG	0721-026-066	Pivot Screw	14
AH	0721-026-069	Upright Sleeve	10
AJ	0721-026-074	Plated Lock Handle	2
AK	0721-032-049	Bumper Roller	4
AM	0721-040-026	Footboard Receptacle	2
AT	1010-001-017	Roller Plate	4
AW	1010-026-017	Siderail Assembly, Right (page 88)	1
AX	1010-026-019	Siderail Assembly, Left (page 87)	1
AY	1010-026-069	Lock Support	2
AZ	0742-026-086	Lock Housing, Right	1
BA	0742-026-087	Lock Housing, Left	1
BC	1010-032-092	Foley Bag Rack	1
BD	1037-001-040	Footboard Support Assembly	1
BE	1037-001-042	Roller Support Assembly, Left	2
BF	1037-001-043	Roller Support Assembly, Right	2
BG	1020-001-053	Label, Euro Centering	1
BH	1020-001-059	Trend Roller Bar	2
BJ	1037-001-061	Litter Frame Assembly	1
BK	1037-022-023	Guide Tube Assembly	2
BM	1037-022-026	Adjustment Bracket	2
BN	1020-022-028	Squeeze Label	1
BP	1037-024-002	Litter Support Assembly, Foot End (page 86)	1

Litter Assembly

Litter Assembly - 1037-030-010 Rev A (Reference Only) (Continued)

BR	1037-024-003	Litter Support Assembly, Head End (page 85)	1
BS	1020-026-021	Bumper Channel	2
BZ	1020-032-019	Pivot Bolt	2
CA	1037-032-025	Footsection Weldment	1
CB	1037-032-031	Litter Riser, Right	1
CC	1037-032-032	Litter Riser, Left	1
CD	1020-091-052	Centering Euro-Label	2
CE	1020-032-026	Foot Section Skin	1
CF	1210-800-008	Patent Label	1
CG	0038-220-000	Compression Spring	2
CH	0001-096-000	Flat Countersunk Head Machine Screw	4
CJ	1010-001-013	Foot End Cover, Right	1
CK	1010-001-014	Foot End Cover, Left	1
CL	0747-026-103	Retainer Spring	2

Litter Support Assembly, Head End - 1037-024-003

Rev A

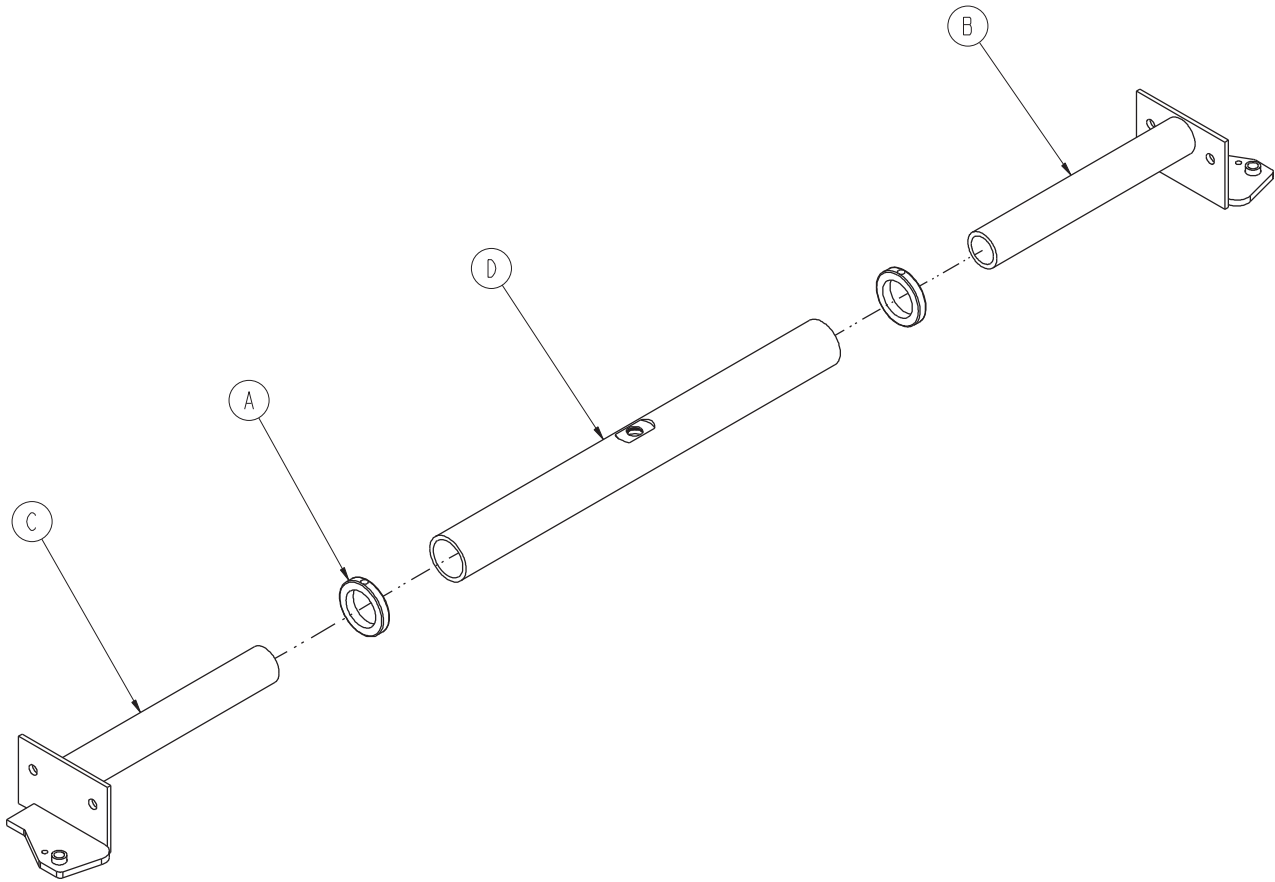

Item	Part No.	Part Name	Qty.
A	0938-001-401	Collar	2
B	1020-024-004	Jack Support Weldment, Left	1
C	1020-024-005	Jack Support Weldment, Right	1
D	1037-010-030	Support Tube	1

[Return To Table of Contents](#)

Litter Support Assembly, Foot End - 1037-024-002

Rev A

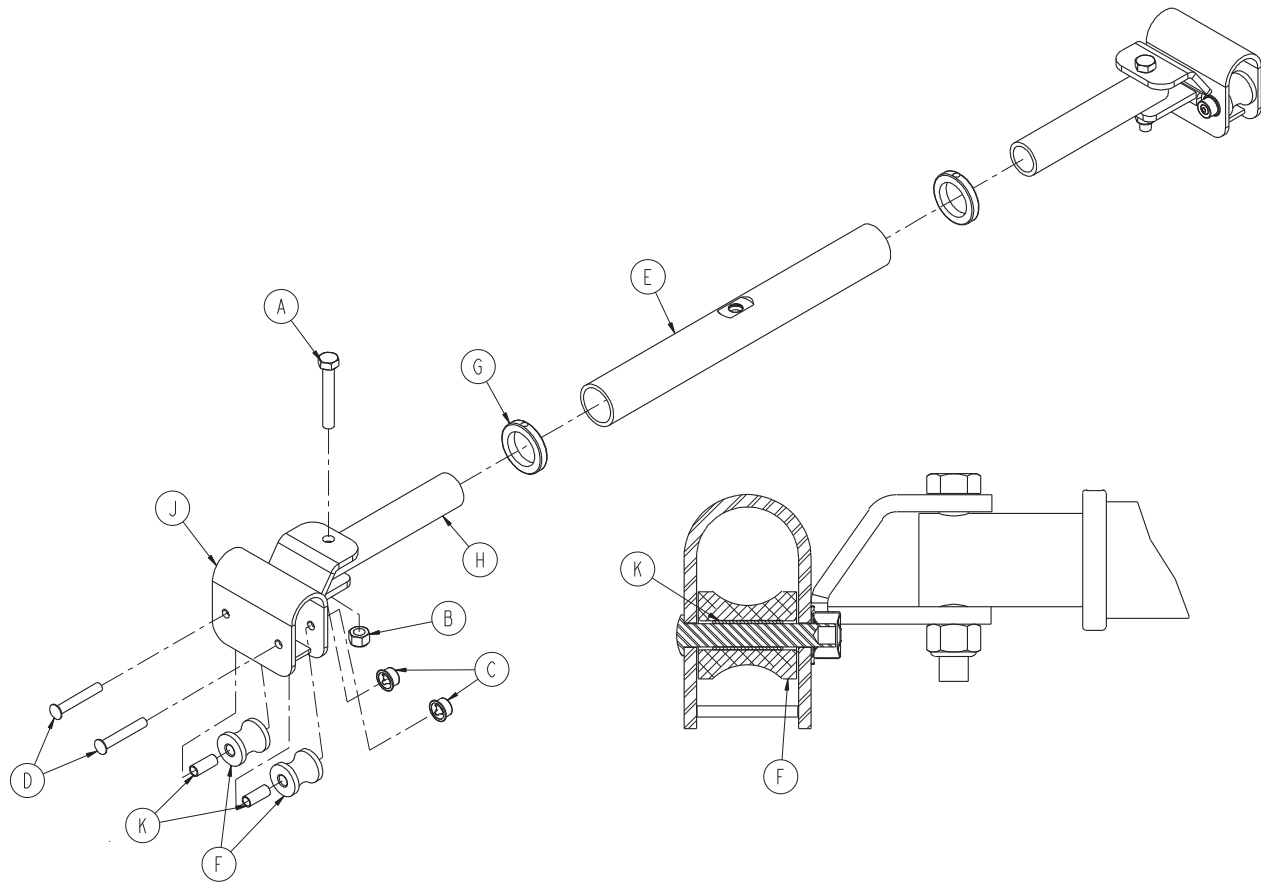

Item	Part No.	Part Name	Qty.
A	0003-040-000	Hex Head Cap Screw	2
B	0016-036-000	Nylock Hex Nut	2
C	0017-003-000	Cap Nut	4
D	0025-053-000	Rivet	4
E	1037-010-029	Support Tube	1
F	0938-001-292	Support Tube Roller	4
G	0938-001-401	Collar	2
H	1010-032-064	Carrier Tube	2
J	1037-001-048	Support Tube Assembly, Foot End	2
K	0081-063-000	Bearing	4

Siderail, Left - 1010-026-017

Rev D

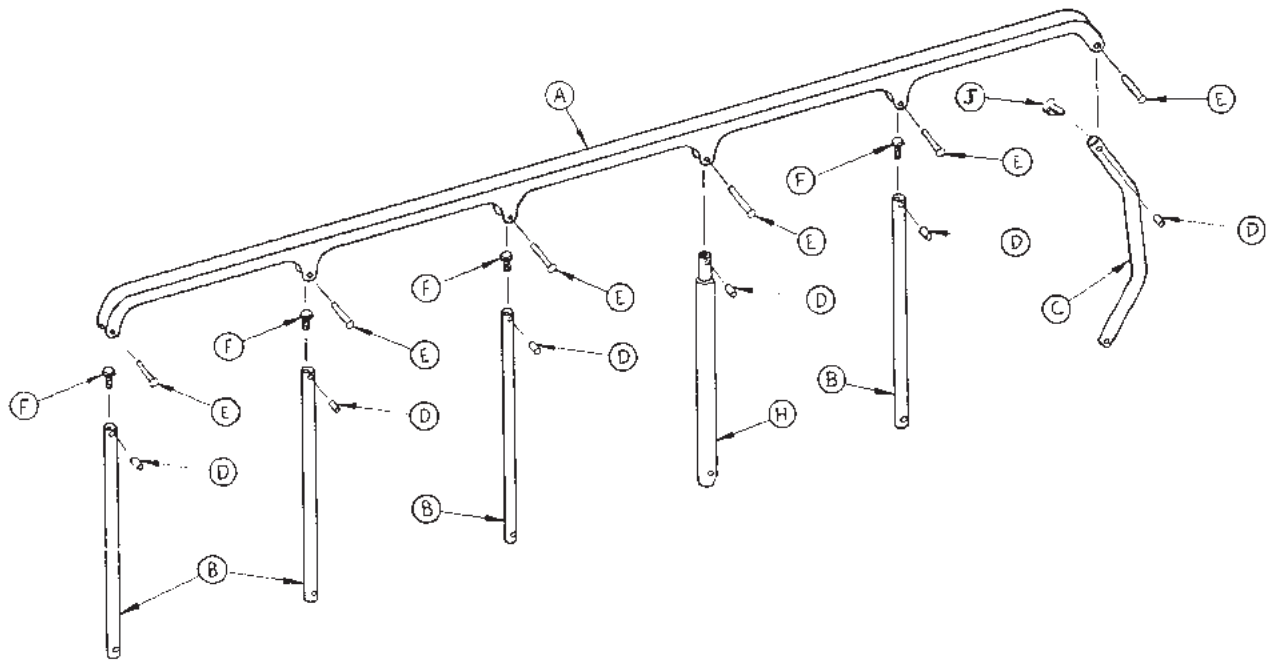

Item	Part No.	Part Name	Qty.
A	1010-026-015	Top Rail	1
B	1010-026-083	Upright	4
C	1010-026-084	Upright, Bent	1
D	1010-026-082	Sleeve Bearing	6
E	0025-106-000	Semi-Tubular Rivet	6
F	1010-026-010	Round Hole Plug	4
H	1010-026-085	Latch Upright	1
J	1010-026-012	Bent Spindle Rest	1

[Return To Table of Contents](#)

Siderail, Right - 1010-026-019

Rev D

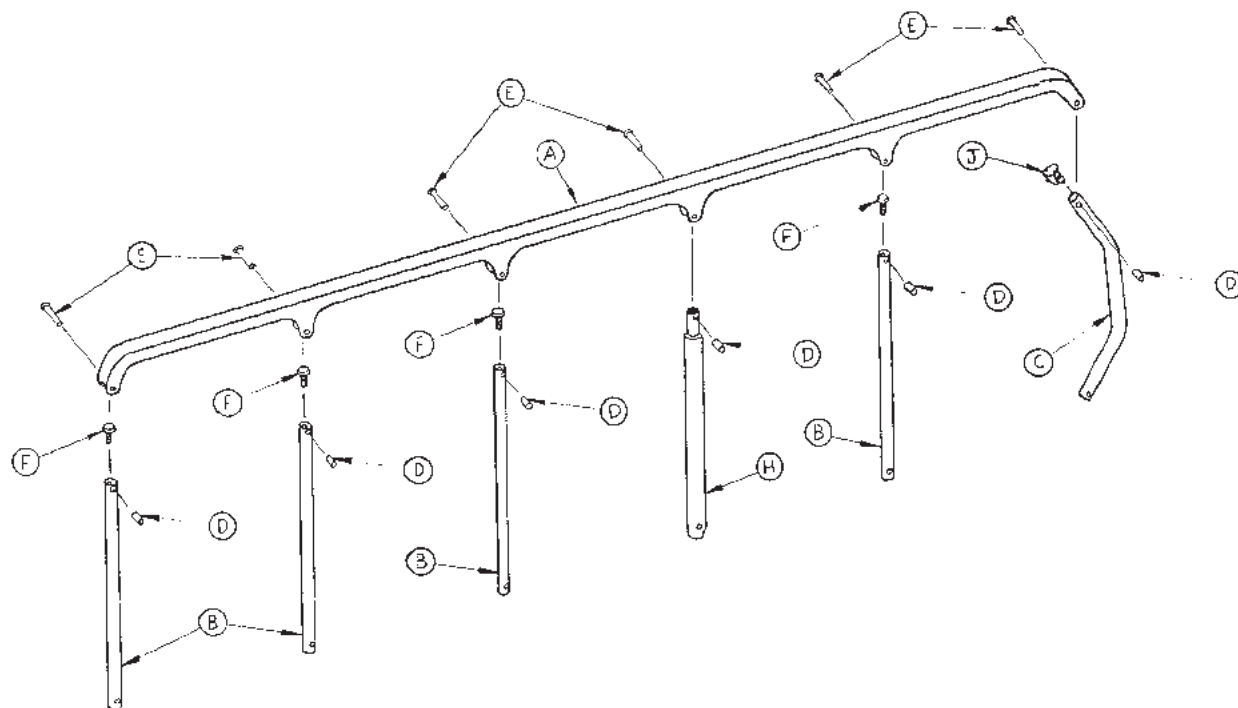

Item	Part No.	Part Name	Qty.
A	1010-026-015	Top Rail	1
B	1010-026-083	Upright	4
C	1010-026-084	Upright, Bent	1
D	1010-026-082	Sleeve Bearing	6
E	0025-106-000	Semi-Tubular Rivet	6
F	1010-026-010	Round Hole Plug	4
H	1010-026-085	Latch Upright	1
J	1010-026-012	Bent Spindles Rest	1

Pneumatic Fowler to Litter Assembly

1037-031-011 Rev A (Reference Only)

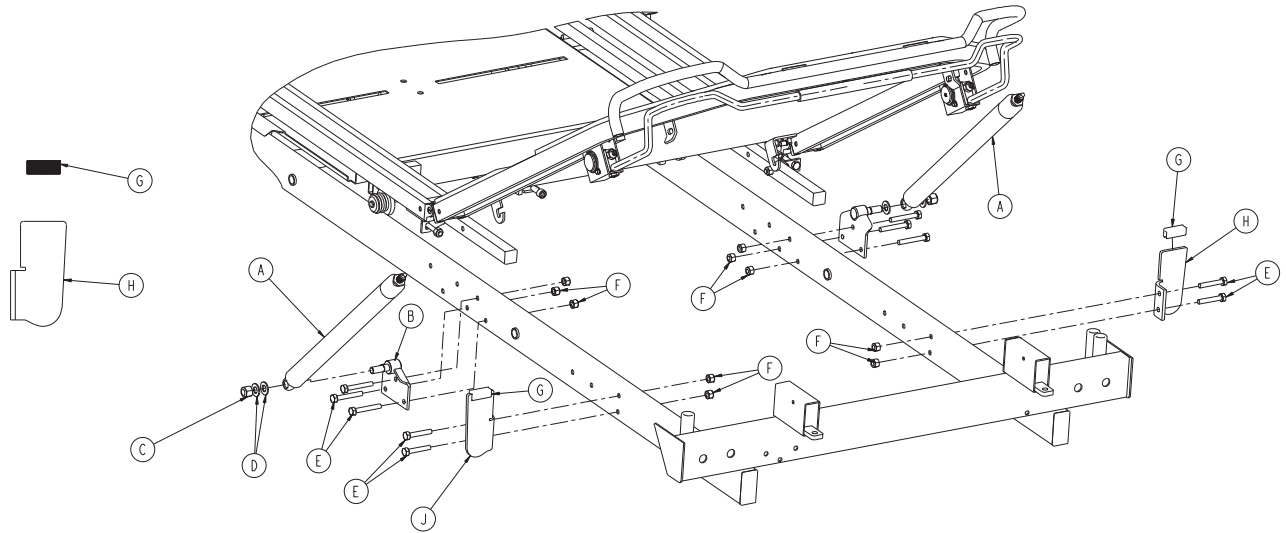

Item	Part No.	Part Name	Qty.
A	1010-031-078	Gas Cylinder	2
B	1037-031-025	Cylinder Mount	2
C	0016-035-000	Nylon Hex Nut	2
D	0014-021-000	Flat Washer	4
E	0003-047-000	Hex Head Cap Screw	10
F	0016-028-000	Nylon Hex Nut	10
G	1020-031-038	Fowler Rest Bumper	2
H	1037-031-017	Fowler Rest, Right	1
J	1037-031-019	Fowler Rest, Left	1

[Return To Table of Contents](#)

Pneumatic Fowler Assembly

1037-031-010 Rev A (Reference Only)

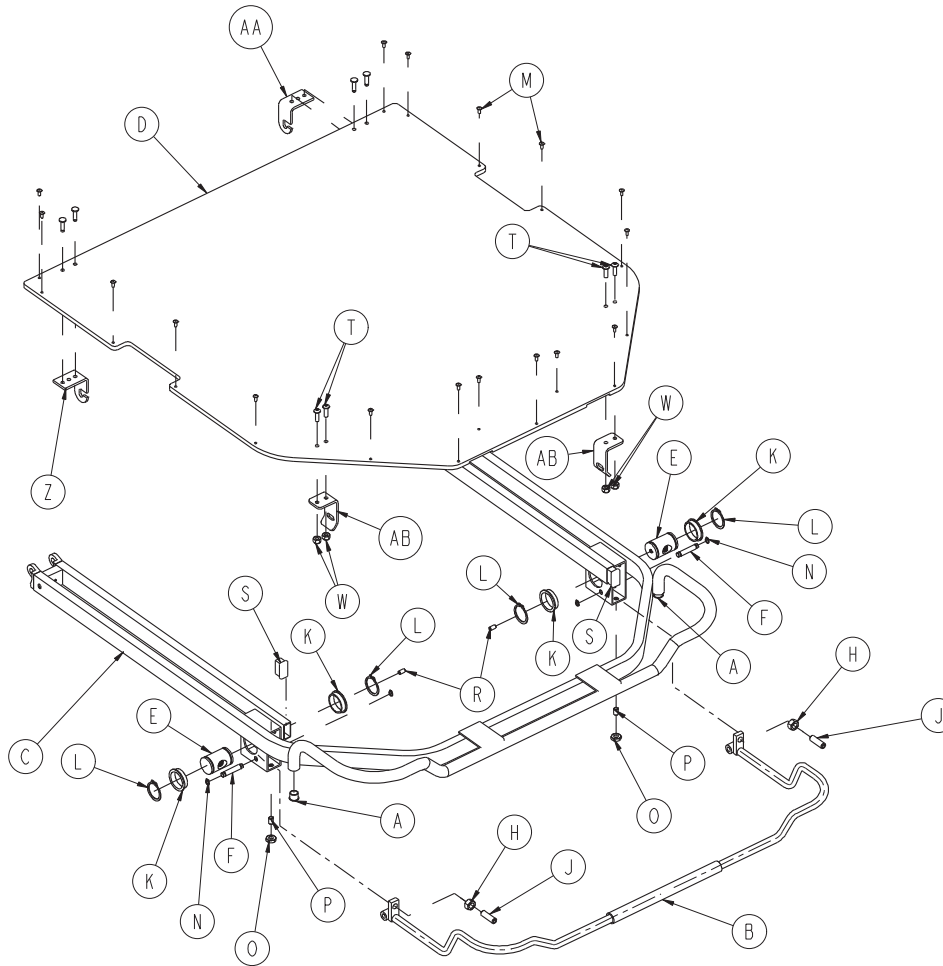

Item	Part No.	Part Name	Qty.
A	0037-065-000	Heyco Hole Plug	2
B	1020-031-020	Handle Assembly	1
C	1037-031-015	Fowler Weldment	1
D	1020-031-039	Fowler Skin	1
E	1510-031-028	Yoke	2
F	1510-031-037	Pivot	2
H	0015-050-000	Hex Hut	2
J	0021-126-000	Set Screw	2
K	0946-035-025	Liner	4
L	0028-076-000	External Retaining Ring	4
M	0025-099-000	Pop Rivet	17
N	0028-008-000	External Retaining Ring	4
O	0015-037-000	Hex Jam Nut	2
P	0021-104-000	Set Screw	2
R	0021-119-000	Set Screw	2
S	1010-032-066	Rectangle Hole Plug	2
T	0004-149-000	Button Head Cap Screw	4
W	0016-003-000	Nylock Hex Nut	4
Y	0025-069-000	Pop Rivet	4
Z	1020-023-012	Tray Handle, Left Hand	1
AA	1020-023-013	Tray Latch	1
AB	1020-023-014	Tray Latch	2

[Return To Table of Contents](#)

Transfer Board Assembly

1037-024-020 Rev A (Reference Only)

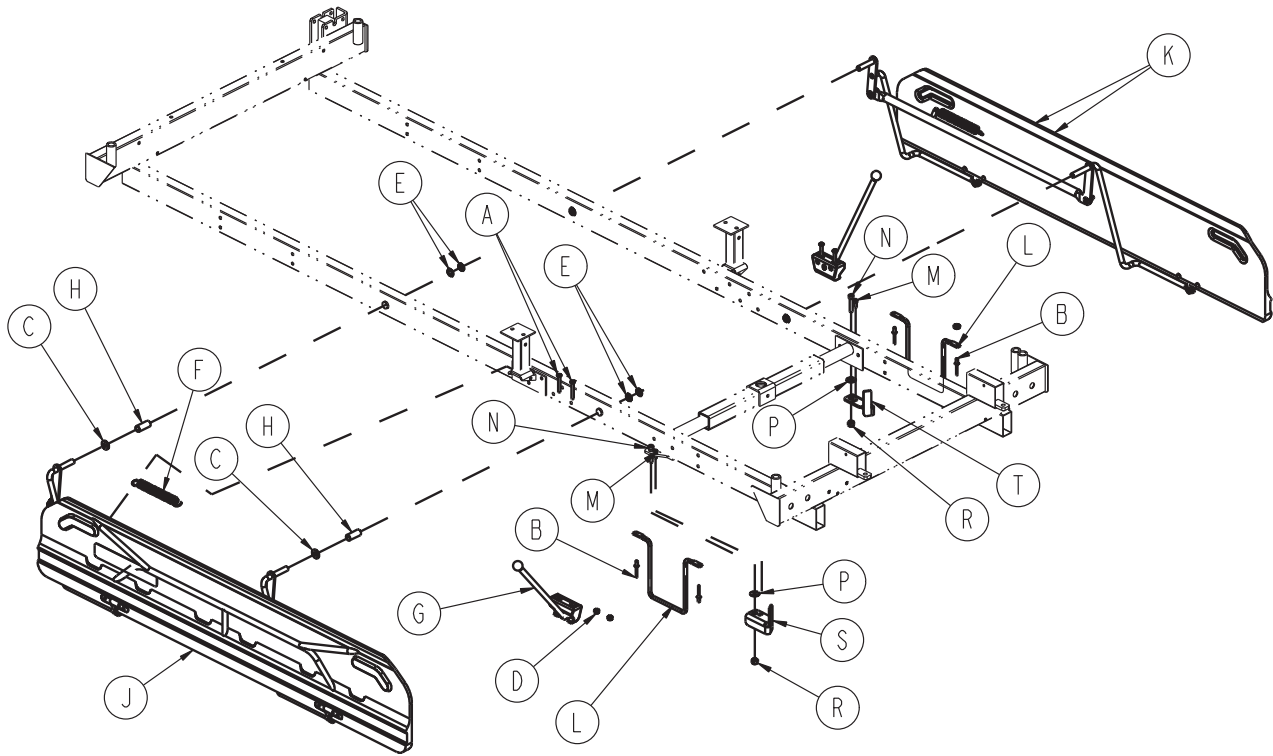

Item	Part No.	Part Name	Qty.
A	0002-100-000	Pan Head Machine Screw	4
B	0025-079-000	Pop Rivet	4
C	0014-021-000	Washer	4
D	0016-003-000	Fiberlock Hex Nut	4
E	0028-093-000	Retaining Ring	8
F	0038-252-000	Extension Spring	2
G	1010-024-030	Board Support Assembly (page 94)	2
H	1020-001-029	Bearing	4
J	1037-024-010	Transfer Board System, Left (page 92)	1
K	1037-024-011	Transfer Board System, Right (page 93)	1
L	1020-024-121	Board Retainer	2
M	0004-032-000	Socket Head Cap Screw	2
N	0004-142-000	Socket Head Cap Screw	2
P	0011-179-000	Nylon Washer	2
R	0016-028-000	Nylock Nut	2
S	1020-024-034	Support Plate, Left	1
T	1020-024-035	Support Plate, right	1

[Return To Table of Contents](#)

Transfer Board Assembly, Left - 1037-024-010

Rev A

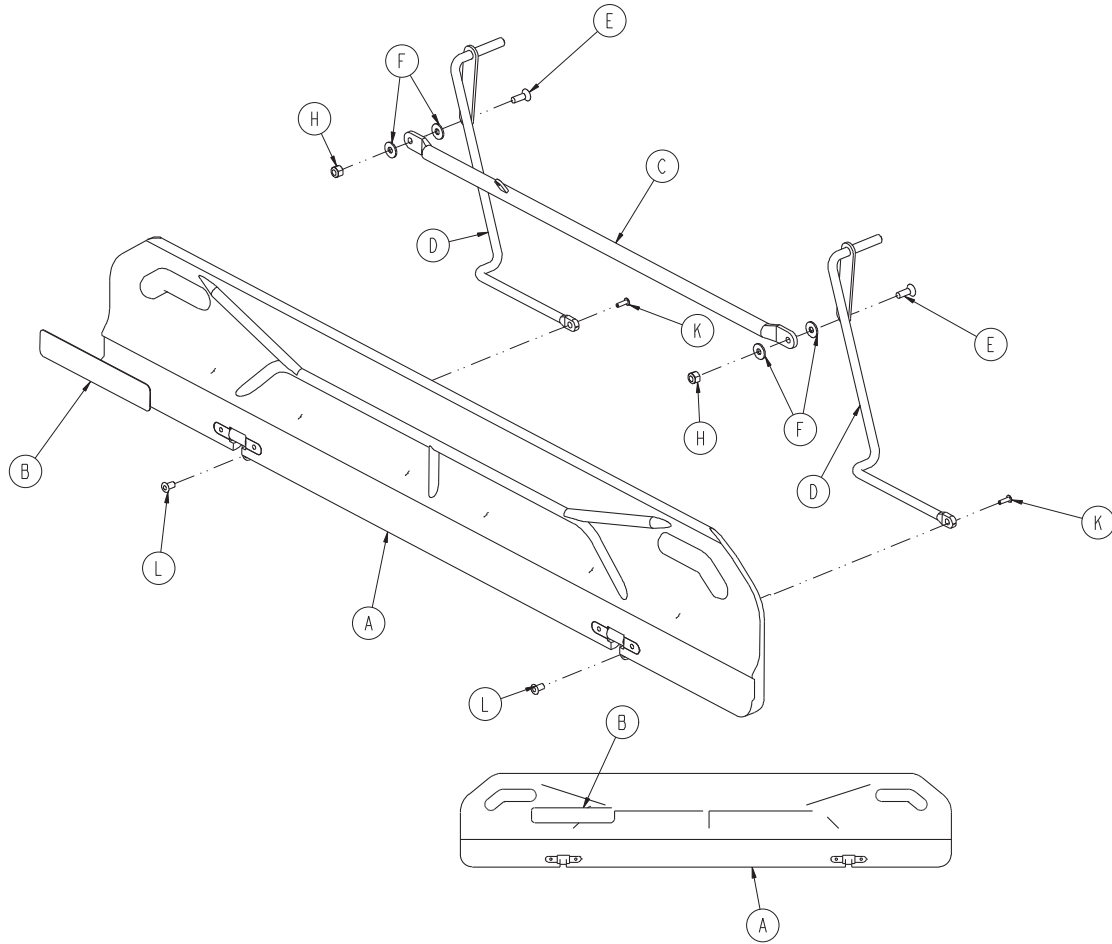

Item	Part No.	Part Name	Qty.
A	1037-032-100	Transfer Board Assembly	1
B	0721-024-046	Label	1
C	1037-024-038	Connecting Link Assembly	1
D	1020-024-012	Pivot Arm Assembly, Left	2
E	0001-025-000	Flat Head Machine Screw	2
F	0011-224-000	Nylon Flat Washer	4
H	0016-028-000	Nylock Hex Nut	2
K	0025-157-000	Rivet	2
L	1211-132-025	Pivot Sleeve	2

Transfer Board Assembly, Right - 1037-024-011

Rev A

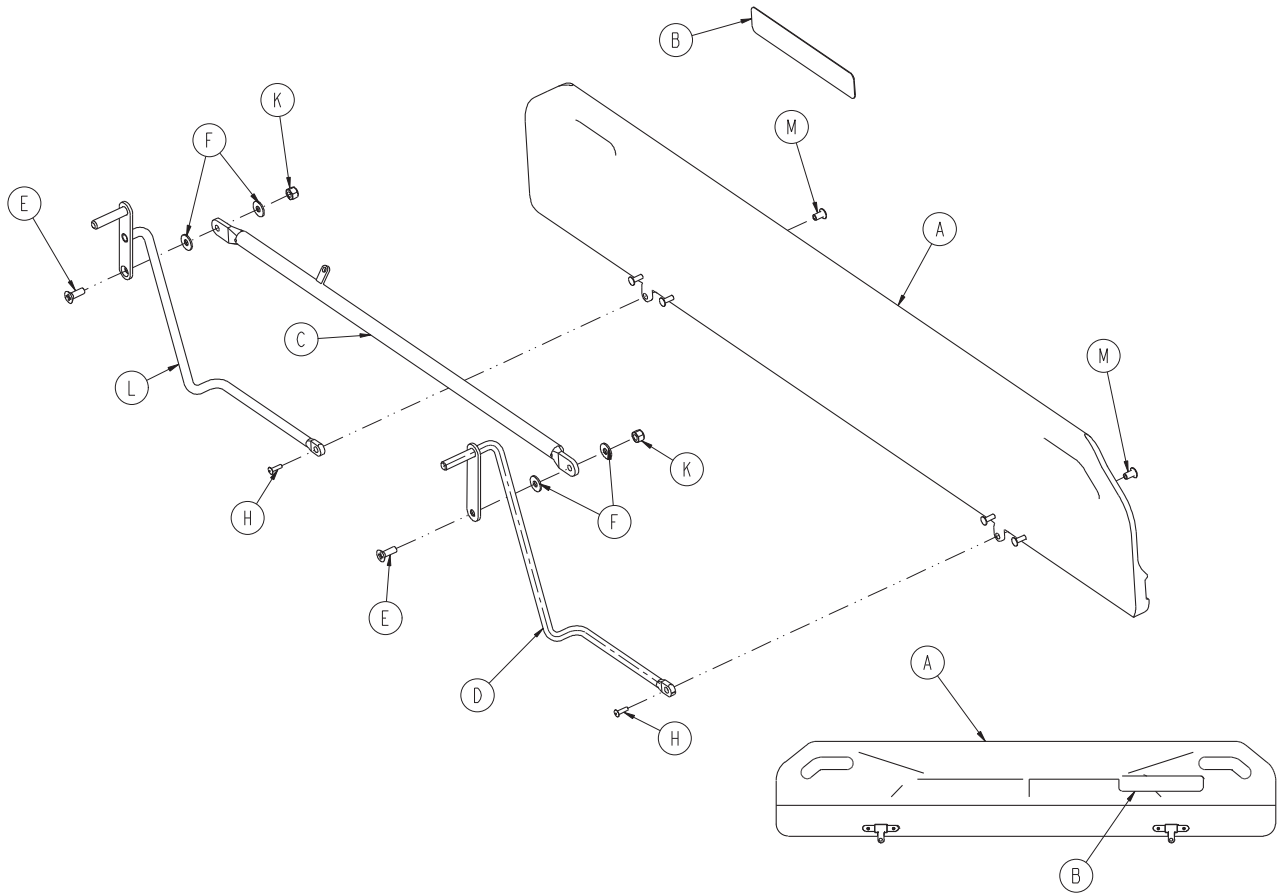

Item	Part No.	Part Name	Qty.
A	1037-032-100	Transfer Board Assembly	1
B	0721-024-046	Label	1
C	1037-024-037	Connecting Link Assembly	1
D	1020-024-013	Pivot Arm Assembly	1
E	0001-025-000	Flat Head Machine Screw	2
F	0011-224-000	Nylon Flat Washer	4
H	0025-157-000	Rivet	2
K	0016-028-000	Nylock Hex Nut	2
L	1020-024-033	Pivot Arm Assembly, Right	1
M	1211-132-025	Pivot Sleeve	2

[Return To Table of Contents](#)

Arm Board Support Assembly - 1010-024-030

Rev C

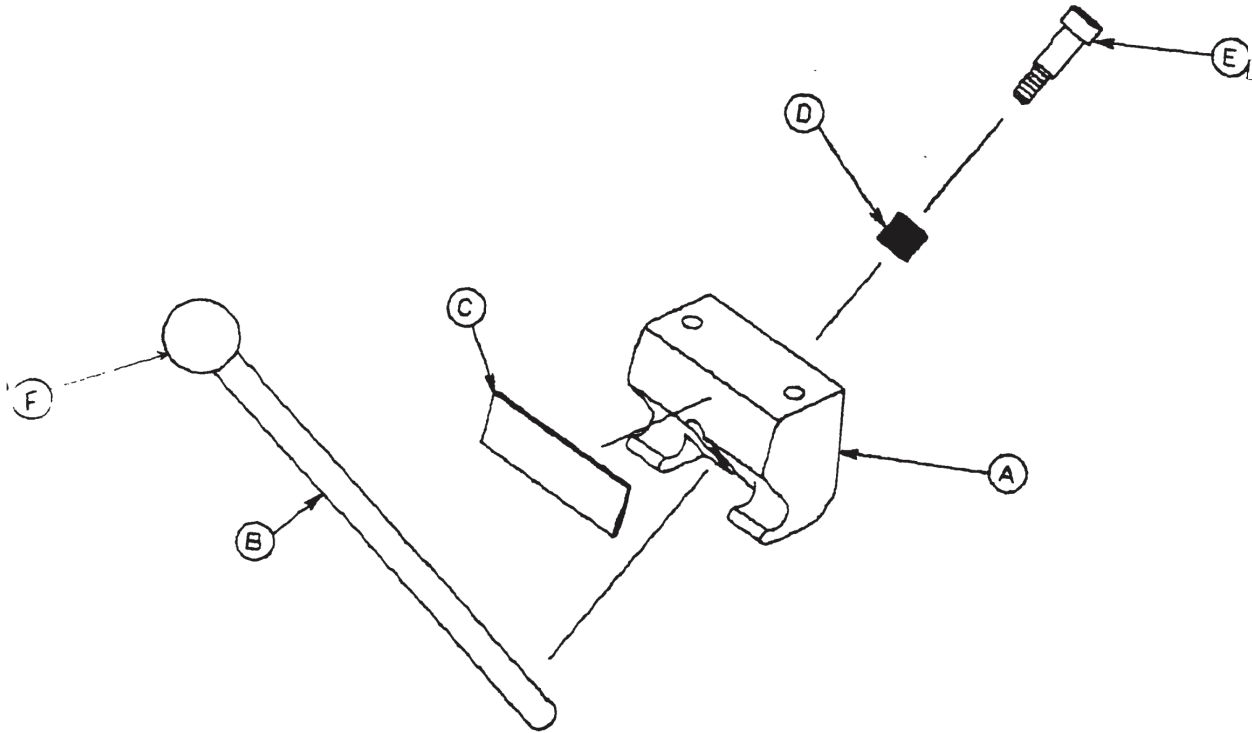

Item	Part No.	Part Name	Qty.
A	1010-024-015	Support Block	1
B	1010-024-016	Support Arm	1
C	1010-024-014	Label, Warning	1
D	0038-263-000	Compression Spring	1
E	0008-017-000	Shoulder Bolt	1
F	1010-026-046	Ball Knob	1

X-Ray Tray Assembly, Right Side Load - 1037-022-000

1037-022-010 Rev A (Reference Only)

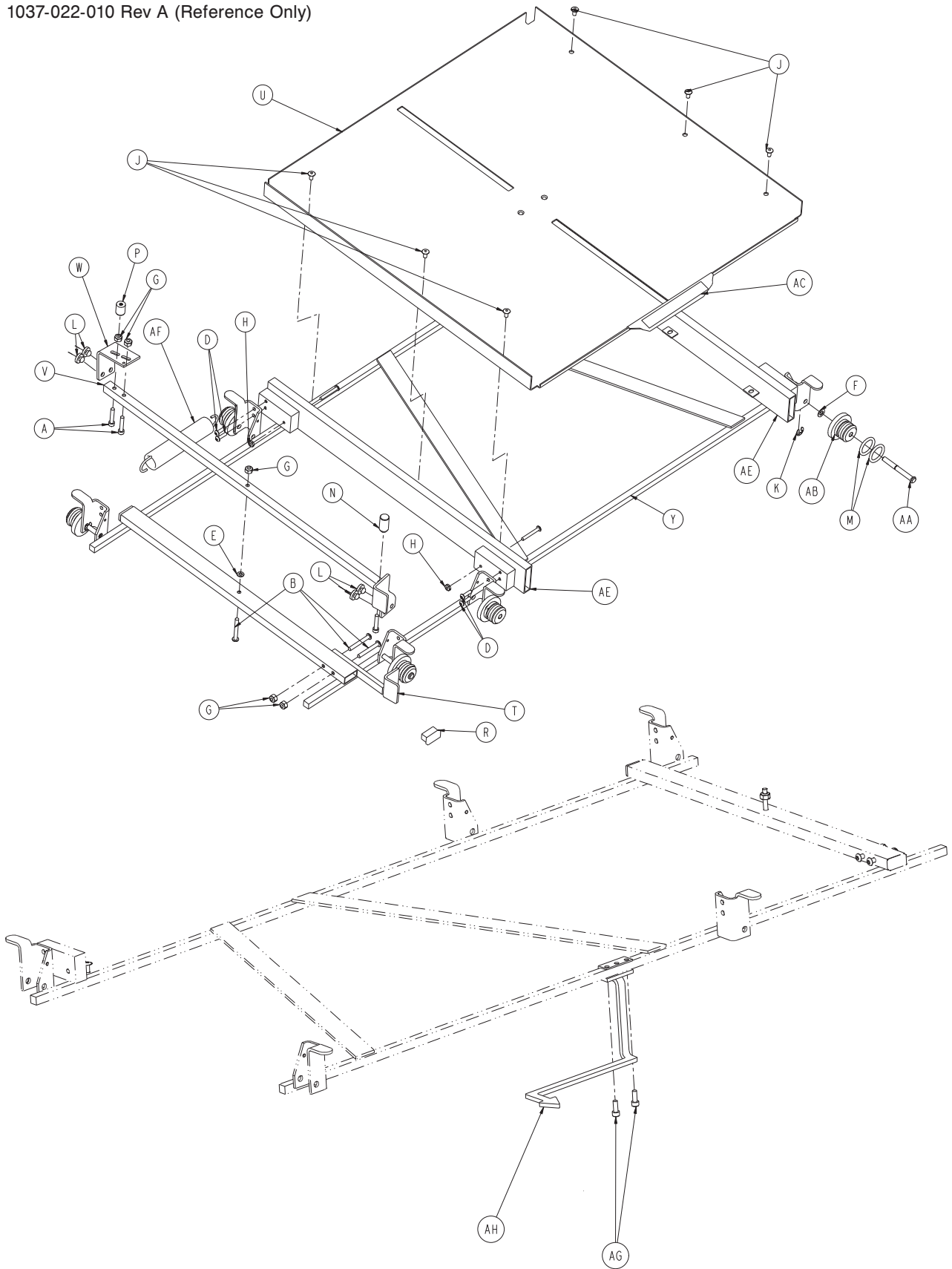

[Return To Table of Contents](#)

X-Ray Tray Assembly, Right Side Load - 1037-022-000

Item	Part No.	Part Name	Qty.
A	0004-026-000	Socket Head Cap Screw	3
B	0004-171-000	Button Head Cap Screw	3
C	0004-175-000	Button Head Cap Screw	4
D	0004-265-000	Button Head Cap Screw	8
E	0011-146-000	Washer	1
F	0014-004-000	Washer	6
G	0016-003-000	Nylock Hex Nut	5
H	0016-014-000	Nylock Hex Nut	4
J	0025-079-000	Rivet	6
K	0028-098-000	E-Ring	6
L	0037-064-000	Bumper, Grommet	4
M	0045-952-000	O-Ring	12
N	1010-022-035	Retention Spacer, Right	1
P	1010-022-036	Retention Spacer, Left	1
R	1010-032-066	Hole Plug	2
T	1020-022-007	Brake Handle	1
U	1037-021-014	Tray Pan	1
V	1020-022-015	Pivot Tube Assembly	1
W	1020-022-036	Brake Adjustment Bracket	1
Y	1037-022-044	Frame Assembly	1
AA	1020-022-025	Wheel Axle	6
AB	1020-022-059	Wheel	6
AC	1020-022-060	Label, Yellow	1
AD	1020-022-061	X-Ray Tray Spacer	4
AE	1020-022-062	Drawer Slides	1
AF	0038-253-000	Extension Spring	1
AG	0004-032-000	Socket Head Cap Screw	2
AH	1020-021-012	Tray Indicator Weldment, Right	1

X-Ray Tray Assembly, Left Side Load - 1037-021-000

1037-021-010 Rev A (Reference Only)

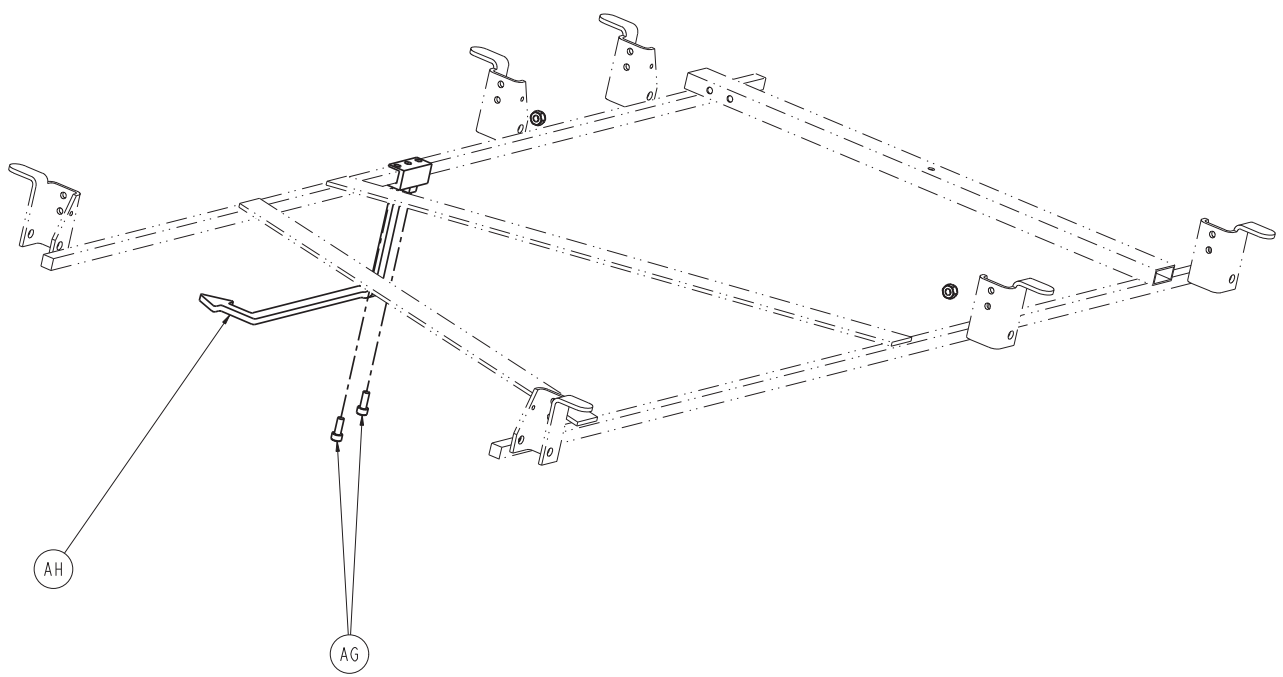
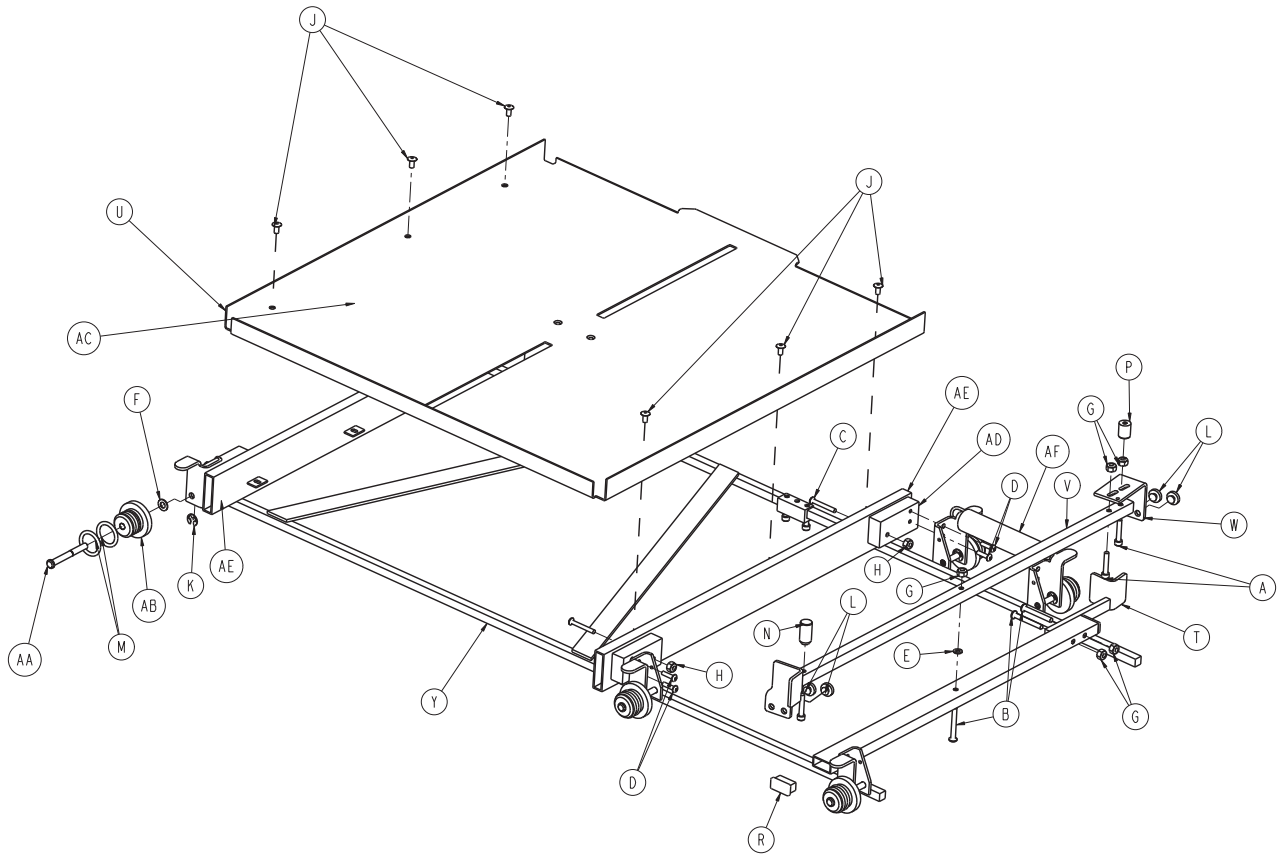

[Return To Table of Contents](#)

X-Ray Tray Assembly, Left Side Load - 1037-021-000

Item	Part No.	Part Name	Qty.
A	0004-026-000	Socket Head Cap Screw	3
B	0004-171-000	Button Head Cap Screw	3
C	0004-175-000	Button Head Cap Screw	4
D	0004-265-000	Button Head Cap Screw	8
E	0011-146-000	Washer	1
F	0014-004-000	Washer	6
G	0016-003-000	Nylock Hex Nut	5
H	0016-014-000	Nylock Hex Nut	4
J	0025-079-000	Rivet	6
K	0028-098-000	E-Ring	6
L	0037-064-000	Bumper, Grommet	4
M	0045-952-000	O-Ring	12
N	1010-022-035	Retention Spacer, Right	1
P	1010-022-036	Retention Spacer, Left	1
R	1010-032-066	Hole Plug	2
T	1020-021-007	Brake Handle	1
U	1037-021-014	Tray Pan	1
V	1020-021-015	Pivot Tube Assembly	1
W	1020-021-036	Brake Adjustment Bracket	1
Y	1037-021-044	Frame Assembly	1
AA	1020-022-025	Wheel Axle	6
AB	1020-022-059	Wheel	6
AC	1020-022-060	Label, Yellow	1
AD	1020-022-061	X-Ray Tray Spacer	4
AE	1020-022-062	Drawer Slides	1
AF	0038-253-000	Extension Spring	1
AG	0004-032-000	Socket Head Cap Screw	2
AH	1020-021-017	Tray Indicator Weldment, Right	1

X-Ray Grid Holder Assembly - 1020-027-000

1020-027-010 Rev A (Reference Only)

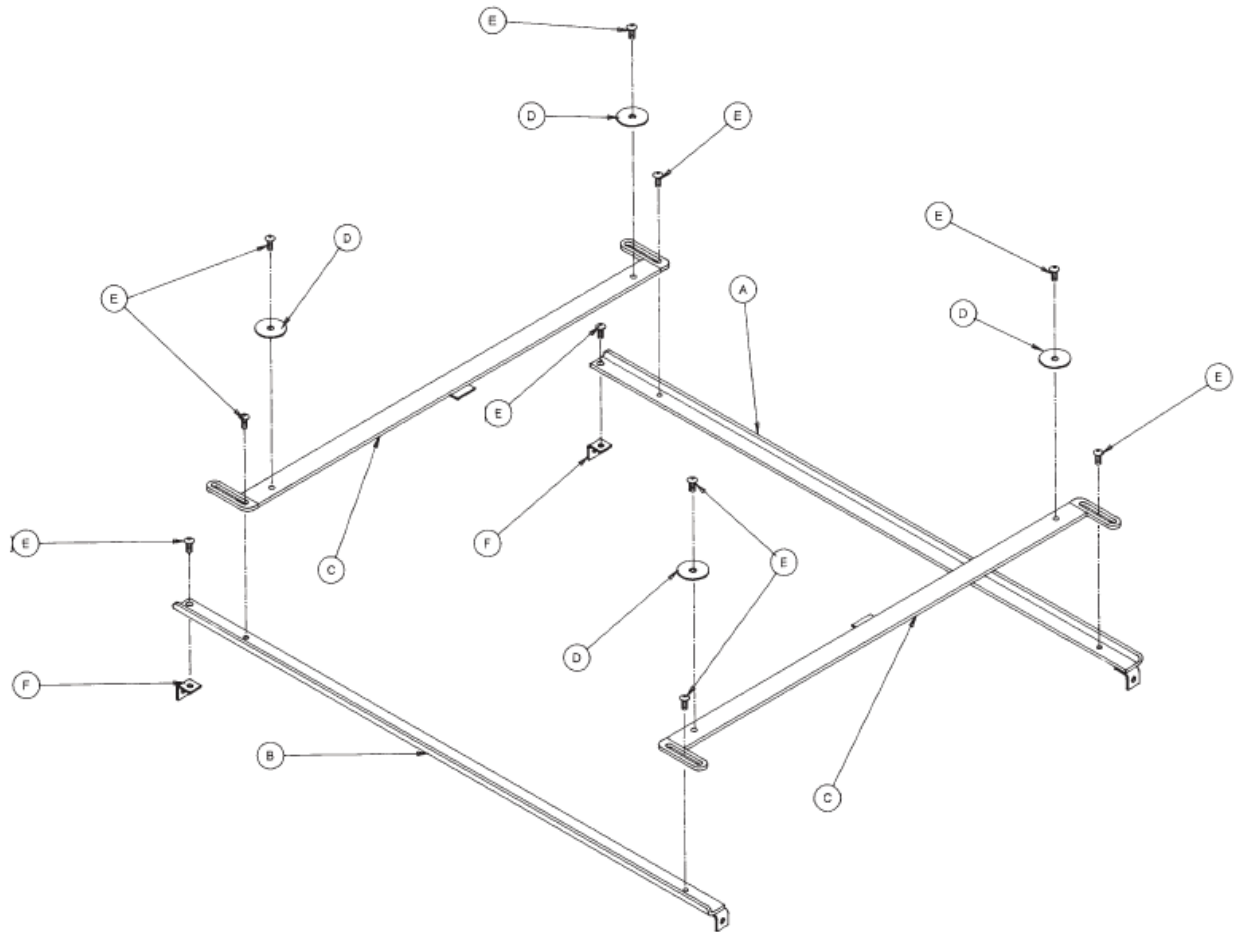

Item	Part No.	Part Name	Qty.
A	1020-027-021	Guide Weldment, Right	1
B	1020-027-022	Guide Weldment, Left	1
C	1020-027-011	Slider Weldment	2
D	0011-271-000	Fender Washer	4
E	0004-131-000	Button Head Cap Screw	10
F	1020-027-024	L Bracket	2

[Return To Table of Contents](#)

Optional X-Ray Centering Guide - 1020-020-000

Rev C

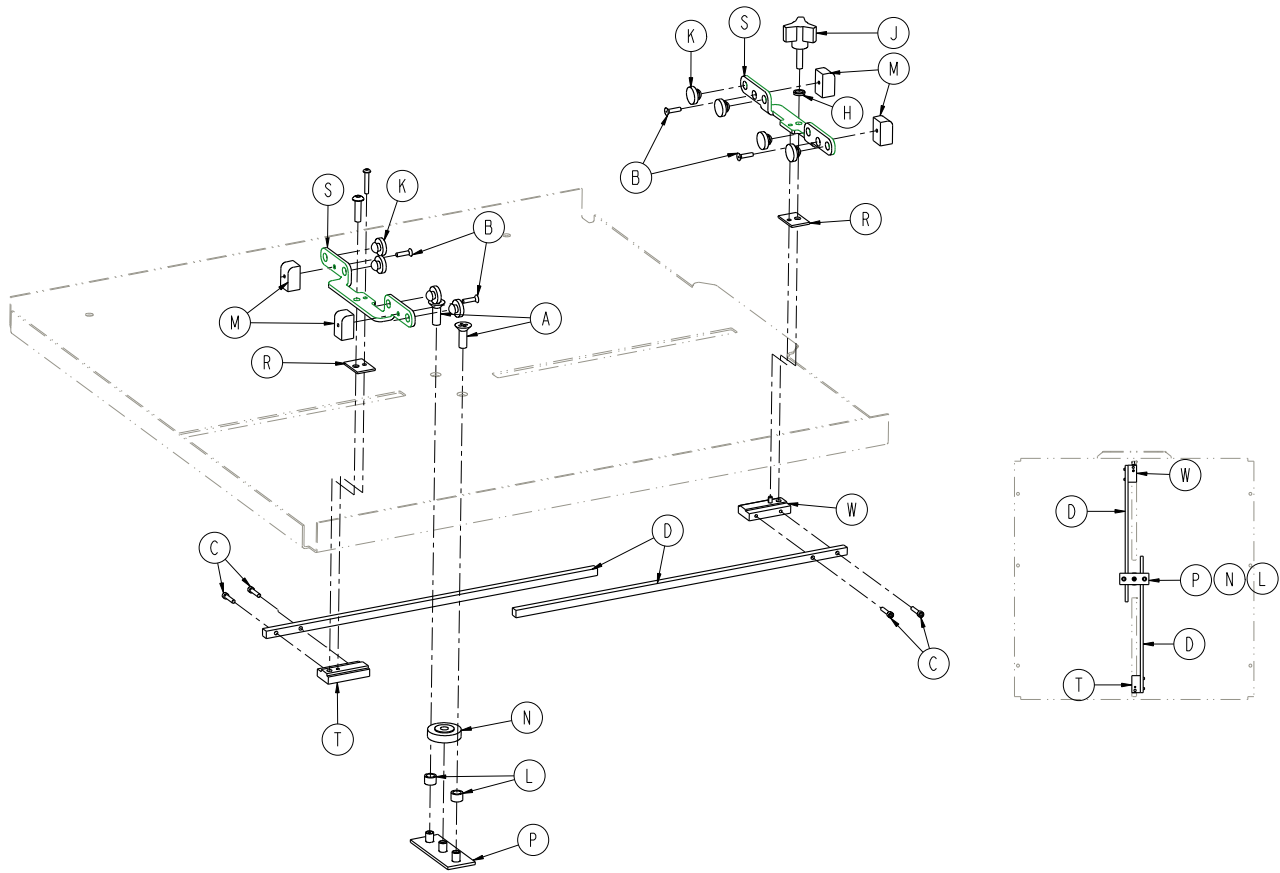

Item	Part No.	Part Name	Qty.
A	0001-026-000	Flat Head Countersunk Machine Screw	2
B	0001-085-000	Countersunk Flat Head	4
C	0004-127-000	Socket Head Cap Screw	4
D	0004-169-000	Button Head Cap Screw	1
E	0004-170-000	Button Head Cap Screw	1
H	0011-132-000	Flat Washer	1
J	0024-051-000	Medium Utility Clamping Knobs	1
K	0037-064-000	Grommet Bumpers	8
L	0052-250-000	Special Nylon Spacers	2
M	1020-022-021	Slide Block	4
N	1020-022-041	Spur Gear Modified	1
O	1020-022-043	Rack Gear Modified	2
P	1020-022-052	Guide Plate Assembly	1
R	1020-022-055	Slide Pad	2
S	1020-022-056	Centering Plate	2
T	1020-022-057	Rack Connector, Left	1
W	1020-022-058	Rack Connector Assembly	1

Optional Push Handles, Head End - 1037-151-000

Rev A

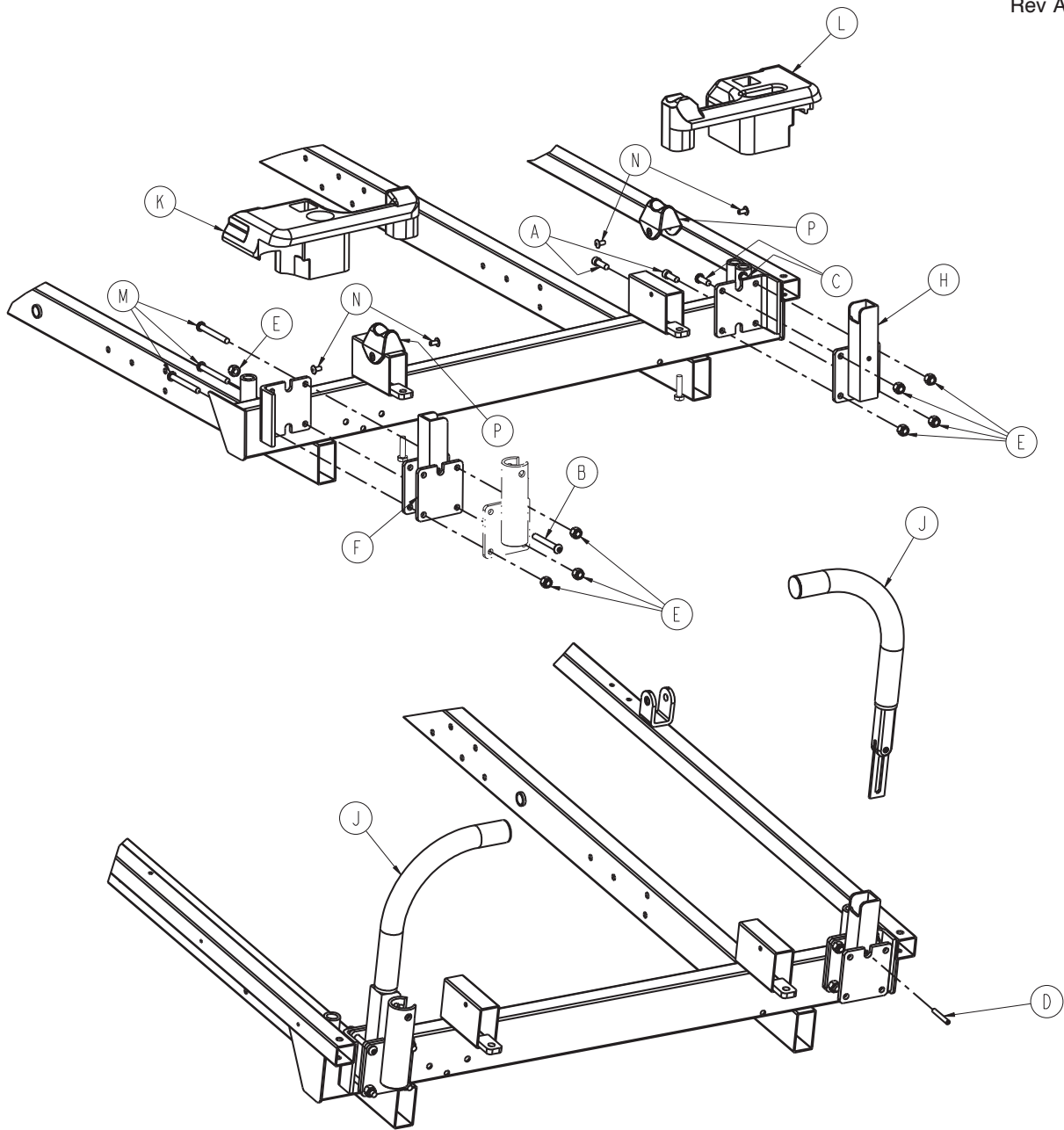

Item	Part No.	Part Name	Qty.
A	0004-009-000	Socket Head Cap Screw	2
B	0004-097-000	Hex Socket Button Head Cap Screw	1
C	0004-161-000	Socket Button Head Cap Screw	2
D	0026-012-000	Roll Pin	2
E	0016-028-000	Hex Nut	8
F	1037-054-070	Socket Assembly, Left	1
H	1037-054-071	Socket Assembly, Right	1
J	1211-351-010	Push Handle Assembly (page 102)	2
K	1010-001-015	Head End Cover, Left	1
L	1010-001-016	Head End Cover, Right	1
M	0004-163-000	Hex Socket Button Head Cap Screw	3
N	0025-079-000	Dome Head Pop Rivet	4
P	1010-001-035	Handle Rest	2

[Return To Table of Contents](#)

Push Handle Assembly - 1211-351-010

Rev A

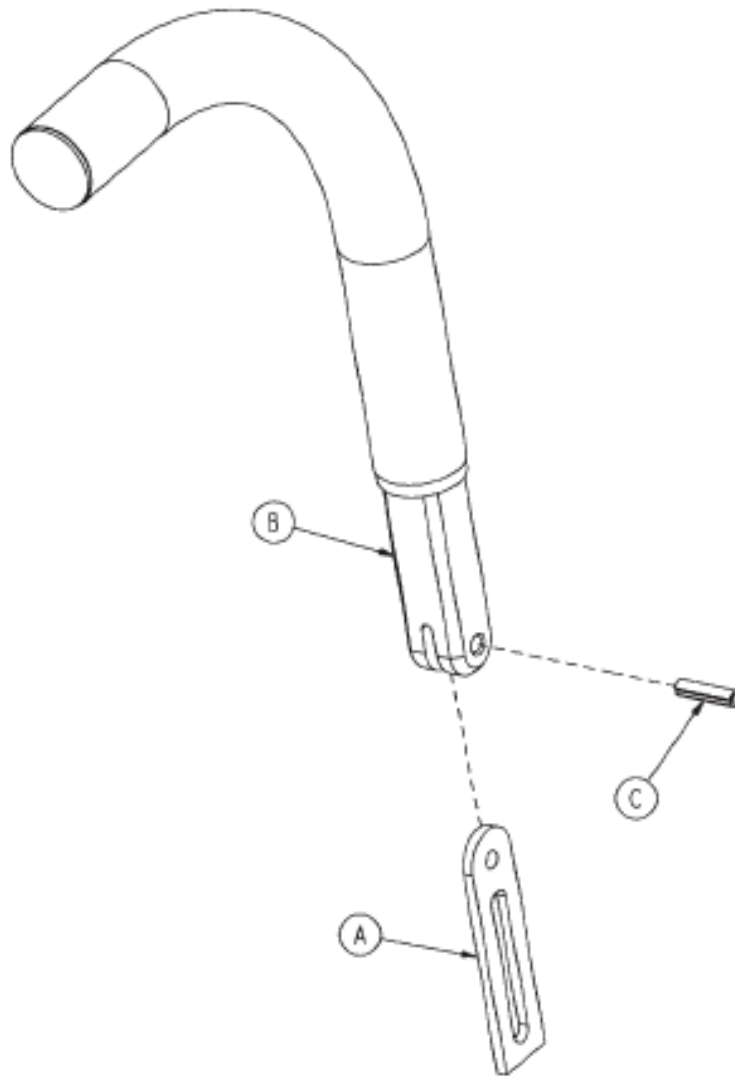

Item	Part No.	Part Name	Qty.
A	1010-354-024	Stop Link	1
B	1211-151-018	Sleeve Assembly	1
C	0026-118-000	Spring Pin	1

Optional Push Handles, Foot End - 1037-051-000

1037-051-010 Rev A (Reference Only)

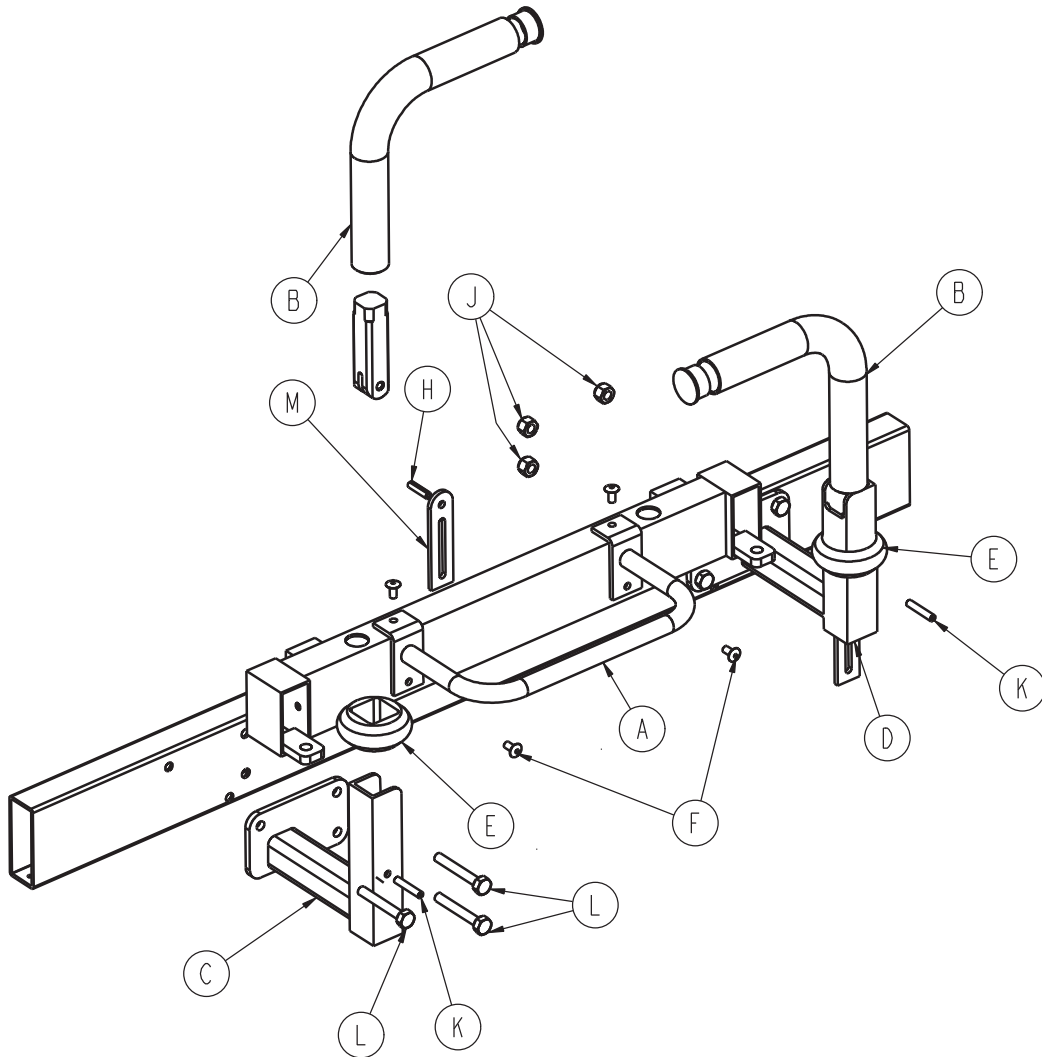

Item	Part No.	Part Name	Qty.
A	1010-051-019	Guard	1
B	1000-058-019	Push Handle	2
C	1037-051-015	Handle Socket	1
D	1037-051-017	Handle Socket	1
E	1010-051-018	Rubber Bumper	2
F	0025-079-000	Pop Rivet	4
H	0026-010-000	Roll Pin	2
J	0016-028-000	Nylock Nut	6
K	0026-011-000	Roll Pin	2
L	0003-078-000	Hex Head Bolt	6
M	1010-354-024	Stop Link	2

[Return To Table of Contents](#)

Push Handle Assembly With I.V., Head End - 1037-151-004

Rev A

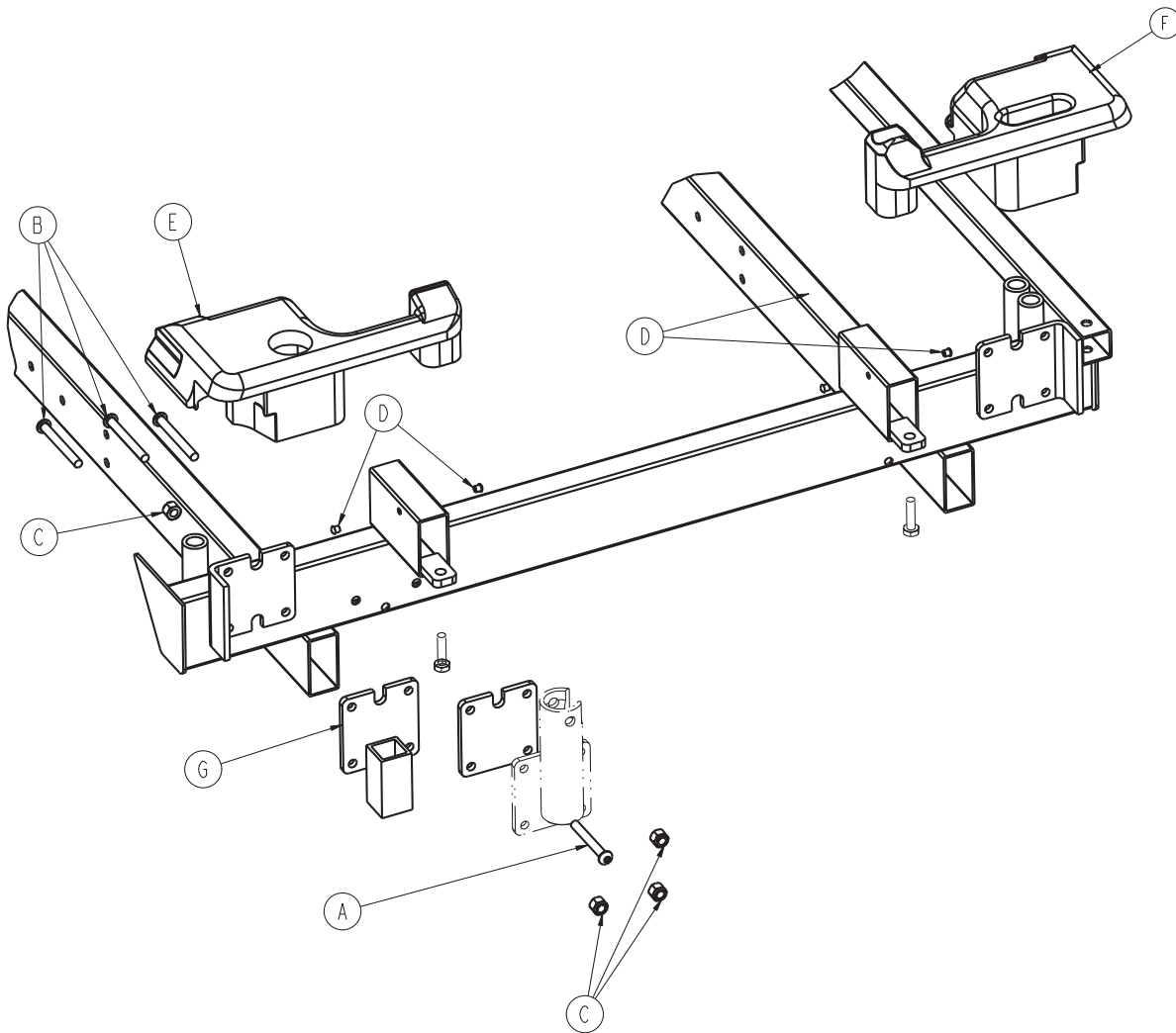

Item	Part No.	Part Name	Qty.
A	0004-097-000	Hex Socket Button Head Cap Screw	1
B	0004-163-000	Hex Socket Button Head Cap Screw	3
C	0016-028-000	Fiberlock Hex Nut	4
D	0037-074-000	Hole Plug	4
E	1010-001-013	Foot End Cover, Right	3
F	1010-001-014	Foot End Cover, Left	3
G	1037-054-067	I.V. Spacer Weldment	2

Push Handle Assembly Without I.V., Head End - 1020-151-001

Rev D

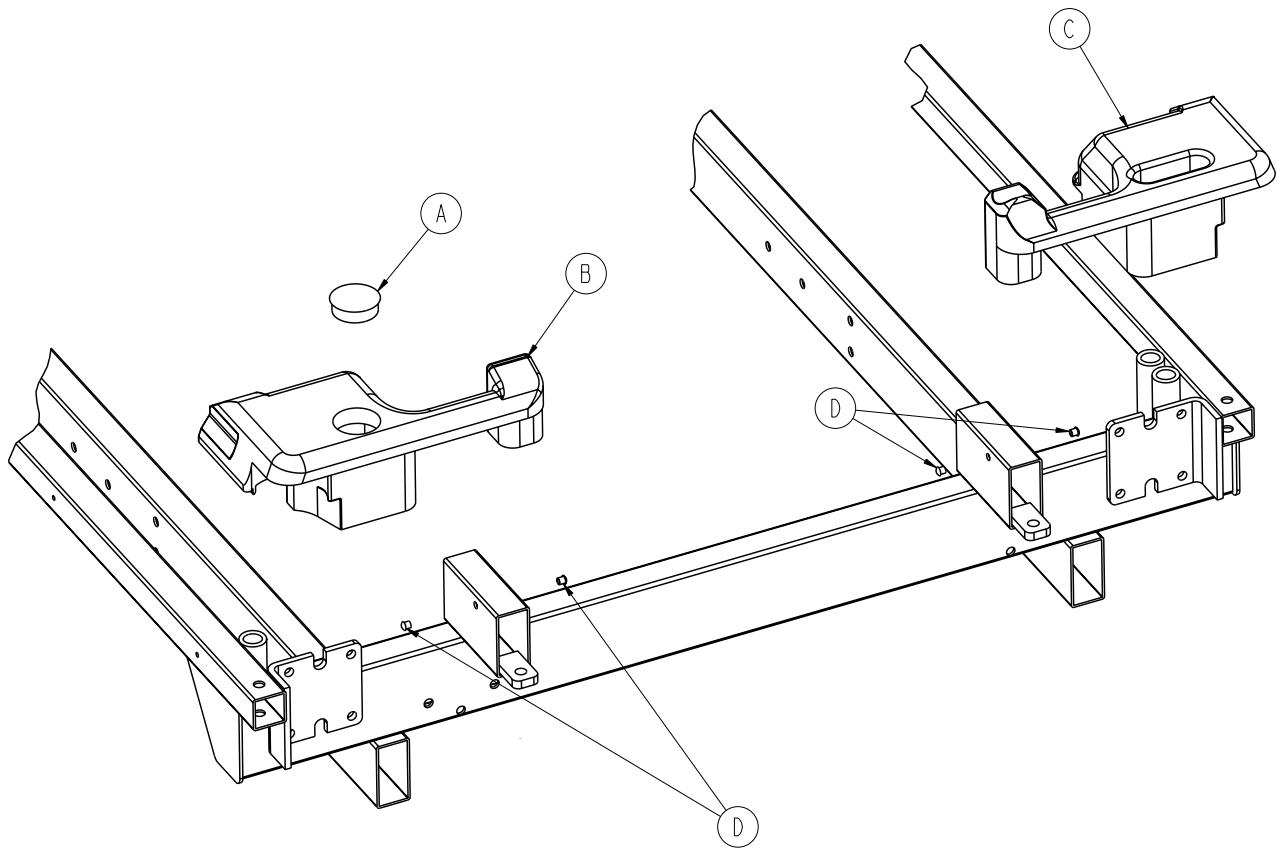

Item	Part No.	Part Name	Qty.
A	0037-059-000	Hole Plug	1
B	1010-001-013	Foot End Cover, Right	1
C	1010-001-014	Foot End Cover, Left	1
D	0037-074-000	Hole Plug	4

[Return To Table of Contents](#)

Cover Assembly with Pop Up Push Handles, Head End

- 1037-151-005

Rev A

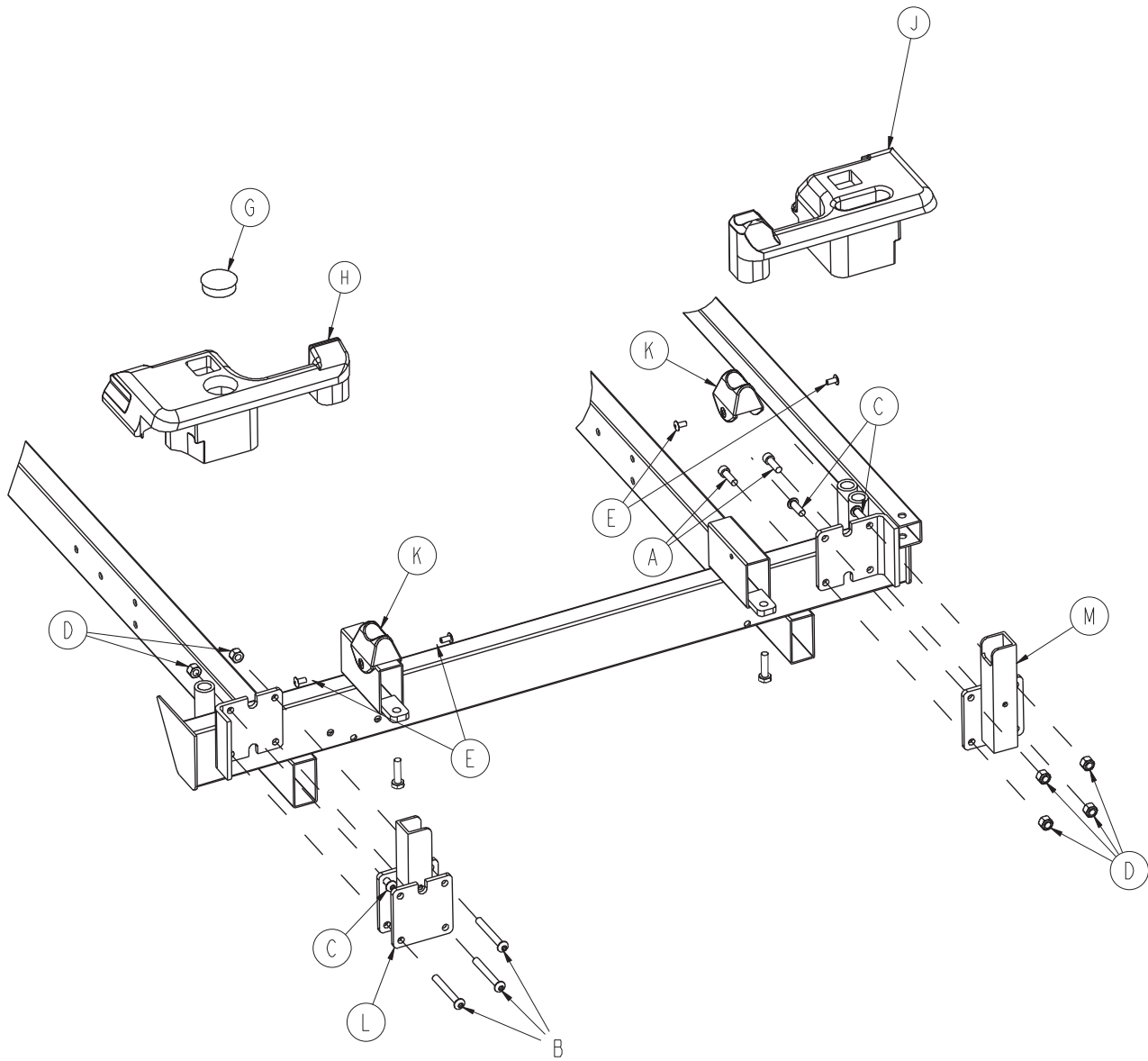

Cover Assembly with Pop Up Push Handles, Head End

- 1037-151-005

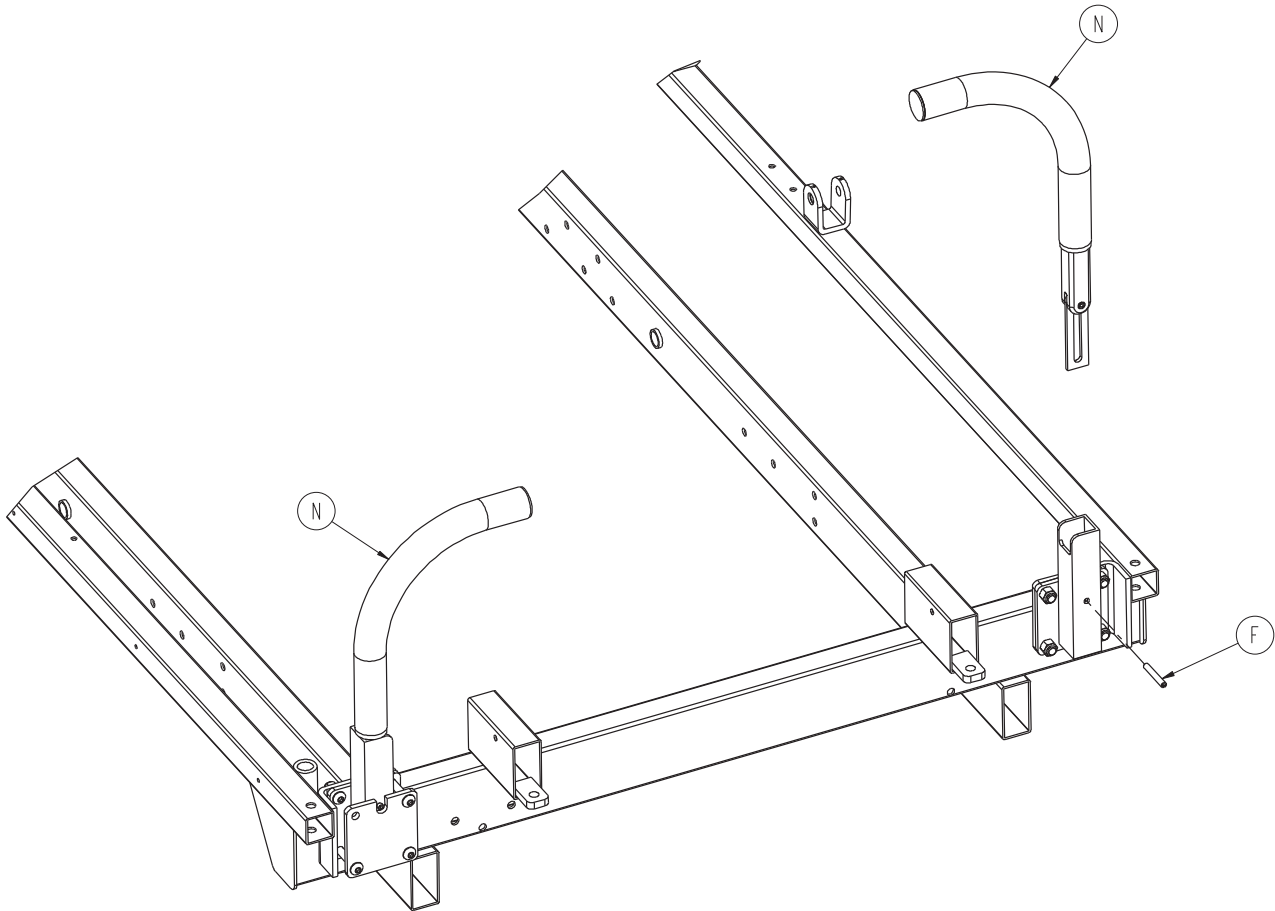

Item	Part No.	Part Name	Qty.
A	0004-009-000	Socket Head Cap Screw	2
B	0004-097-000	Hex Socket Button Head Cap Screw	3
C	0004-161-000	Button Head Cap Screw	3
D	0016-028-000	Fiberlock Hex Nut	8
E	0025-079-000	Dome Head Pop Rivet	4
F	0026-012-000	Roll Pin	2
G	0037-059-000	Hole Plug	1
H	1010-001-015	Head End Cover, Left	1
J	1010-001-016	Head End Cover, Right	1
K	1010-001-035	Handle Rest	2
L	1037-054-070	Socket Assembly, Left	1
M	1037-054-071	Socket Assembly, Right	1
N	1211-351-010	Push Handle Assembly (page 102)	2

[Return To Table of Contents](#)

Optional Accessories

Accessory	Part Number	Page
C-Spine Cassette Holder	1020-070-000	109
C-Spine Storage Bracket Assembly	1020-070-019	110
C-Spine Support Pole Assembly	1010-070-010	111
Defibrillator Tray	1105-045-200	112
Defibrillator Tray/Foot Extender	1105-045-400	113
Footboard/Chartholder	1105-045-500	114
Fowler X-Ray Cassette	1020-023-000	115
Heel Stirrups	1020-055-010	116
I.V. Caddy	0785-155-000	117
I.V. Pole, Removable	0390-025-000	118
I.V. Pole, Tethered	1001-087-018	119
I.V. Pole, Two-Stage Permanent, Head End	1010-081-000	120
I.V. Pole, Three-Stage Permanent, Head End	1020-061-000	121
I.V. Pole, Three-Stage Permanent, Foot End	1020-062-000	121
I.V. Pole, Two-Stage Permanent, Foot End	1010-080-000	122
Oxygen Bottle Holder, Upright	1115-130-000	123
Serving/Instrument Tray	1105-045-700	124
Serving Tray Holder/Footboard	1105-045-800	125
Mattress and Siderail Pads		126

C-Spine Cassette Holder Assembly - 1020-070-000

Rev -

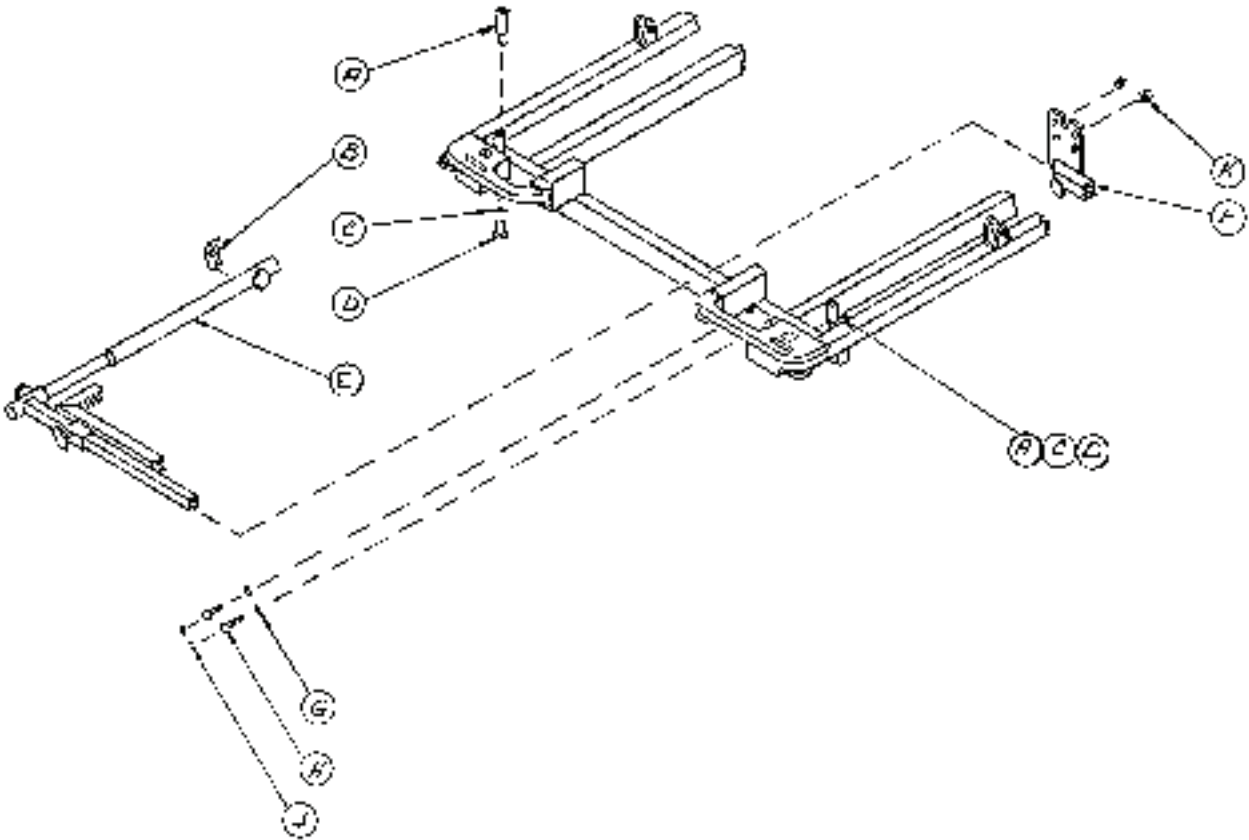

Item	Part No.	Part Name	Qty.
A	1010-070-025	I.V. Adaptor	2
B	1020-070-018	Label, Specification	1
C	0011-003-000	Washer	2
D	0004-054-000	Socket Head Screw	2
E	1010-070-010	Support Pole Assembly	1
F	1020-070-019	Storage Bracket Assembly	1
G	0037-056-000	Washer	2
H	0003-047-000	Hex Head Screw	2
J	0037-055-000	Cap	2
K	0016-005-000	Nut	2

[Return To Table of Contents](#)

C-Spine Storage Bracket Assembly - 1020-070-019

Rev A

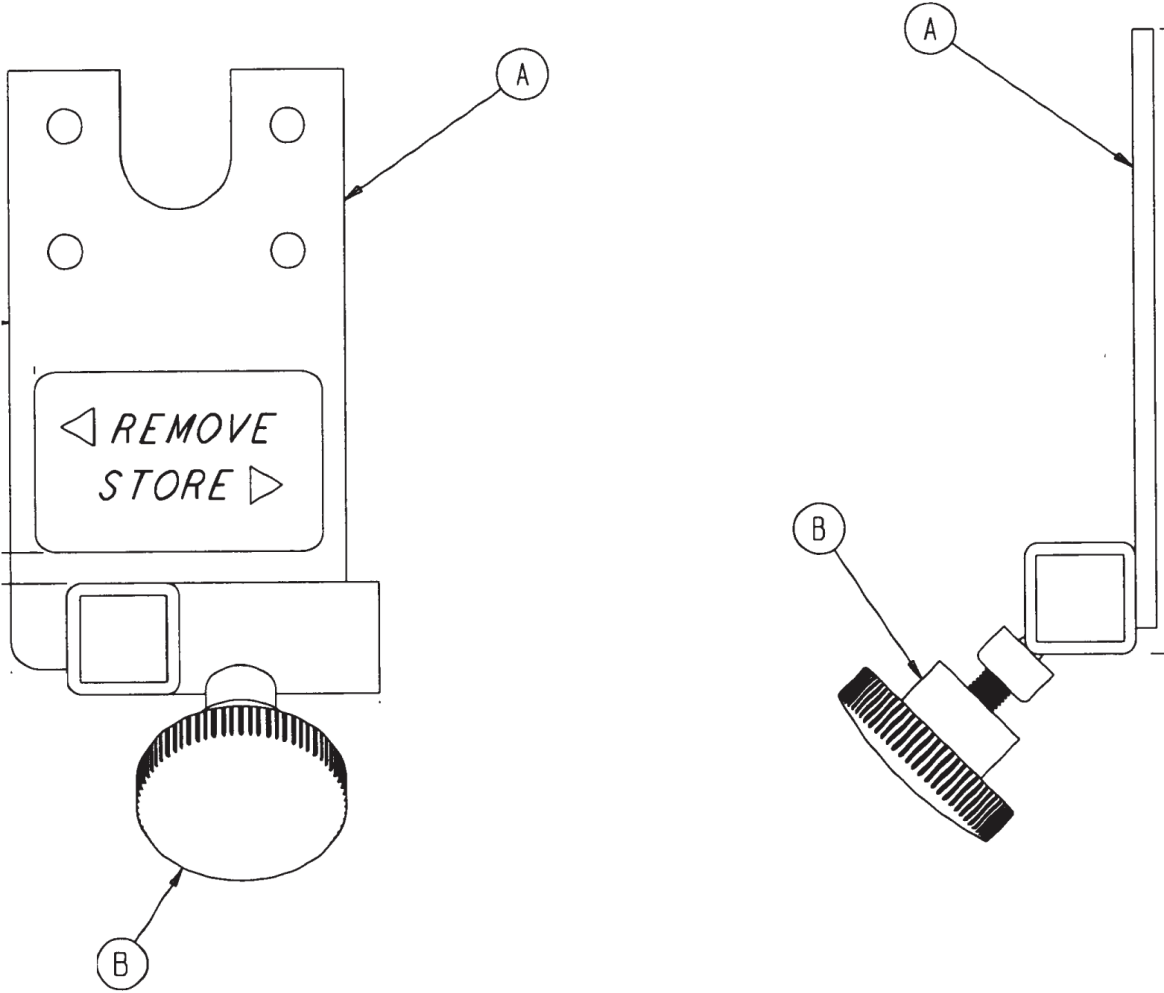

Item	Part No.	Part Name	Qty.
A	1020-070-020	Storage Bracket Weldment	1
B	1010-070-045	Knob	1
C	1010-070-023	Storage Decal	1

C-Spine Support Pole Assembly - 1010-070-010

Rev C

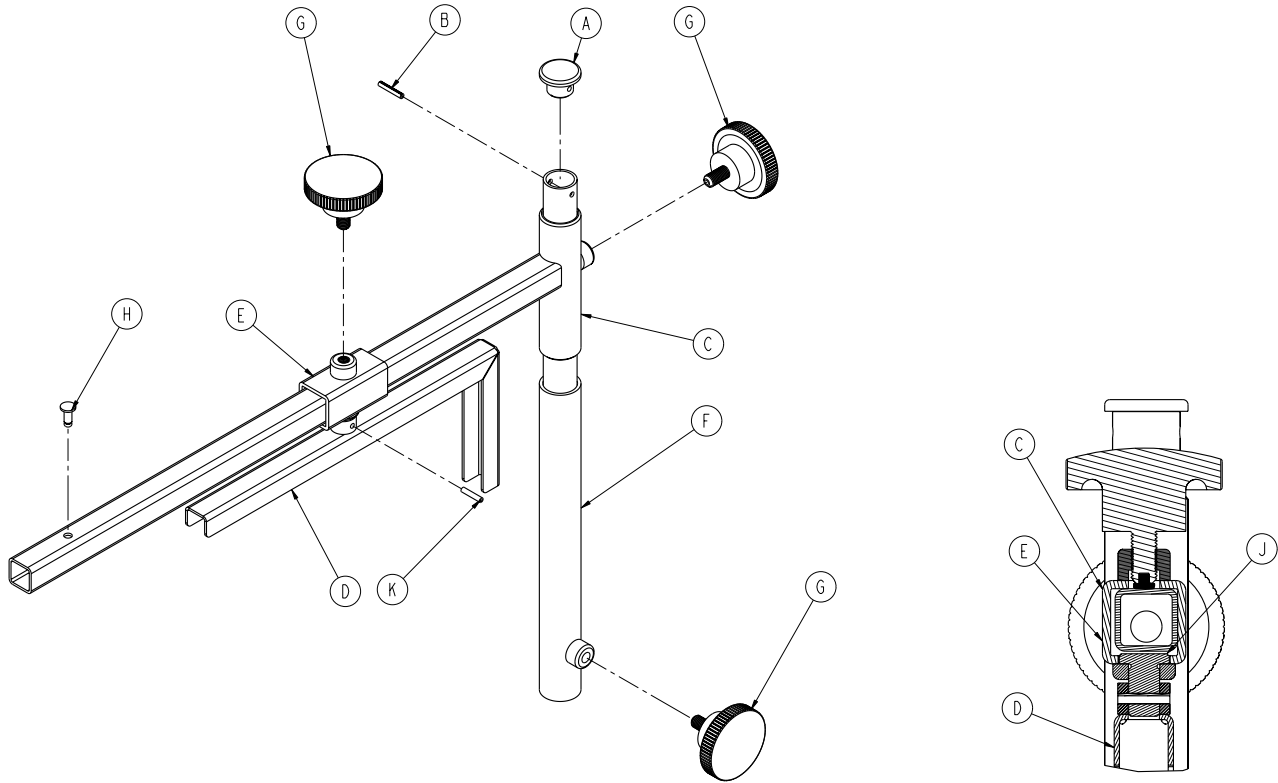

Item	Part No.	Part Name	Qty.
A	1010-070-033	Support Tube Cap	1
B	0026-646-000	Slotted Spring Pin	1
C	1010-070-034	Support Arm Weldment	1
D	1010-070-042	Cassette Holder Weldment	1
E	1010-070-050	Adjustment Tube Weldment	1
F	1010-070-030	Base Tube Weldment	1
G	1010-070-045	Plastic Knob	3
H	0025-055-000	Pop Rivet	1
J	1010-070-044	Pivot Pin	1
K	0026-005-000	Roll Pin	1

[Return To Table of Contents](#)

Defibrillator Tray Assembly - 1105-045-200

Rev A

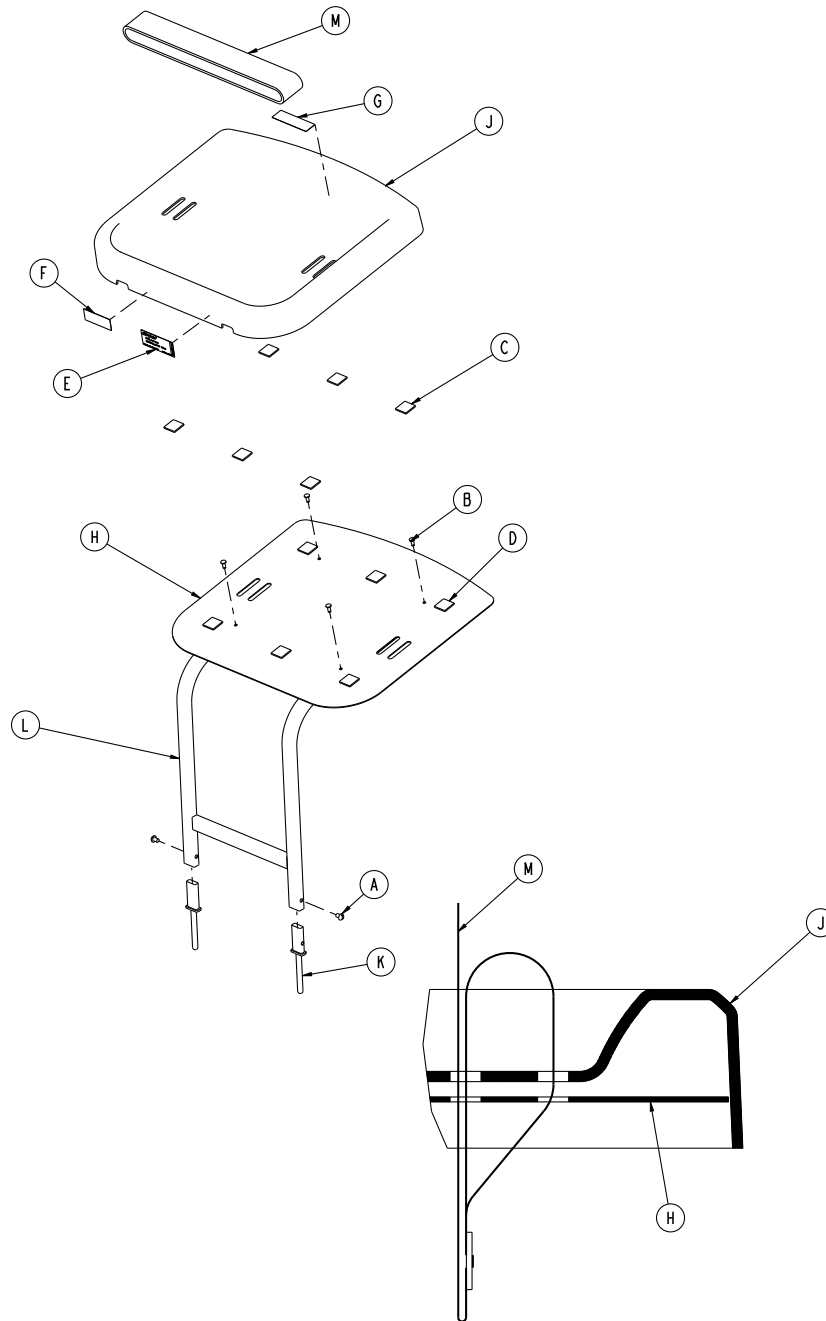

Item	Part No.	Part Name	Qty.
A	0002-044-000	Round Head Machine Screw	2
B	0025-055-000	Blind Hole Rivet	4
C	0029-008-000	Dual Lock	6
D	0029-010-000	Dual Lock	6
E	1105-045-201	Label, Defibrillator Tray	1
F	1105-045-402	Label, Push/Pull	1
G	1105-045-403	Label, Weight Capacity	1
H	1105-045-204	Tray Support	1
J	1105-045-207	Tray	1
K	0785-045-208	Bayonet	2
L	1105-045-210	Defibrillator Tray Frame Weldment	1
M	1010-050-021	Long Strap	1

[Return To Table of Contents](#)

Defibrillator Tray/Foot Extender/Foot Board - 1105-045-400

Rev A

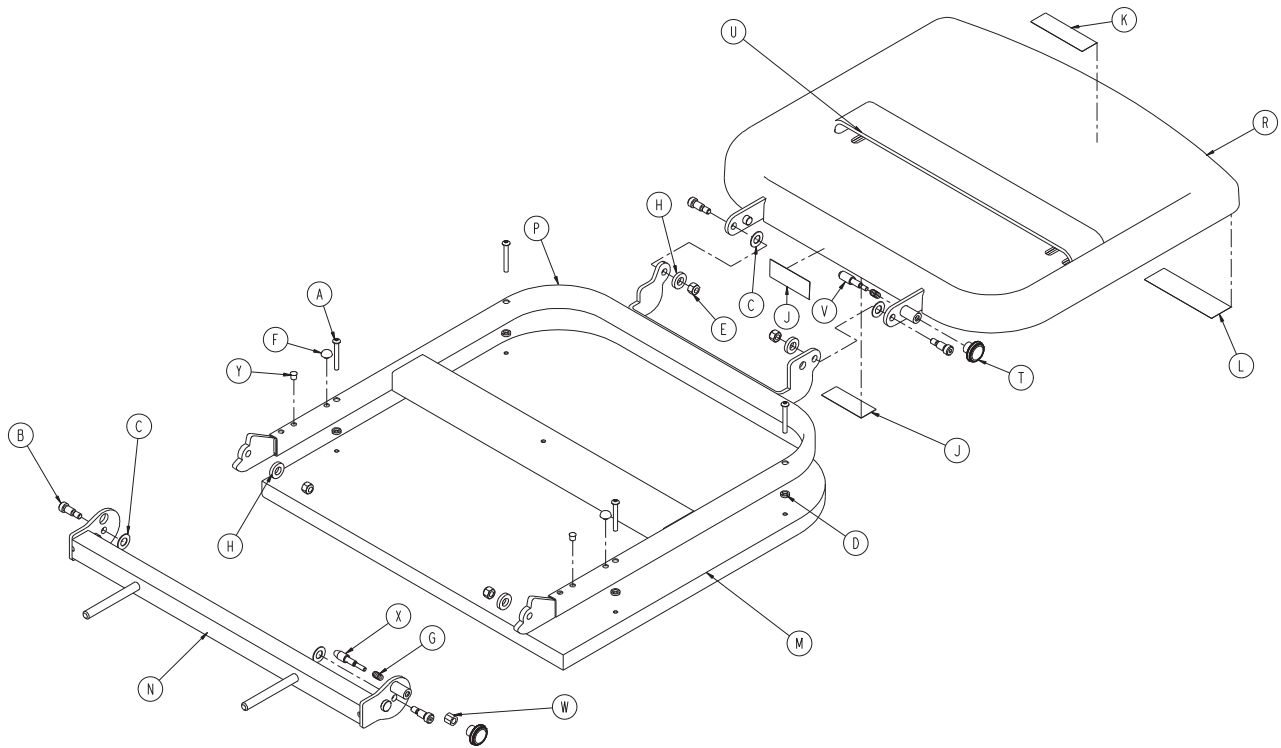

Item	Part No.	Part Name	Qty.
A	0004-215-000	Button Head Cap Screw	4
B	0008-049-000	Socket Head Cap Screw	4
C	0014-020-000	Washer	4
D	0014-120-000	Washer	4
E	0016-028-000	Hex Nut	4
F	0037-052-000	Rubber Bumper	2
G	0038-133-000	Compression Spring	2
H	0052-017-000	Spacer	4
J	1105-045-402	Label, Push/Pull	2
K	1105-045-403	Label, Weight Capacity	1
L	1105-045-401	Label, Foot Extender/Defib Tray	1
M	0785-045-405	Cushion	1
N	0785-045-410	Base Mounting Weldment	1
P	0785-045-420	Frame Pivot Weldment	1
R	0747-045-430	Tray Assembly	1
T	0785-045-450	Knob	2
U	1010-050-021	Long Strap	1
V	1010-050-242	Pin Lock	1
W	1010-050-250	Lock Adjuster	1
X	1010-050-248	Lower Pin Lock	1
Y	0721-031-065	Hole Plug	2

[Return To Table of Contents](#)

Footboard/Chartholder Assembly - 1105-045-500

Rev A

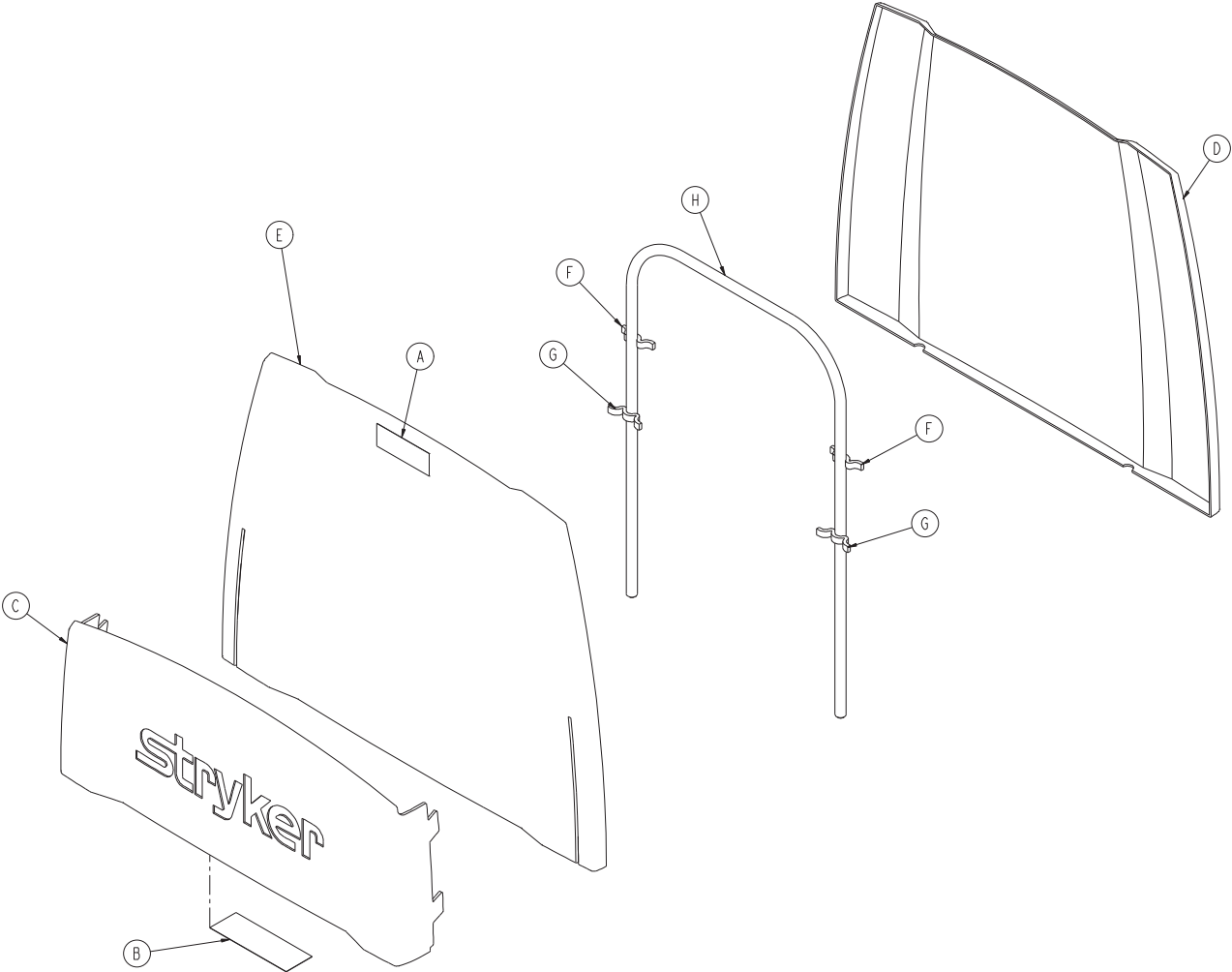

Item	Part No.	Part Name	Qty.
A	1105-045-402	Label, Push/Pull	1
B	1105-045-501	Label, Footboard	1
C	1105-045-511	Chartholder	1
D	1105-045-512	Footboard, Back	1
E	1105-045-513	Footboard, Front	1
F	1105-045-514	Small Standoff	2
G	1105-045-515	Large Standoff	2
H	0946-029-010	Support	1

Fowler X-Ray Cassette Assembly - 1020-023-000

Rev C

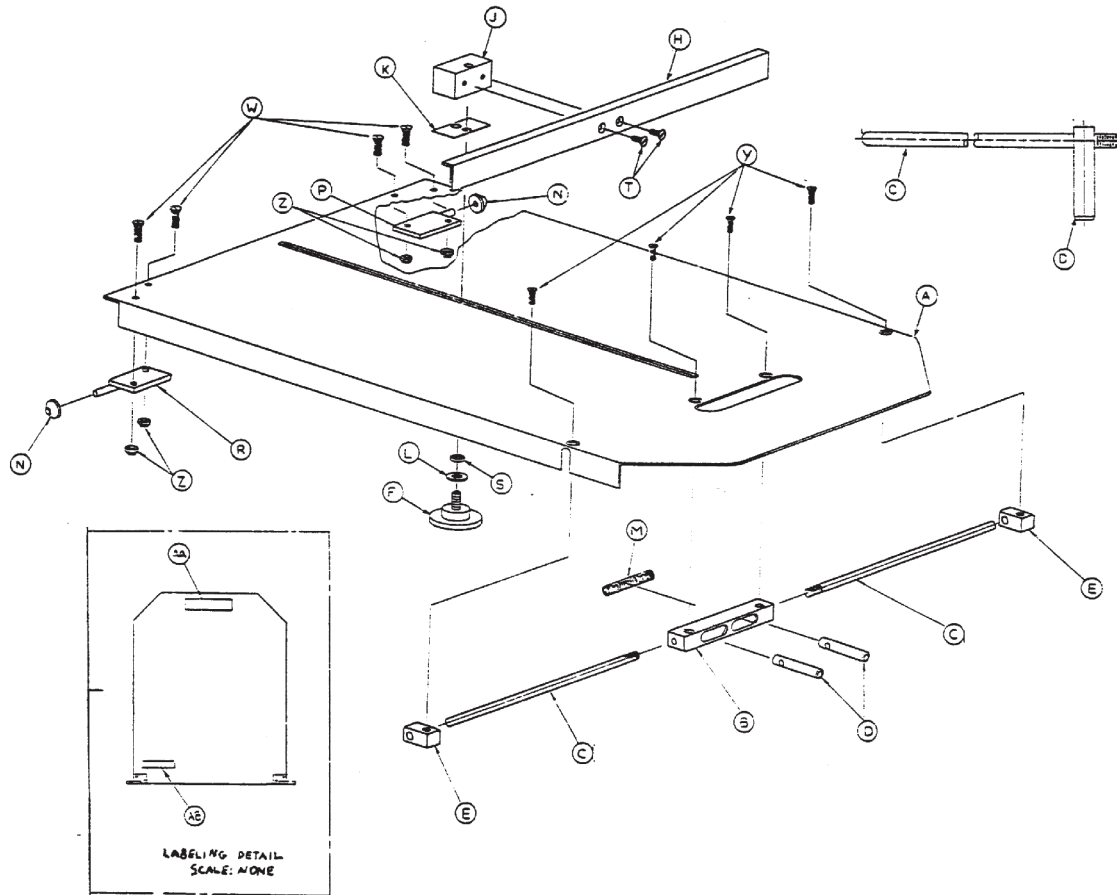

Item	Part No.	Part Name	Qty.
A	1020-023-011	Tray	1
B	1020-023-016	Post Housing	1
C	1020-023-025	Actuating Rod	2
D	0926-023-064	Post	2
E	1010-023-037	Rod Guide	2
F	1020-023-021	Knob	1
H	1010-023-028	Tray Angle	1
J	0926-023-070	Block Assembly	1
K	0926-023-069	Washer	1
L	0014-003-000	Washer	1
M	0038-122-000	Compression Spring	1
N	1020-023-026	Spacer	2
P	1020-023-019	Tray Hinge, Right Hand	1
R	1020-023-020	Tray Hinge, Left Hand	1
S	0926-023-071	Bushing	1
T	0001-020-000	Flat Head Machine Screw	2
W	0004-149-000	Hex Socket Button Cap Screw	4
Y	0001-022-000	Flat Head Screw	4
Z	0016-003-000	Nylock Nut	4
AA	1010-023-019	Label, Tray Removal	1
AB	1020-023-027	Label, Specification	1

[Return To Table of Contents](#)

Heel Stirrups - 1020-055-000

Rev A

1020-055-010 Rev - (Reference Only)

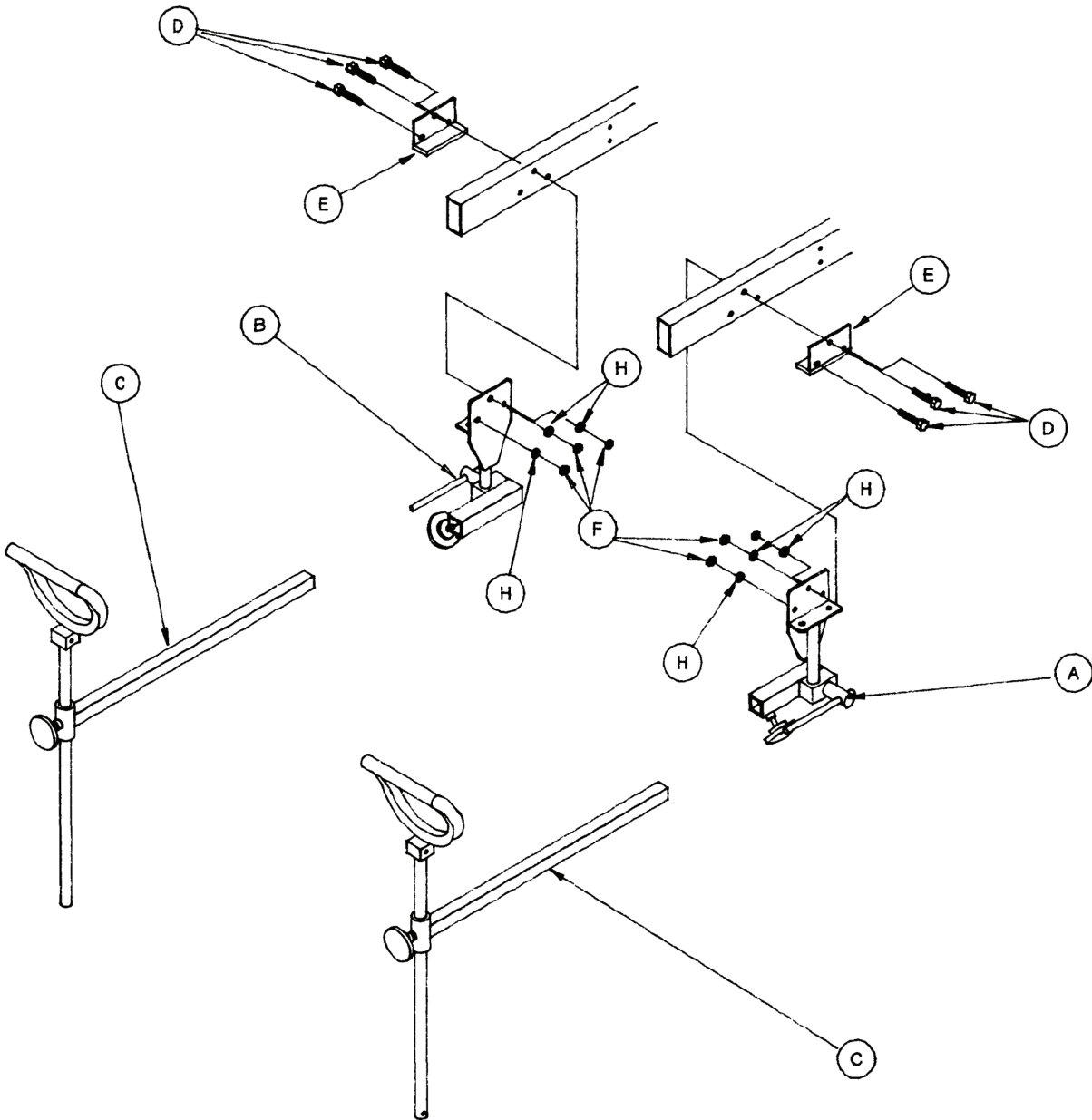

Item	Part No.	Part Name	Qty.
A	1010-055-015	Right Stirrup Support Assembly	1
B	1010-055-025	Left Stirrup Support Assembly	1
C	1010-055-029	Stirrup Assembly	2
D	0003-078-000	Hex Head Cap Screw	6
E	1020-055-015	Backer Assembly	2
F	0016-028-000	Nylock Hex Nut	6
H	0011-158-000	Flat Washer	6

I.V. Caddy - 0785-155-000

Rev A

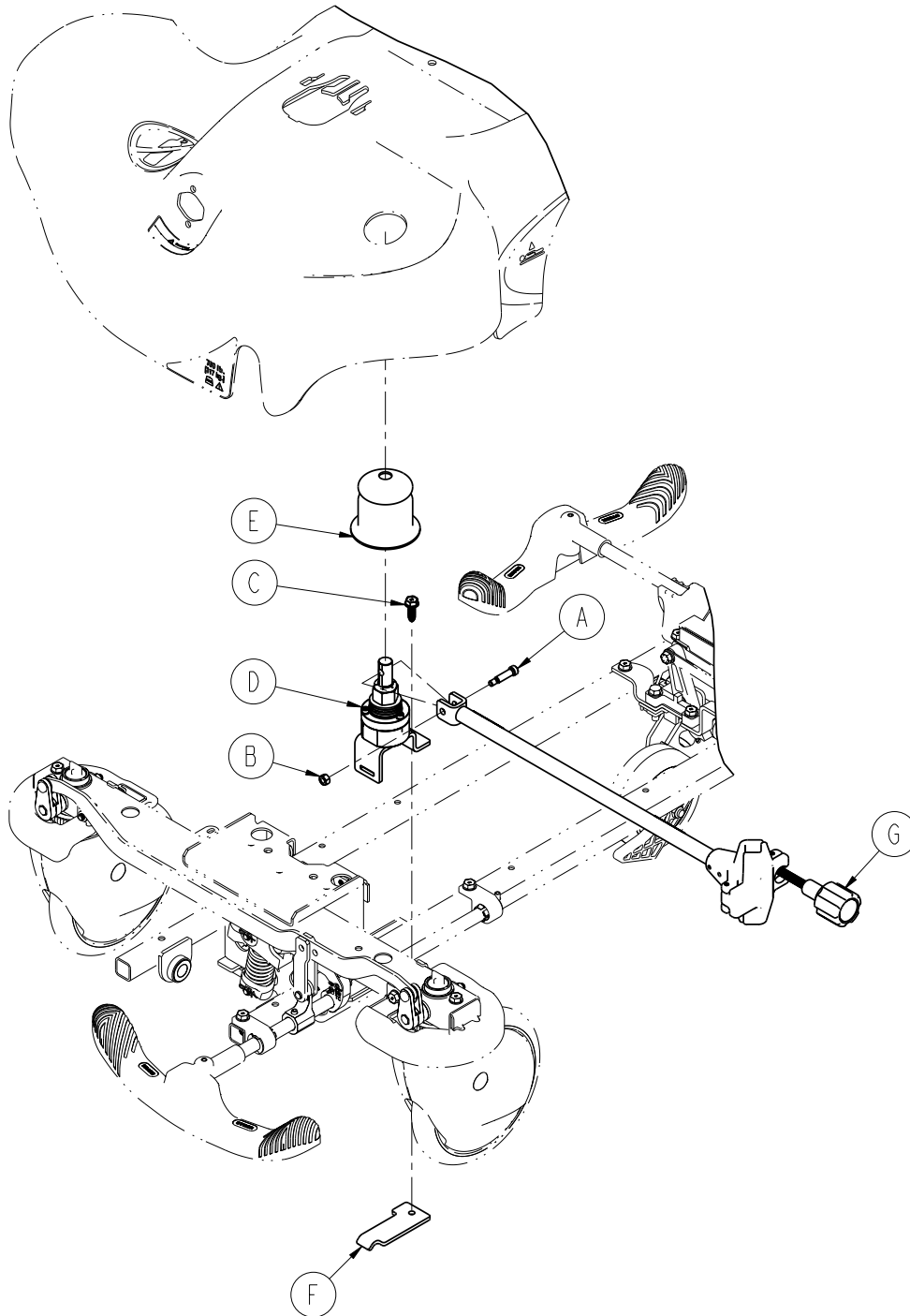

Item	Part No.	Part Name	Qty.
A	0008-006-000	Socket Head Set Screw	1
B	0016-118-000	Hex Lock Nut	1
C	0023-288-000	Hex Washer Head Screw	1
D	0753-122-001	Clutch Assembly	1
E	0753-122-036	Boot	1
F	0753-122-103	I.V. Caddy Plate	1
G	1050-091-044	Euro Arm Assembly	1
H	1105-024-010	Label, Storage	1

*Requires Installation Toolkit

[Return To Table of Contents](#)

Removable I.V. Pole - 0390-025-000

Rev J

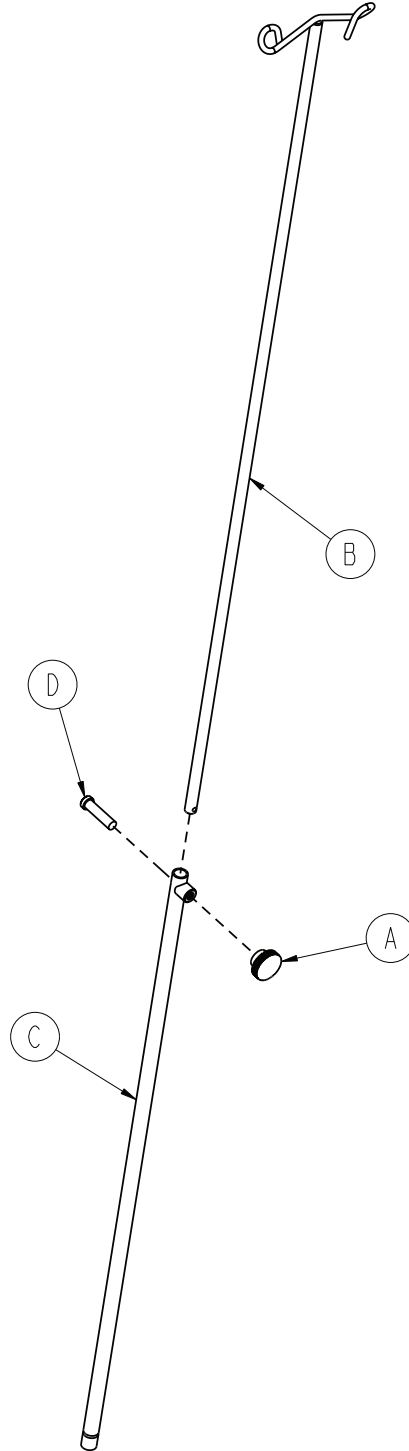

Item	Part No.	Part Name	Qty.
A	0390-003-056	Knob	1
B	0390-003-053	Double I.V. Assembly	1
C	0393-003-043	Chrome Tube Assembly	1
D	0004-496-000	Socket Head Cap Screw	1

Tethered I.V. Pole Assembly - 1001-087-018

Rev D

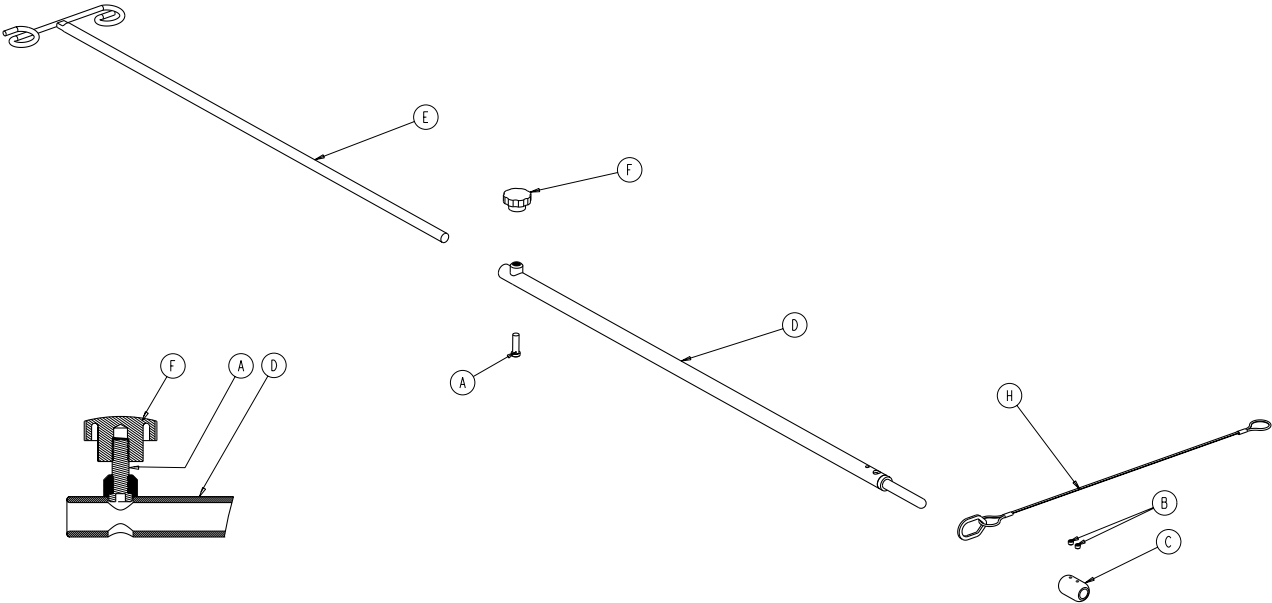

Item	Part No.	Part Name	Qty.
A	0004-495-000	Socket Head Cap Screw	1
B	0021-016-000	Set Screw	2
C	0741-047-014	Retainer	1
D	0938-001-305	Pole Socket Assembly	1
E	0938-001-308	Pole Assembly	1
F	1211-117-016	Plastic Knob	1
H	1211-117-020	Cable Assembly	1

Two-Stage I.V. Pole Assembly, Head End 1010-081-000

Rev E

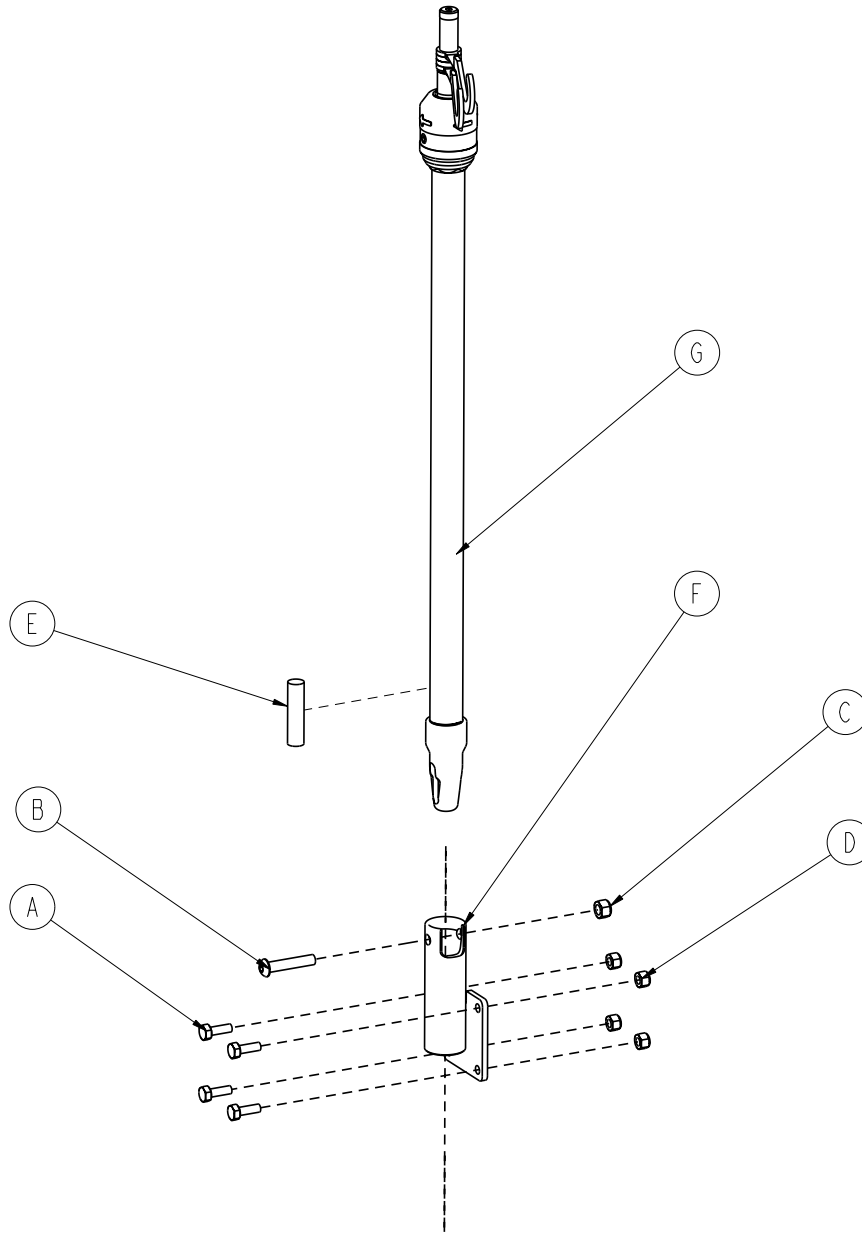

Item	Part No.	Part Name	Qty.
A	0003-050-000	Hex Head Cap Screw	4
B	0004-199-000	Button Head Cap Screw	1
C	0016-036-000	Fiberlock Hex Nut	1
D	0016-028-000	Fiberlock Hex Nut	4
E	1001-059-042	Plug	1
F	1001-259-111	I.V. Pivot Weldment	1
G	1211-210-010	Two-Stage I.V. Pole Assembly	1

Three-Stage I.V. Pole Assembly, Head End 1020-061-000/ Three-Stage I.V. Pole Assembly, Foot End 1020-062-000

Rev D

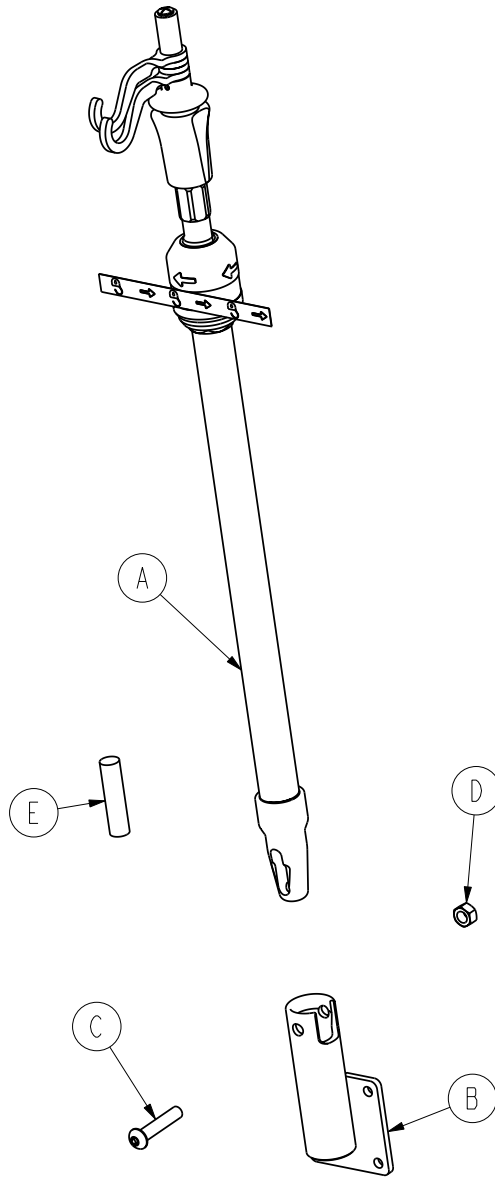

Item	Part No.	Part Name	Qty.
A	1211-211-010	Three-Stage I.V. Pole Assembly	1
B	1001-259-111	I.V. Pivot Weldment	1
C	0004-091-000	Button Head Cap Screw	1
D	0016-020-000	Centerlock Nut	1
E	1001-159-042	Plug	1

[Return To Table of Contents](#)

Two-Stage I.V. Pole Assembly, Foot End 1010-080-000

Rev F

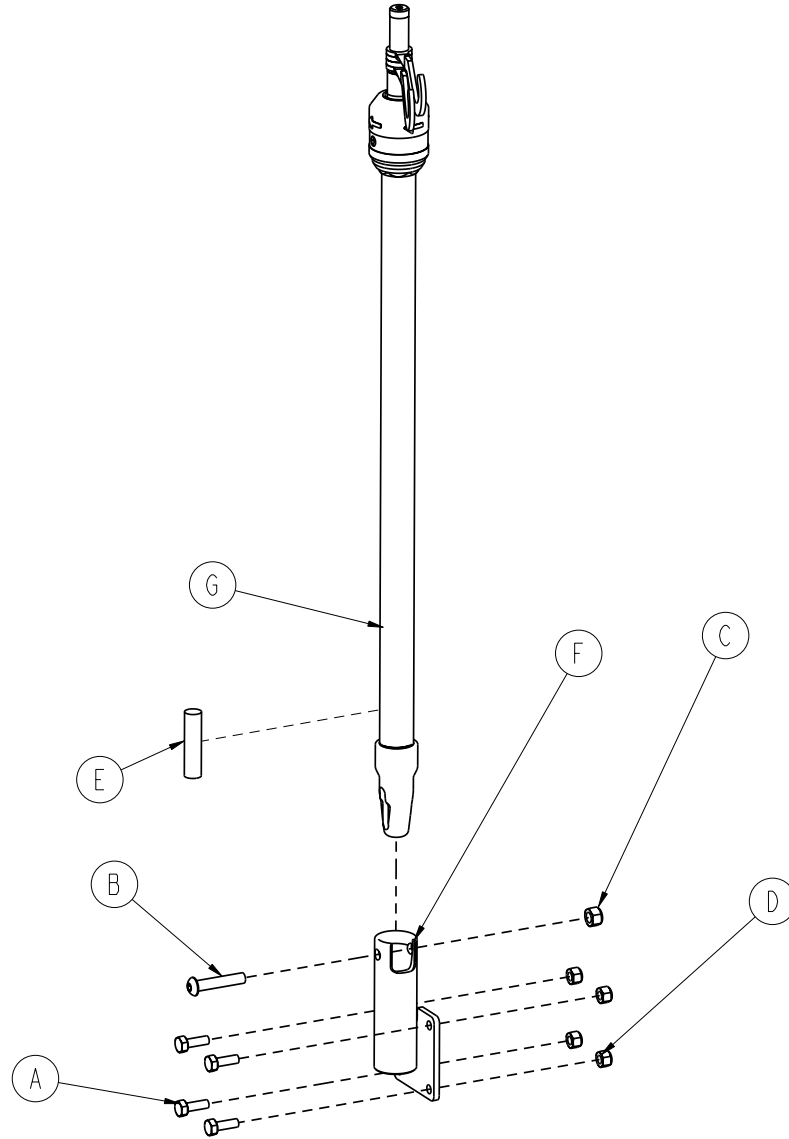

Item	Part No.	Part Name	Qty.
A	0003-050-000	Hex Head Cap Screw	4
B	0004-199-000	Button Head Cap Screw	1
C	0016-036-000	Fiberlock Hex Nut	1
D	0016-028-000	Fiberlock Hex Nut	4
E	1001-059-042	Plug	1
F	1001-259-111	I.V. Pivot Weldment	1
G	1211-210-010	Two-Stage I.V. Pole Assembly	1

Upright Oxygen Bottle Holder - 1115-130-000

Rev A

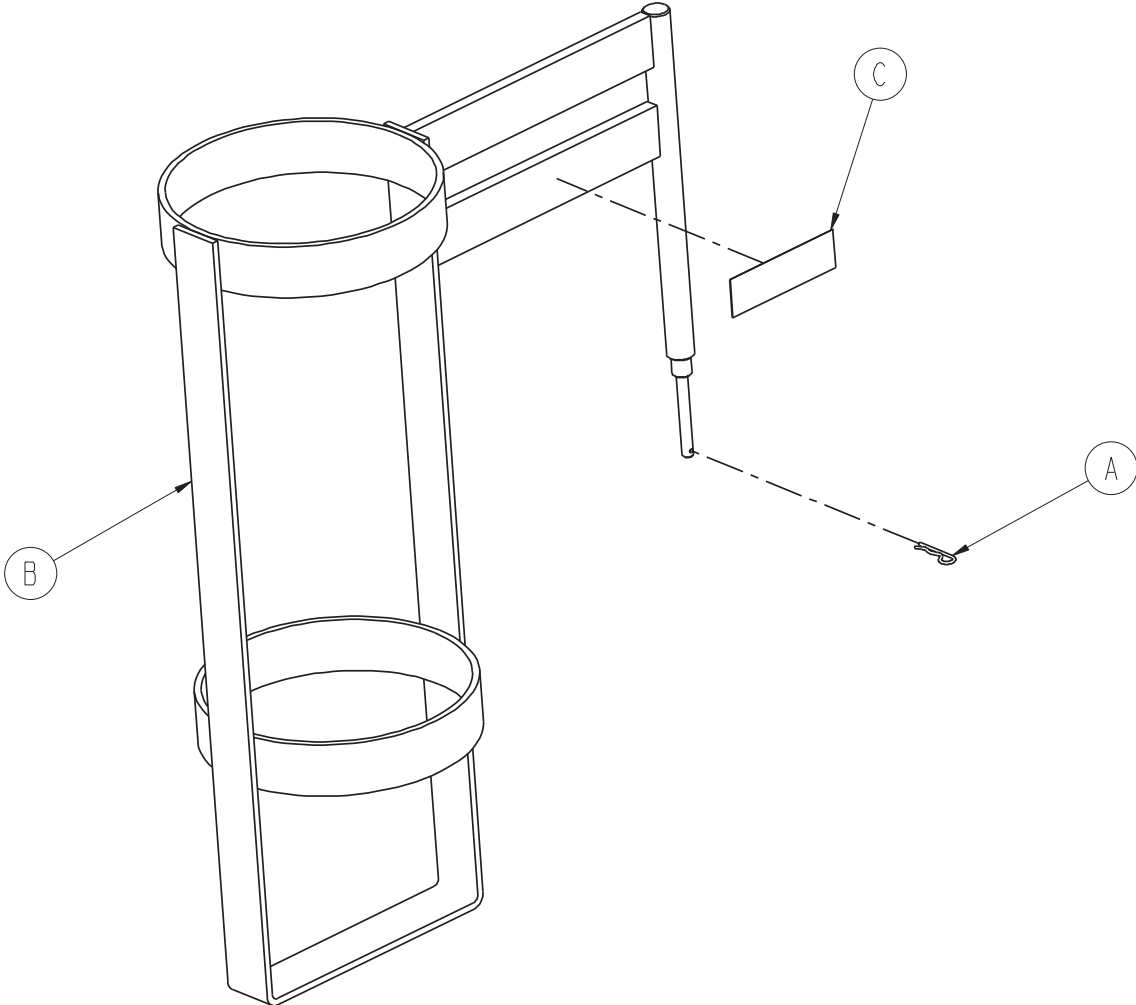

Item	Part No.	Part Name	Qty.
A	0027-030-000	Hair Pin Cotter	1
B	1115-030-111	Upright Bottle Holder	1
C	0747-030-117	Label, Oxygen Bottle Holder	1

Serving Tray - 1105-045-700

Rev A

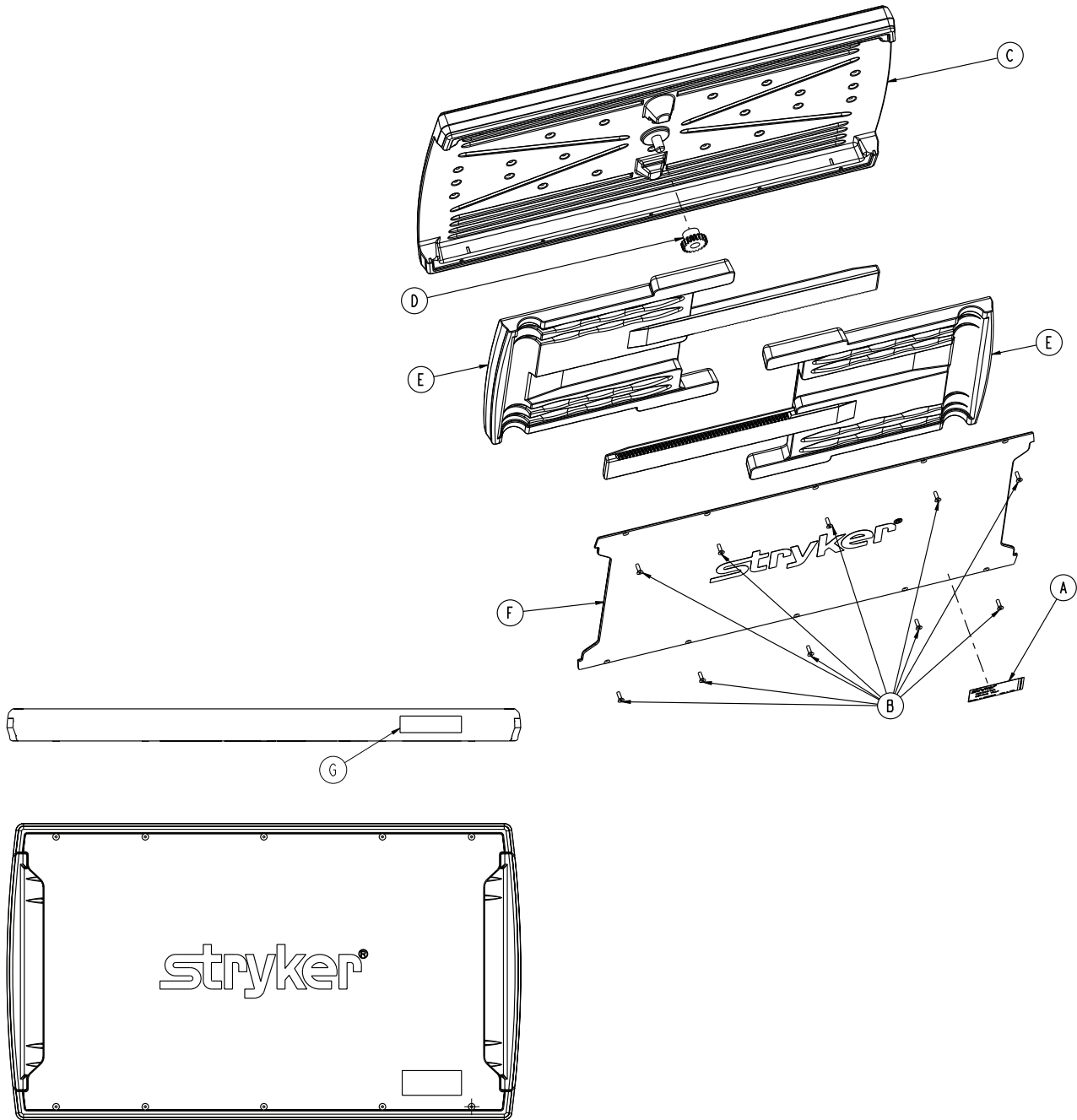

Item	Part No.	Part Name	Qty.
A	1105-045-701	Label, Serving Tray	1
B	0785-045-704	Flat Head Torx Screw	10
C	1105-045-705	Serving Tray Top	1
D	0785-045-706	Serving Tray Pinion	1
E	1105-045-710	Serving Tray Slider	2
F	1105-045-715	Serving Tray Cover	1
G	1105-045-403	Label, Weight Capacity	1

Foot Board/Serving Tray Holder - 1105-045-800

Rev A

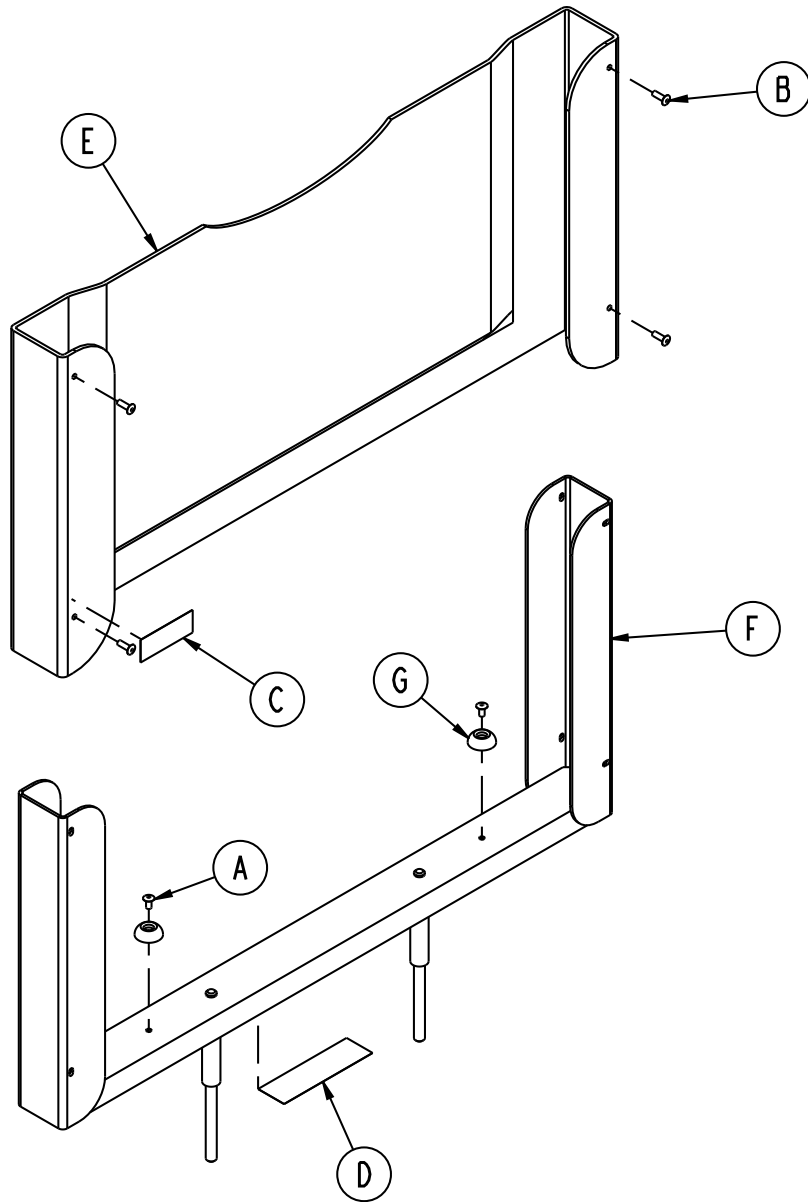

Item	Part No.	Part Name	Qty.
A	0025-079-000	Rivet	2
B	0025-133-000	Rivet	4
C	1105-045-402	Label, Push/Pull	1
D	1105-045-801	Label, Serving Tray Holder	1
E	1105-045-805	Footboard	1
F	1105-045-810	Footboard Support Weldment	1
G	0946-001-155	Bumper	2

[Return To Table of Contents](#)

Mattresses and Siderail Pads

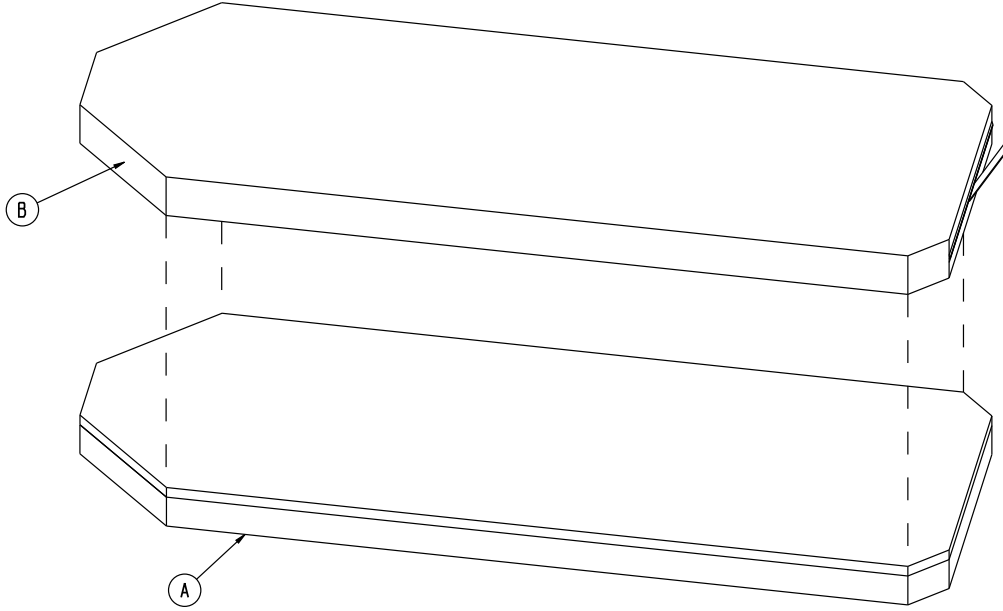

Mattress, 2" Thick x 26" Wide, Standard.....	1059-226-001
Mattress, 3" Thick x 26" Wide, Standard.....	1059-326-001
Mattress, 4" Thick x 26" Wide, Ultra Comfort.....	0785-034-603
Mattress, 5" Thick x 26" Wide, Ultra Comfort.....	0785-034-633
Mattress, 5" Thick x 26" Wide, Pioneer.....	0850-026-000

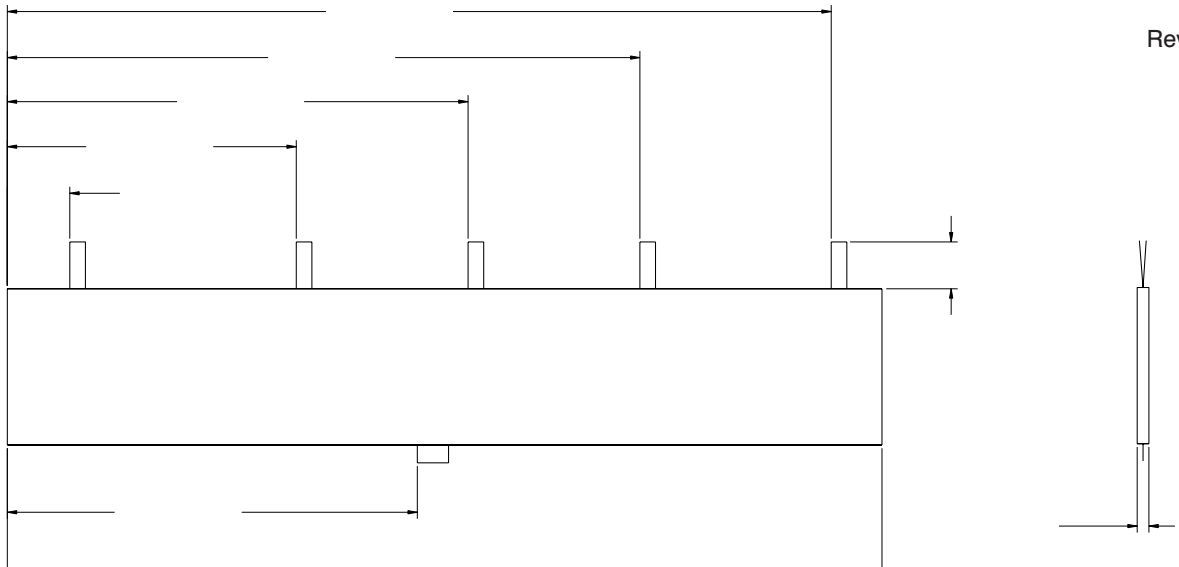

Siderail Pad Set.....	1010-052-000
-----------------------	--------------

Warranty

LIMITED WARRANTY

Stryker Medical Division, a division of Stryker Corporation, warrants to the original purchaser of the Stryker Model 1037 Trauma Stretcher to be free from defects in material and workmanship for a period of one (1) year after date of delivery. Stryker's obligation under this warranty is expressly limited to supplying replacement parts and labor for, or replacing, at its option, any product which is, in the sole discretion of Stryker, found to be defective. If requested by Stryker, products or parts for which a warranty claim is made shall be returned prepaid to the factory. Any improper use or any alteration or repair by others in such manner as in Stryker's judgment affects the product materially and adversely shall void this warranty. Any repair of Stryker products using parts not provided or authorized by Stryker shall void this warranty. No employee or representative of Stryker is authorized to change this warranty in any way.

Stryker Medical Stretcher products are designed for a 10 year expected service life under normal use, conditions, and with appropriate periodic maintenance as described in the maintenance manual for each device. Stryker warrants to the original purchaser that the welds on its Stretcher products will be free from structural defects for the expected 10 year life of the Stretcher product as long as the original purchaser owns the product.

This statement constitutes Stryker's entire warranty with respect to the aforesaid equipment. **Stryker makes no other warranty or representation, either expressed or implied, except as set forth herein. There is no warranty of merchantability and there are no warranties of fitness for any particular purpose. In no event shall Stryker be liable here under for incidental or consequential damages arising from or in any manner related to sales or use of any such equipment.**

Warranty does not include any disposable items, I.V. poles (except for Stryker permanently attached poles), mattresses, batteries, or damage resulting from abuse.

TO OBTAIN PARTS AND SERVICE

Stryker products are supported by a nationwide network of dedicated Stryker Field Service Representatives. These representatives are factory trained, available locally, and carry a substantial spare parts inventory to minimize repair time. Simply call your local representative, or call Stryker Customer Service USA at 1-800-327-0770.

SERVICE CONTRACT COVERAGE

Stryker has developed a comprehensive program of service contract options designed to keep your equipment operating at peak performance at the same time it eliminates unexpected costs. We recommend that these programs be activated before the expiration of the new product warranty to eliminate the potential of additional equipment upgrade charges.

A Service Contract helps to:

- Ensure equipment reliability
- Stabilize maintenance budgets
- Diminish downtime
- Establish documentation for JCAHO
- Increase product life
- Enhance trade-in value
- Address risk management and safety

Warranty

SERVICE CONTRACT PROGRAMS

Stryker offers the following service contract programs:

Service Agreement Options	Premium	Complete	Standard *
Annually scheduled preventative maintenance	X		X
All parts**, labor, and travel	X	X	
Unlimited emergency service calls	X	X	
Priority one contact: two hour phone response	X	X	
Most repairs will be completed within 3 business days	X	X	
JCAHO documentation	X	X	X
On-site record of PM & emergency service	X		X
Factory-trained Stryker service technician	X	X	X
Stryker authorized parts used	X	X	X
Service during regular business hours (8-5)	X	X	X

* Replacement parts and labor for products under PM contract will be discounted.

** Does not include any disposable items, I.V. poles (except for Stryker permanently attached poles), mattresses, batteries, or damage resulting from abuse.

Stryker Medical also offers personalized service contracts.
Pricing is determined by age, location, model and condition of product.

**For more information on our service contracts,
please call your local representative.**

RETURN AUTHORIZATION

Merchandise cannot be returned without approval from the Stryker Customer Service Department. An authorization number will be provided which must be printed on the returned merchandise. Stryker reserves the right to charge shipping and restocking fees on returned items. **Special, modified, or discontinued, items not subject to return.**

DAMAGED MERCHANDISE

ICC Regulations require that claims for damaged merchandise must be made with the carrier within fifteen (15) days of receipt of merchandise. **Do not accept damaged shipments unless such damage is noted on the delivery receipt at the time of receipt.** Upon prompt notification, Stryker will file a freight claim with the appropriate carrier for damages incurred. Claim will be limited in amount to the actual replacement cost. In the event that this information is not received by Stryker within the fifteen (15) day period following the delivery of the merchandise, or the damage was not noted on the delivery receipt at the time of receipt, the customer will be responsible for payment of the original invoice in full. Claims for any short shipment must be made within thirty (30) days of invoice.

INTERNATIONAL WARRANTY CLAUSE

This warranty reflects U.S. domestic policy. Warranty outside the U.S. may vary by country. Please contact your local Stryker Medical representative for additional information.



United States

Stryker Medical
3800 E. Centre Ave.,
Portage, Michigan USA
49002

EC	REP
-----------	------------

European Representative

Stryker France
ZAC Satolas Green Pusignan
Av. De Satolas Green
69881 MEYZIEU Cedex
France



stryker[®]